

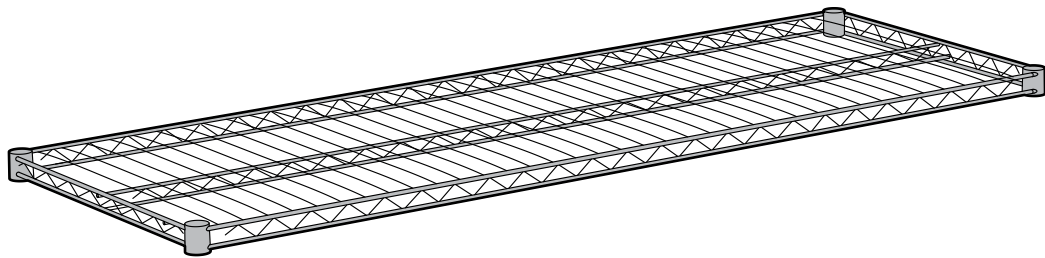

Create amazing spaces™

Overhead Rack

User manual | *Mode d'emploi* | **Manual del usuario** | *Montageanleitung* | **Montagehandleiding** | *Manuale per l'utente* | **Manual do utilizador**



50 Kg
110 Lb



For Stronghold / Summit / Alpine only:



8x8



8x6



10x8

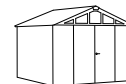

10x11.5



10x15

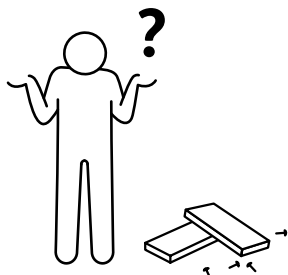

WWW.KETER.COM

US / Canada: (EN/FR)

Tel: +1-888-374-4262

keter.com/en-us/contact-us.html

Email: NACS@keter.com

UK

Tel: +44-121-506-0008





CSUK@keter.com

For other European countries see the last page

Pour les autres pays d'Europe, voir la dernière page

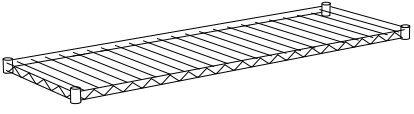
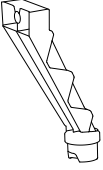
Para otros países europeos vea la última página

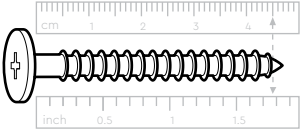
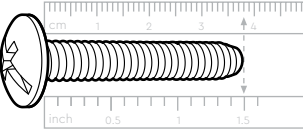
ASSEMBLY PARTS | PIÈCES À ASSEMBLER | MONTAGETEILE | MONTAGESTUKKEN | PIEZAS DE ENSAMBLE | PARTI DA MONTARE | PEÇAS DE MONTAGE

 <p>53.3 x 152.4 cm 21"x 60"</p> <p>LSN (x1)</p>	 <p>LSA (x4)</p>	 <p>LSC (x4)</p>	
 <p>LSU (x4)</p>	 <p>s45b (x4) 45 mm / 1.77"</p>	 <p>sc38 (x4) 38mm / 1.49"</p>	 <p>scn8 (x4)</p>

Packaging may contain some additional small parts for use as spare parts | L'emballage peut contenir de petites pièces supplémentaires à utiliser comme pièces de rechange | El envoltorio puede contener algunas piezas pequeñas adicionales que se pueden utilizar como repuestos | In der Verpackung können kleine Zusatztteile enthalten sein, die als Ersatzteile genutzt werden können | De verpakking kan een aantal kleine extra onderdelen bevatten, die als reserveonderdeel gebruikt kunnen worden | L'imballo potrebbe contenere piccoli componenti supplementari da utilizzare come ricambistica | A embalagem pode conter algumas pequenas peças adicionais para utilização como peças de reposição

REQUIRED TOOLS | OUTILS EXIGÉS | HERRAMIENTAS NECESARIAS | BENÖTIGTE WERKZEUGE | BENODIGD GEREEDSCHAP | ATTREZZATURA OCCORRENTE | FERRAMENTAS NECESSÁRIAS

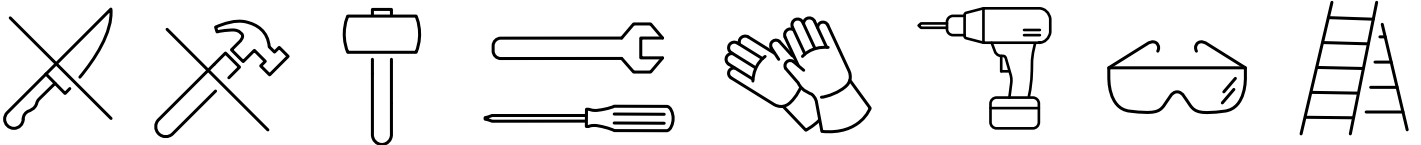

**PLACE THE OVERHEAD RACK IN ANY OF THE AVAILABLE POSITIONS | ALLEZ À L'ÉTAPE POUR LA TAILLE DE VOTRE ABRI
| GEHEN SIE ZUM SCHRITT FÜR IHRE SCHUPPENGROSSE | GA NAAR DE STAP VOOR UW SCHUURMAAT | IR AL PASO
PARA EL TAMAÑO DE SU COBERTIZO | VAI AL PASSO PER LA DIMENSIONE DEL TUO CAPANNO | VÁ PARA O PASSO
PARA O TAMANHO DO SEU ABRIGO**

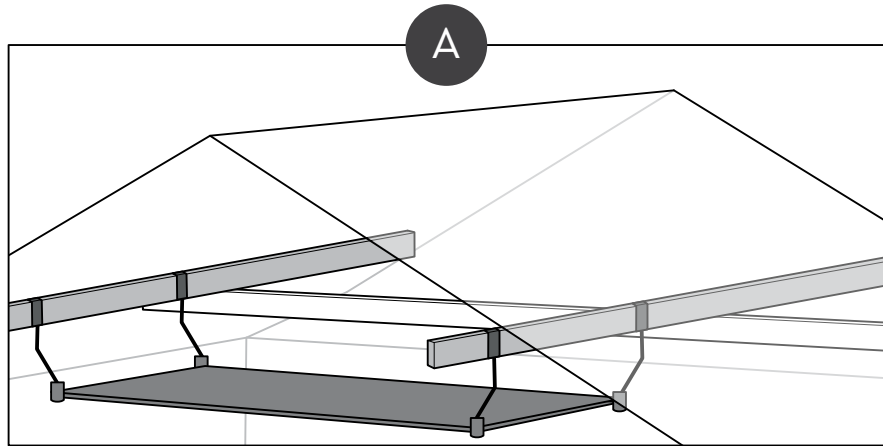

OR

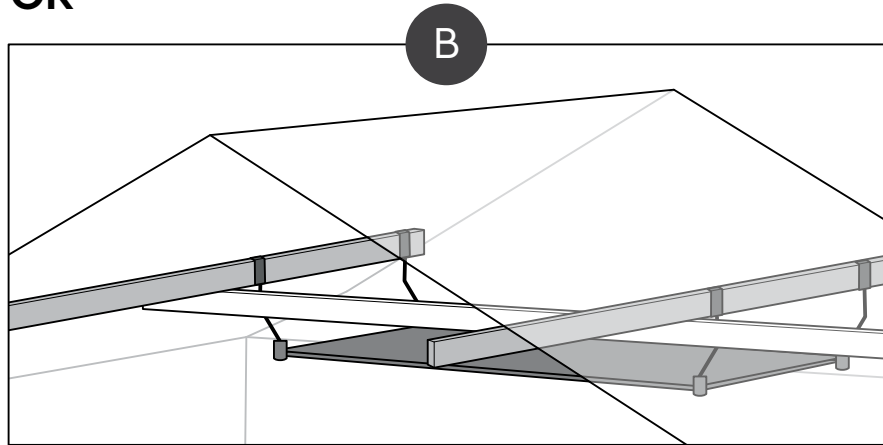

OR

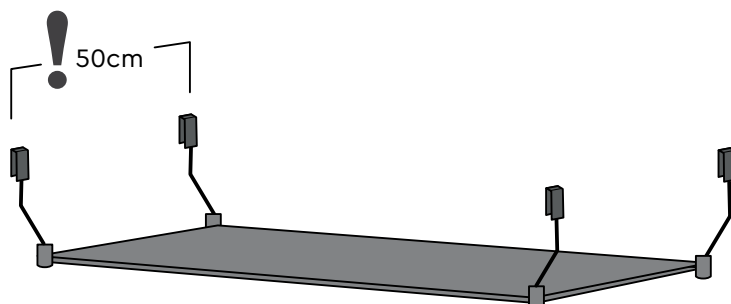
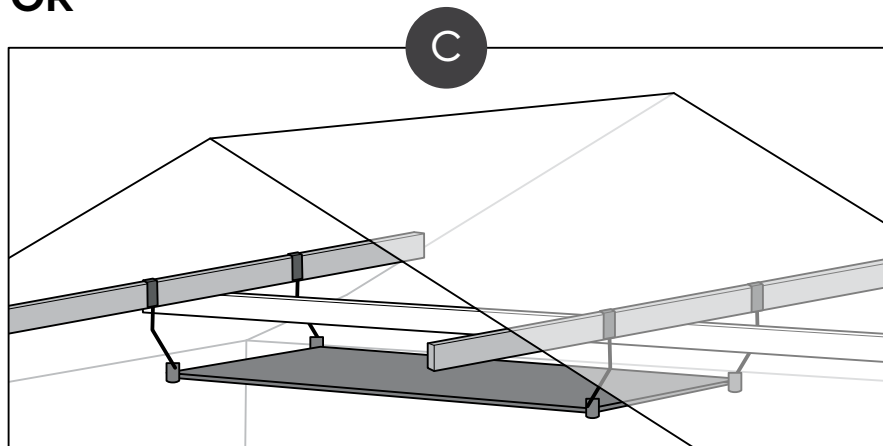

1



LSU (x4)

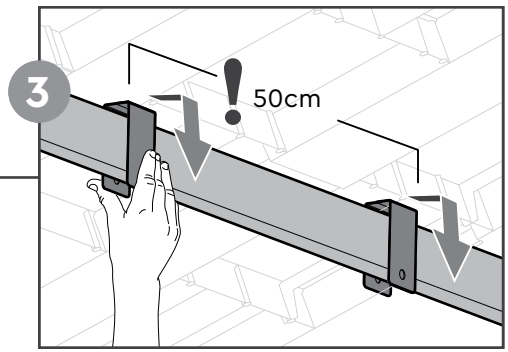
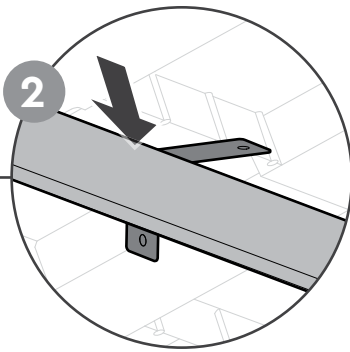
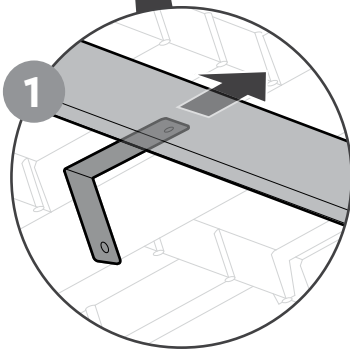
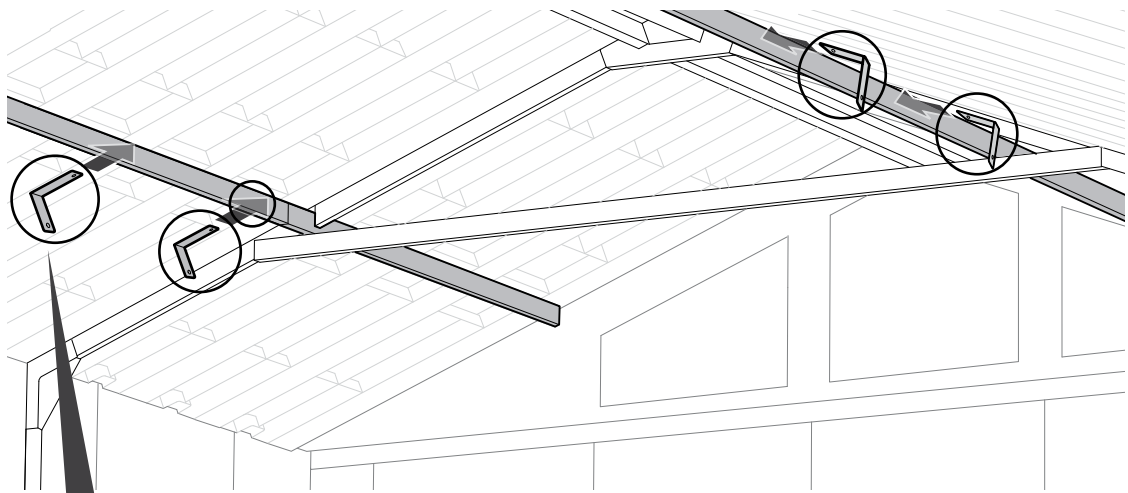

IDENTIFY YOUR SHED SIZE AND FOLLOW THE INSTRUCTIONS FOR YOUR CONFIGURATION. | ALLEZ À L'ÉTAPE POUR LA TAILLE DE VOTRE ABRI | **GEHEN SIE ZUM SCHRITT FÜR IHRE SCHUPPENGROSSE** | GA NAAR DE STAP VOOR UW SCHUURMAAT | **IR AL PASO PARA EL TAMAÑO DE SU COBERTIZO** | VAI AL PASSO PER LA DIMENSIONE DEL TUO CAPANNO | **VÁ PARA O PASSO PARA O TAMANHO DO SEU ABRIGO**

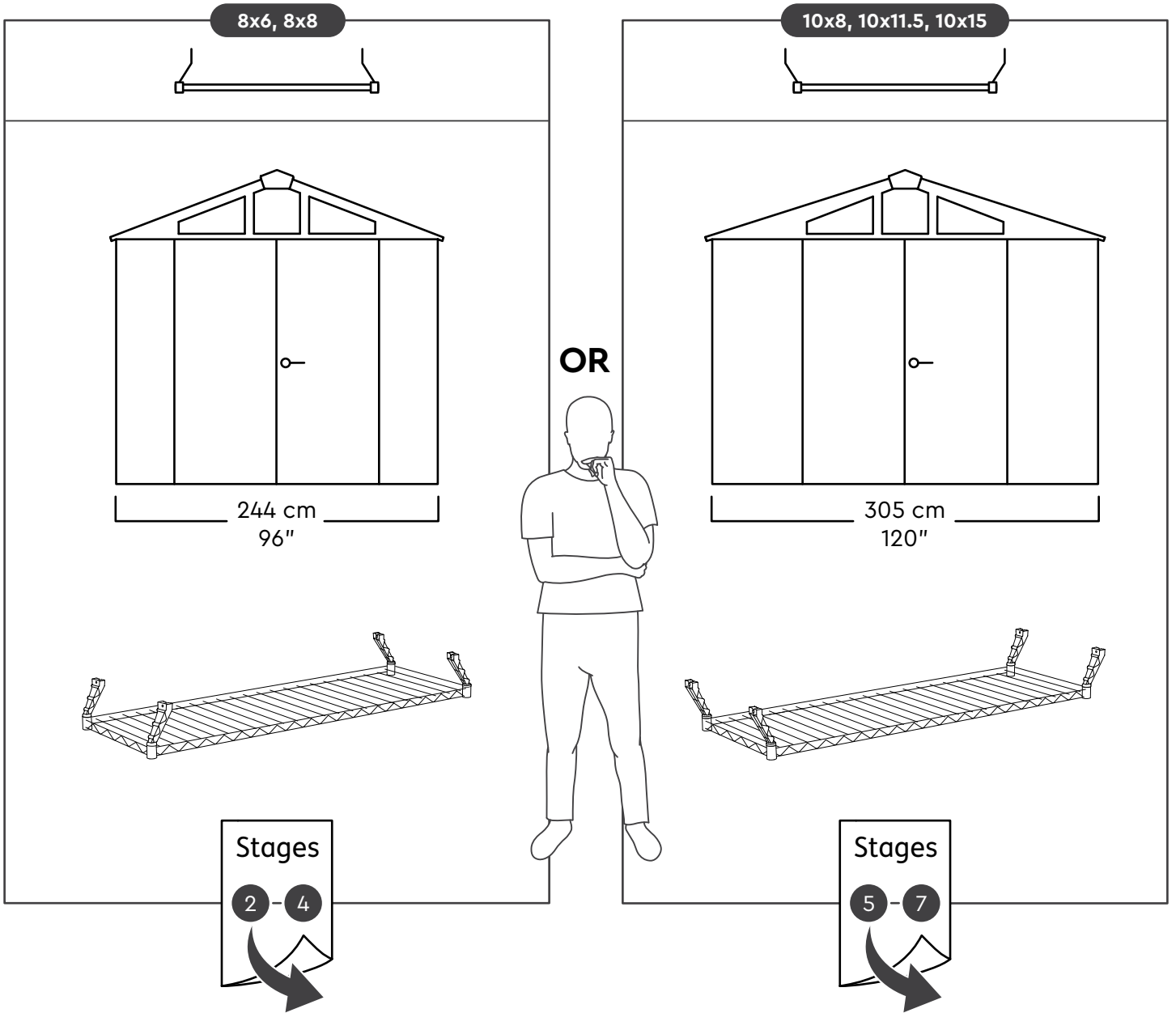

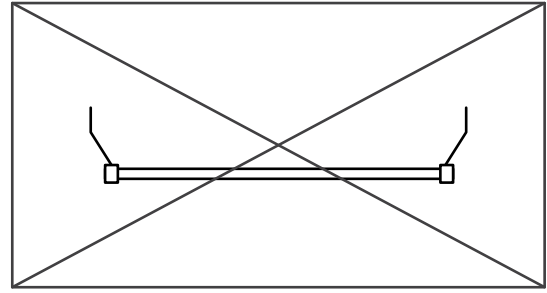
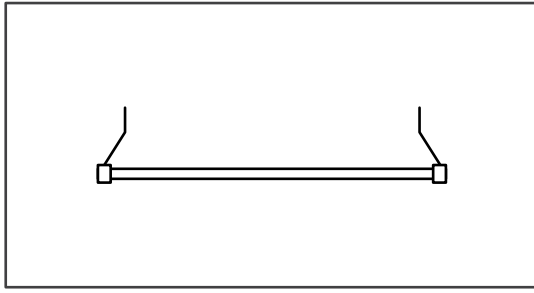

2



LSN (x1)



LSA (x4)



LSC (x4)



s45b (x4)

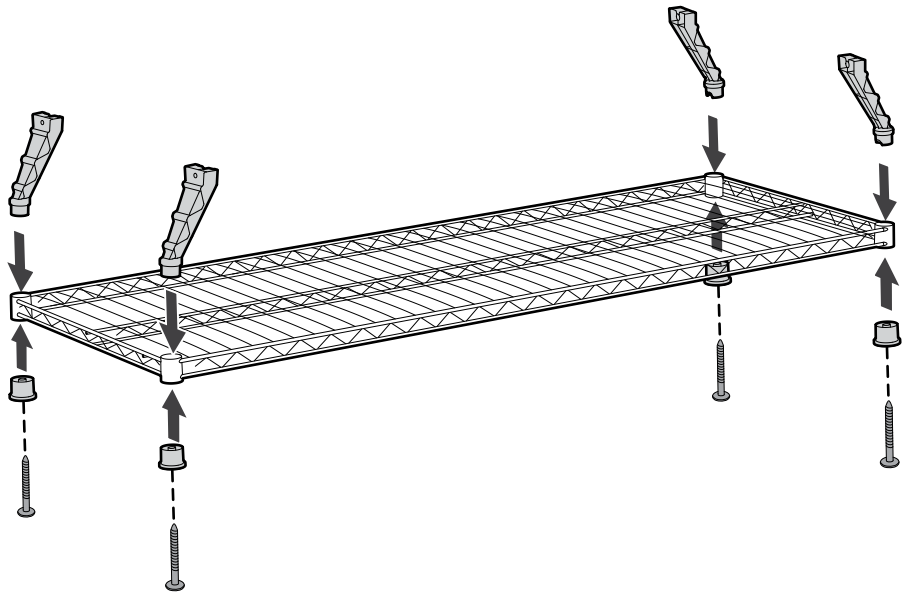
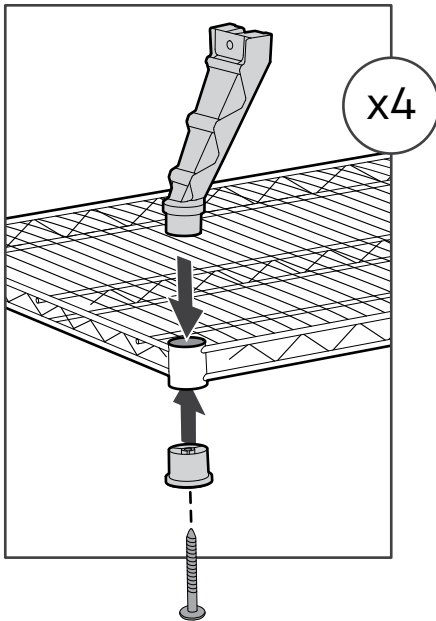
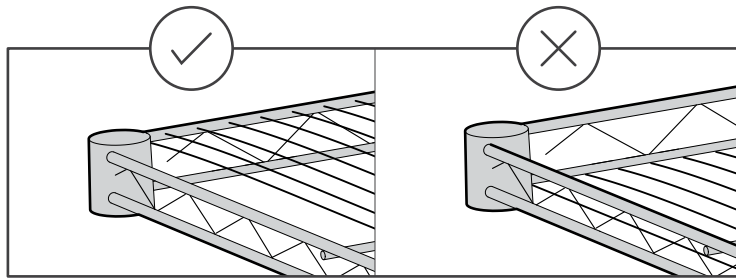

3

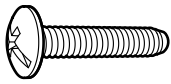

sc38 (x4)

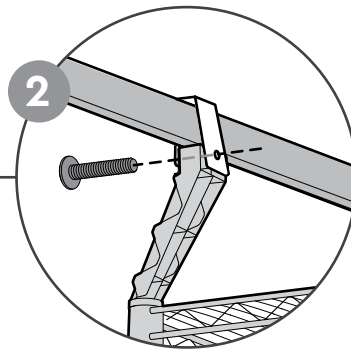
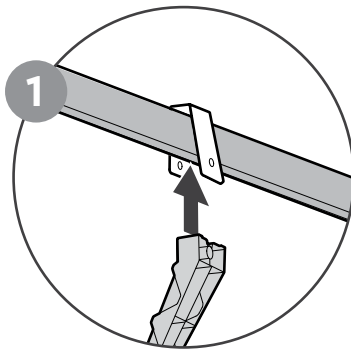
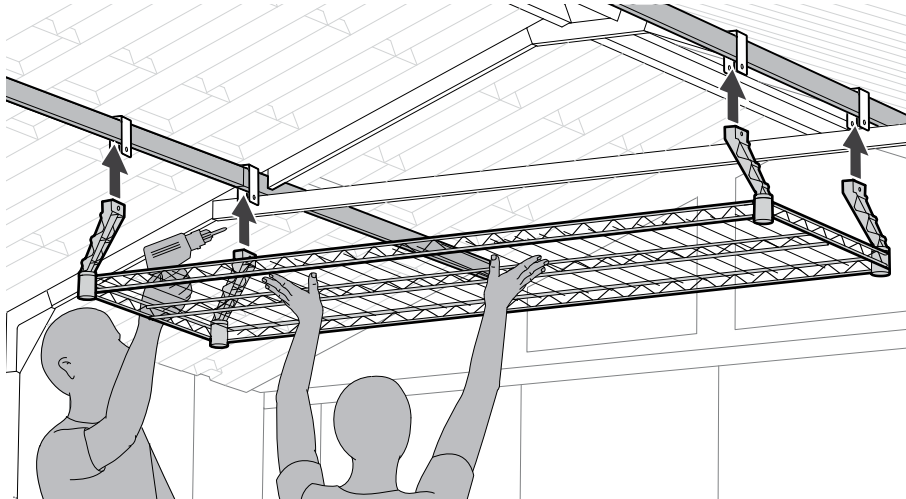

4



scn8 (x4)

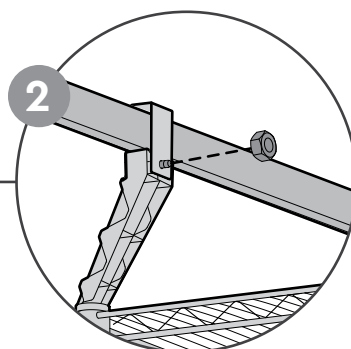
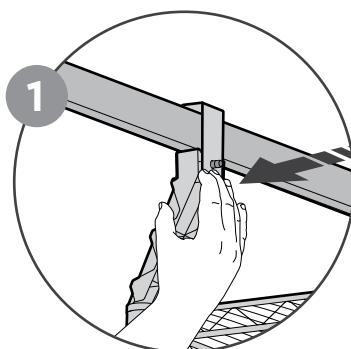
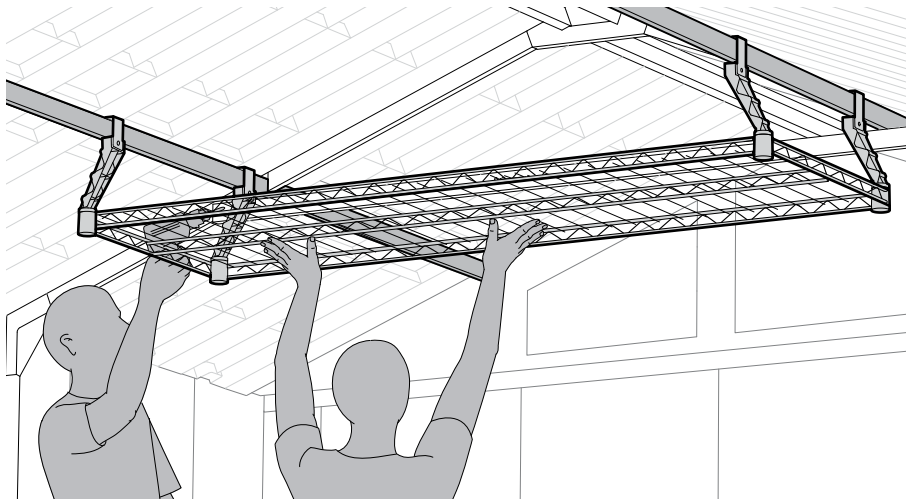

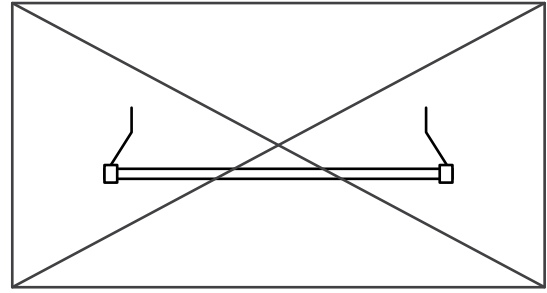
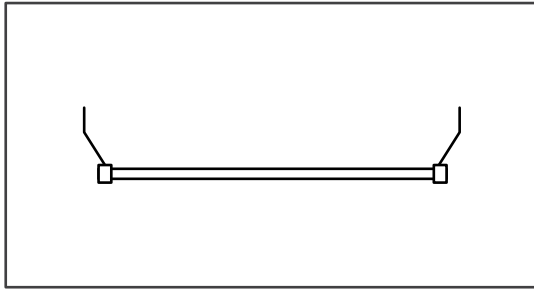

5



LsN (x1)



LSA (x4)



LsC (x4)



s45b (x4)

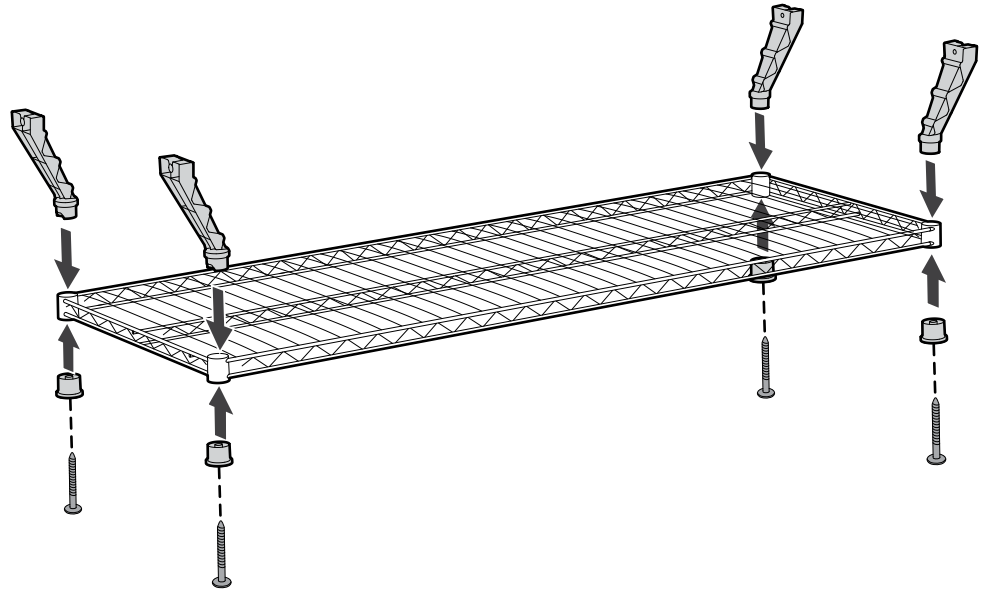
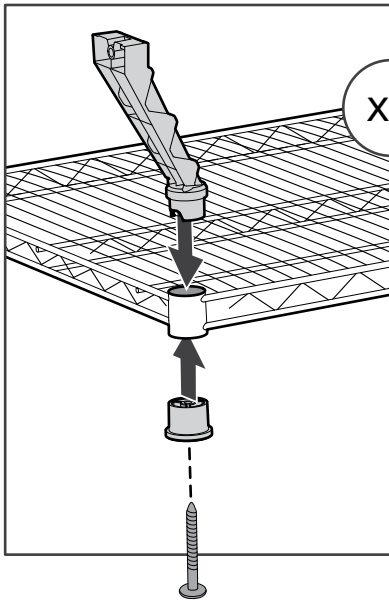
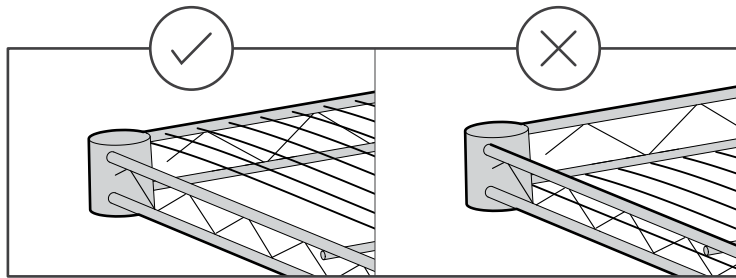

6

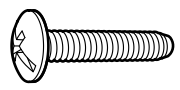

sc38 (x4)

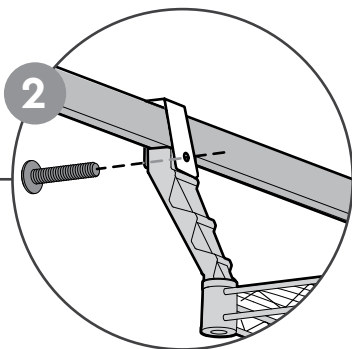
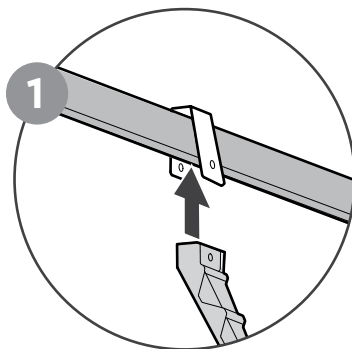
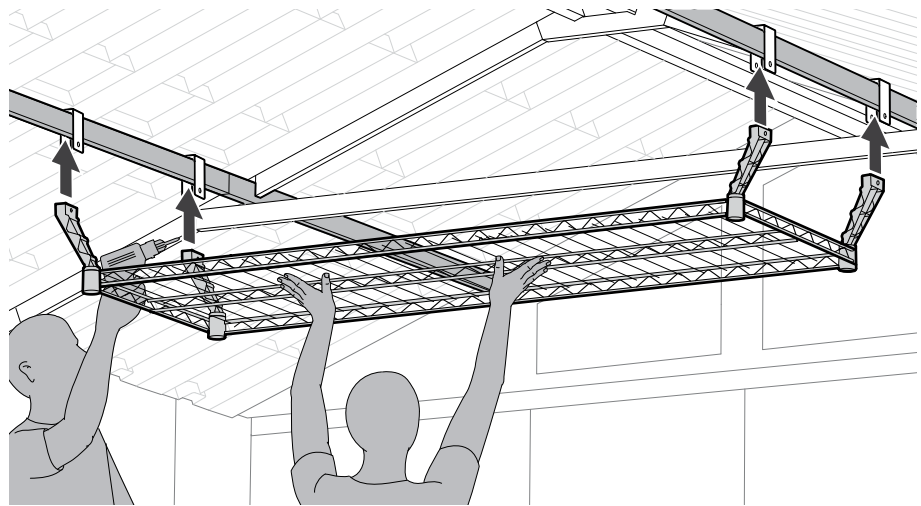

7



scn8 (x4)

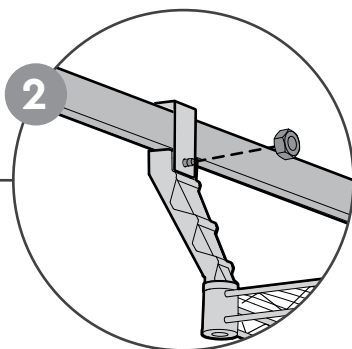
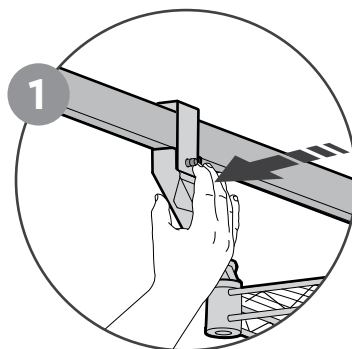
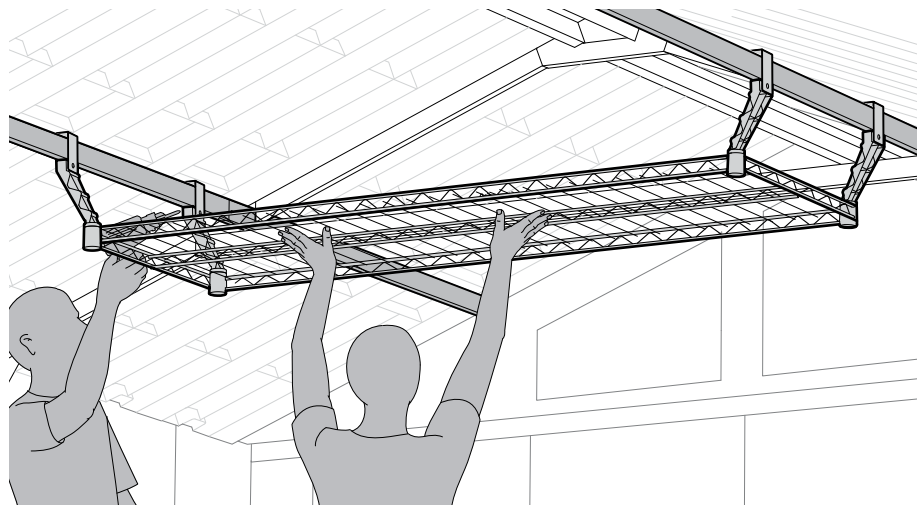

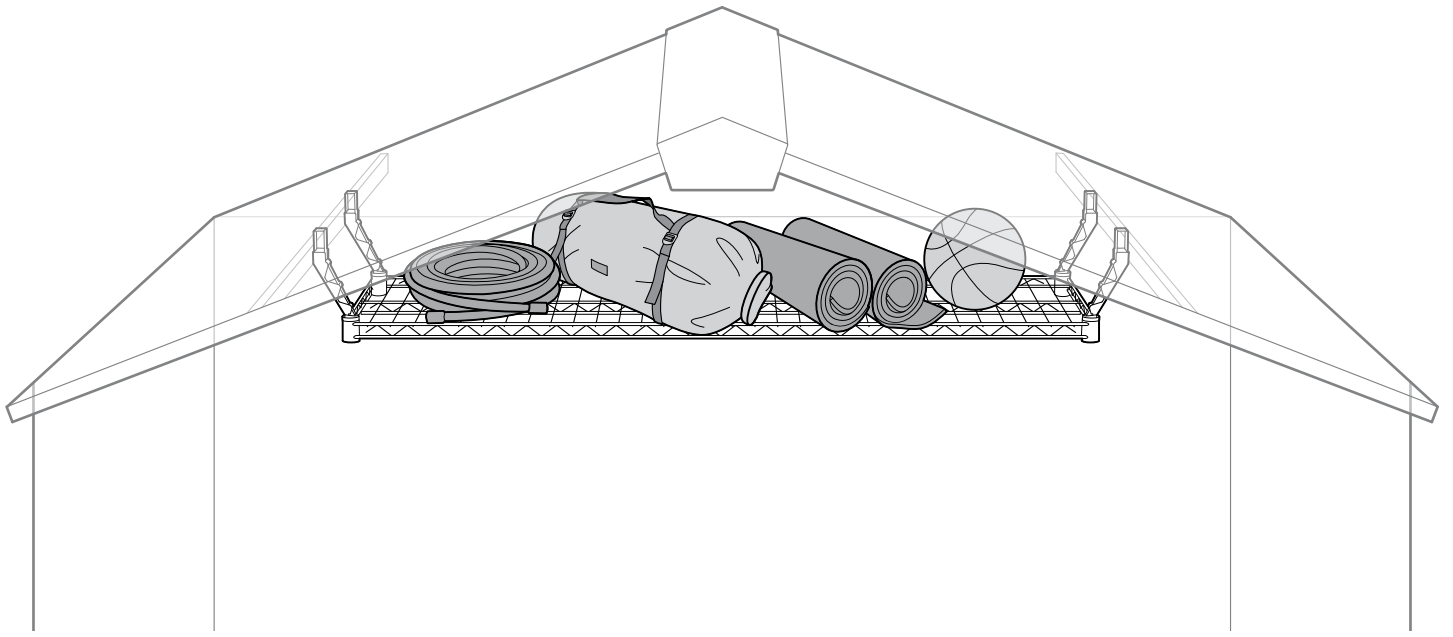

2-YEAR LIMITED WARRANTY

Your Loft ("the Product") was manufactured from high-quality materials under rigorous control and supervision. Should a problem occur with the Product, please address your claim to Keter customer service on our website (www.keter.com) or by phone. This warranty covers product failure resulting from defects in manufacturing or materials for a period of 2 years from the date of original retail purchase. (The term "defects" is defined as imperfections that impair the use of the Product). This warranty does not cover defects resulting from normal wear and tear, including, but not limited to, scuffing, scratches or fractures caused during use, discoloration or fading, rusting, unreasonable use, abuse, negligence, alterations, painting, moving, transporting or relocating the Product, "acts of Nature," including, but not limited to, hail, any type of storm, flood and fire, and consequential or incidental damages. Assembly and handling of the Keter Shed and/or the Product not in accordance with the recommendations, guidelines and restrictions as described in the Product's user manual and/or in the Keter Shed's manual, and usage for commercial or public applications, will void this warranty. Upon submitting proof of purchase and evidence of the claimed product failure, and subject to reporting the failure in a timely manner, Keter, at its sole discretion, will replace defective parts of the Product, or refund you a prorated portion of the purchase price on a straight line depreciated basis for the length of the warranty.

GARANTIE LIMITÉE DE 2 ANS

Votre Porte vélos (le « Produit ») a été fabriqué à partir de matériaux de haute qualité et a fait l'objet d'une rigoureuse procédure de contrôle et de supervision. Si un problème survient avec le Produit, veuillez adresser vos réclamations au service client de Keter, sur le site Web : www.keter.com, ou via téléphone. Cette garantie couvre les défaillances du Produit résultant de défauts de fabrication ou du matériau durant une période de 2 ans, à compter de la date d'achat en boutique. (Le terme « défauts » doit être interprété de la manière suivante : imperfections pouvant nuire à l'utilisation du produit). Cette garantie ne couvre pas les défauts résultants de l'usure normale comme, sans pour autant s'y limiter, tout type d'éraflures, de rayures ou de fractures durant l'utilisation, la décoloration ou le pâlissement, la rouille, découlant d'un usage déraisonnable, d'abus, de négligence, de toute modification, peinture, déplacement, transport ou déménagement du produit, de tout phénomène naturel comme, sans pour autant s'y limiter, la grêle, tout type de tempête, d'inondation, d'incendie ou tout autre dégât indirect ou accessoire. Tout assemblage ou manipulation d'une étagère Keter et/ou du Produit non conforme aux recommandations, directives et restrictions décrites dans le manuel d'utilisation du Produit et/ou dans le manuel d'étagère Keter, et le mode d'utilisation commerciale ou publique recommandé annuleront la présente garantie. Sur présentation d'une preuve d'achat et d'une preuve de la défaillance du Produit, et sous réserve de signaler ladite défaillance en temps voulu, Keter pourra, à sa seule discrétion, remplacer les pièces défectueuses du Produit ou vous rembourser une partie proportionnelle du prix d'achat sur une base d'amortissement linéaire pour la durée de la garantie.

GARANTÍA LIMITADA DE 2 AÑOS

Este Porta bicicletas (el «Producto») ha sido fabricado con materiales de alta calidad bajo riguroso control y supervisión. Si el Producto llega a presentar un problema, dirija su queja a servicio al cliente de Keter visitando nuestro sitio web (www.keter.com) o llamando por teléfono. Esta garantía cubre las fallas del Producto que se produzcan debido a defectos en la fabricación o materiales durante un periodo de 2 años a partir de la fecha original de compra minorista. (El término «Defecto» se define como las imperfecciones que impiden el uso del Producto). Esta garantía no cubre defectos resultantes del desgaste y uso normal, entre otros, los rayones, fracturas o rasguños sufridos durante su uso; decoloración, desvanecimiento, oxidación, uso irracional, abuso, negligencia, alteraciones, pintura, movimiento, transporte o relocalización del Producto; «fenómenos naturales», entre otros, granizo, cualquier tipo de tormenta, inundación o incendio; y daños consecuentes o incidentales. No ensamblar y manipular el cobertizo Keter y/o el Producto conforme a las recomendaciones, directrices y restricciones que se describen en el manual del usuario y/o en el manual del cobertizo Keter, y su uso para aplicaciones comerciales o públicas, anulará esta garantía. Luego de presentar el comprobante de compra y evidencia de la supuesta falla del producto, y sujeto a que el reporte de esta se haga dentro del periodo de tiempo oportuno, Keter, a su entera discreción, reemplazará las piezas defectuosas del Producto o le reembolsará una porción del precio (prorateada mediante el método de línea recta) durante la vigencia de la garantía.

AUF 2 JAHRE BEGRENZTE GEWÄHRLEISTUNG

Ihr Wandhalterung für Fahrräder ("das Produkt") wurde aus hochwertigen Materialien unter strenger Kontrolle und Aufsicht hergestellt. Sollte an dem Produkt ein Problem auftreten, tragen Sie Ihr Anliegen bitte dem Keter-Kundendienst auf unserer Website (www.keter.com) oder über Telefon mit. Diese Garantie deckt Produktausfälle aufgrund von Herstellungs- oder Materialfehlern für einen Zeitraum von 2 Jahren ab dem Datum des ursprünglicher Kaufs im Einzelhandel. (Der Ausdruck "Mängel" wird definiert als Unvollkommenheiten, welche die Verwendung des Produkts behindern). Diese Garantie deckt keine Fehler ab, die von normaler Abnutzung herrühren, einschließlich, aber nicht beschränkt auf Schrammen, Kratzer oder Brüche, Verfärbung oder Verblassen, Rost, unsachgemäße Verwendung, Missbrauch, Fahrlässigkeit, Änderungen, Anstrich, Versatz, Transport oder Umlagerung des Produkts und "Höhere Gewalt", einschließlich, aber nicht darauf beschränkt, Hagel, alle Arten von Stürmen, Überflutung und Feuer und Folgeschäden oder zufällige Schäden. Der Zusammenbau und die Handhabung des Keter-Schuppens und/oder des Produkts, die nicht den Empfehlungen, den Richtlinien und Einschränkungen, wie in der Gebrauchsanleitung des Produkts oder im Handbuch des Keter-Schuppens beschrieben, entsprechen, sowie die Verwendung für kommerzielle oder öffentliche Anwendungen lassen diese Garantie erlöschen. Nach Vorlage des Kaufbelegs und Nachweis des beanstandeten Produktfehlers und unter der Voraussetzung, dass der Fehler rechtzeitig gemeldet wird, wird Keter nach eigenem Ermessen die fehlerhaften Teile des Produkts ersetzen oder Ihnen einen Anteil des Kaufpreises auf einer direkten linearen Abschreibungsbasis für die gesamte Laufzeit der Garantie gemäß den Keter-Richtlinien zurückerstatten.

2-JAAR BEPERKTE GARANTIE

Uw Fietsrek ("het product") wordt gefabriceerd van materiaal van hoge kwaliteit en onder een rigoureuze controle en toezicht. Mocht er een probleem optreden met het product, dien dan uw claim in bij de klantenservice van Keter via onze website (www.keter.com) of per telefoon. Deze garantie dekt uitsluitend van het product veroorzaakt door fabricatedefecten of het materiaal voor een periode van 2 jaar vanaf de datum dat het in de winkel werd gekocht. (De term "defecten" wordt gedefinieerd als onvolkomenheden die het gebruik van het Product belemmeren). Deze garantie dekt geen defecten die het gevolg zijn van normale slijtage, waaronder maar niet beperkt tot, wrijving, krassen of barsten veroorzaakt door gebruik, verkleuring of verbleking, roest, onredelijk gebruik, misbruik, verwaarlozing, wijzigingen, verven of het verplaatsen, transporteren of verhuizen van het Product, en natuurrampen, waaronder, maar niet beperkt tot hagel, allerlei soorten stormen, overstromingen en brand en gevolgschade of incidentele schade. Het niet assembleren en hanteren van de Keter berging en/of het Product in overeenstemming met de aanbevelingen, gebruiksaanwijzing en beperkingen zoals beschreven in de handleiding van het Product en/of de Keter berging en het gebruik ervan voor commerciële of openbare toepassing zullen deze garantie ongeldig maken. Bij het overhandigen van de originele aankoopbon en bewijs van de geclaimde uitsluitend van het product, en onderhevig aan het onmiddellijk rapporteren van de ontdekking ervan, kan Keter, geheel naar eigen inzicht, de defecte onderdelen van het Product vervangen of u een evenredig deel van de aankoop prijs vergoeden op basis van een lineaire afschrijving voor de lengte van de garantie.

2 ANNI DI GARANZIA LIMITATA

Il vostro Gancio porta biciclette ("il Prodotto") è stato fabbricato con materiali di alta qualità sotto un controllo e una supervisione rigorosi. In caso di problemi con il Prodotto, rivolgersi al servizio clienti Keter sul nostro sito web (www.keter.com) o per telefono. Questa garanzia copre i guasti del prodotto derivanti da difetti di fabbricazione o dei materiali per un periodo di 2 anni dalla data di acquisto. (Il termine "difetti" è definito come imperfezioni che compromettono l'uso del Prodotto). La presente garanzia non copre i difetti derivanti dalla normale usura, inclusi, a titolo esemplificativo e non esaustivo, graffi, scalfitture o rotture causate dall'uso, scolorimento o sbiadimento, arrugginimento, uso irragionevole, abuso, negligenza, alterazioni, verniciatura, spostamento, trasporto o ricollocazione del Prodotto, "cause di forza maggiore", inclusi, a titolo esemplificativo e non esaustivo, grandine, qualsiasi tipo di tempesta, inondazione e incendio, e danni conseguenti o accidentali. L'assemblaggio e la manipolazione della Keter Shed e/o del prodotto non in conformità con le raccomandazioni, le linee guida e le restrizioni descritte nel manuale d'uso del prodotto e/o nel manuale della Keter Shed e l'uso per applicazioni commerciali o pubbliche renderanno nulla la presente garanzia. Dietro presentazione della prova d'acquisto e della prova del presunto guasto del prodotto, e a condizione che il guasto venga segnalato tempestivamente, Keter, a sua esclusiva discrezione, sostituirà le parti difettose del Prodotto o rimborserà al cliente una parte proporzionale del prezzo d'acquisto su una base di ammortamento lineare per la durata della garanzia.

GARANZIA LIMITADA DE 2 ANOS

Seu Porta bicicletas ("o Produto") foi fabricada com materiais de alta qualidade sob rigoroso controle e supervisão. Caso ocorra um problema com o Produto, por favor dirija sua reclamação ao atendimento ao cliente da Keter em nosso site (www.keter.com) ou por telefone. Esta garantia cobre falhas no produto resultante de defeitos no material ou na fabricação por um período de 2 anos a partir da data original da compra. (O termo "defeitos" se refere a imperfeições que prejudicam o uso do produto). Esta garantia não cobre defeitos resultantes do desgaste normal, incluindo, mas não limitado a, ranhuras, arranhões ou fraturas causadas durante o uso, descoloração ou desbotamento, ferrugem, uso irracional, abuso, negligência, alterações, pintura, movimentação, transporte ou realocação do Produto, "atos da natureza", incluindo, entre outros, granizo, qualquer tipo de tempestade, inundação e incêndio e danos consequentes ou acidentais. A montagem e manuseamento do Keter Shed e/ou do Produto em desacordo com as recomendações, orientações e restrições descritas no manual do utilizador do Produto e/ou no manual do Keter Shed e a utilização para fins comerciais ou públicos anulam esta garantia. Ao enviar o comprovante de compra e a evidência da falha alegada do produto e reportar a falha em tempo hábil, a Keter, a seu exclusivo critério, substituirá as peças defeituosas do Produto ou reembolsará a você uma parte proporcional do preço de compra em um base de depreciação linear em relação a duração da garantia.

If there are missing or broken parts, please do not return the product to the store.
Please access our website www.keter.com, or contact customer service at your country/region:

S'il y a des pièces manquantes ou cassées, ne retournez pas le produit au magasin.
Veuillez accéder à notre site web www.keter.com ou contacter le service client de votre pays/région:

Si hubiera alguna parte faltante o dañada, no devuelva el producto a la tienda.
Acceda a nuestra web www.keter.com o contacto con el servicio de atención al cliente de su país/región:

Bitte bringen sie ihr produkt nicht gleich zum laden zurück, falls teile fehlen oder defekt sind.
Bitte loggen sie in unsere website ein oder wenden sie sich an unseren kundenservice:

In geval van ontbrekende of beschadigde onderdelen kunt u gebruik maken van de keter onderdelenservice.
Ga naar onze website www.keter.com of neem contact op met de klantenservice via onderstaande contactgegevens:

In caso di parti mancanti o rotte, preghiamo di no restituire il prodotto al negozio.
Chiediamo cortesemente di accedere al nostro sito web www.keter.com o, contattare il servizio clienti del vostro paese:

Se existirem peças danificadas ou partidas por favor não efectuar devolução à loja.
Aceda ao nosso site www.keter.com ou ao nosso serviço de pós venda:

US / Canada: (EN/FR)

Tel: +1-888-374-4262
keter.com/en-us/contact-us.html
Email: NACS@keter.com

UK: (EN)

Tel: +44-121-506-0008
Email: CSUK@keter.com
Keter UK Ltd
16 Great Queen Street, Covent
Garden, London, WC2B 5AH
Mon - Fri | 8am - 4pm

Israel:

Tel: 1-700-70-6015

Switzerland:

Tel: +41-62-767-00-50
Email: info@neogard.ch

France:

Votre produit ayant été acheté dans une enseigne, qu'elle soit physique ou sur internet, c'est auprès de cette enseigne que vous devez faire votre demande SAV.

Australia:

Tel: 03 9544 6999
Email: info@ketergroup.com.au
28 Buckland St,
Clayton, Victoria 3168
Mon - Fri | 9am - 5pm

Iberia:

Email: spvketer@carcaba.com

South Africa:

Email: info@keter.co.za
<https://za.keter.com/>

Spain: (SP)

Tel: +34-876-14-13-93
www.keter.com/es-es/contact-us.html
E-mail: Service.Iberia@keter.com
Mon - Fri | 8am - 5pm

Italy:

Tel: +39 0422 745900
Email: Servizio.clienti@keter.com

고객센터:

Tel: 031-767-2492
Email: info@keter.co.kr
월 - 금 | 9:00am - 05:30pm

Poland:

Tel: +48 59 84 19 892
Email: Service.poland@keter.com

Hungary:

Tel: +36 52 565 900
Email: Service.hungary@keter.com

Nordics:

Tel: +48 59 84 19 892
Email: Service.nordic@keter.com

Germany/Austria:

Tel: +49 (3) 222-10-96-42-1
Email: service@keter-ersatzteile.de

NL/BE/LUX:

Email: service.benelux@keter.com

WWW.KETER.COM

