

**KETER**<sup>®</sup>

Create amazing spaces<sup>™</sup>

evotech<sup>™</sup>

# NEWTON PLUS 7511

USER MANUAL | MODE D'EMPLOI | **MANUAL DEL USUARIO** | MONTAGEANLEITUNG |  
MONTAGEHANDLEIDING | MANUALE PER L'UTENTE | **MANUAL DO UTILIZADOR**

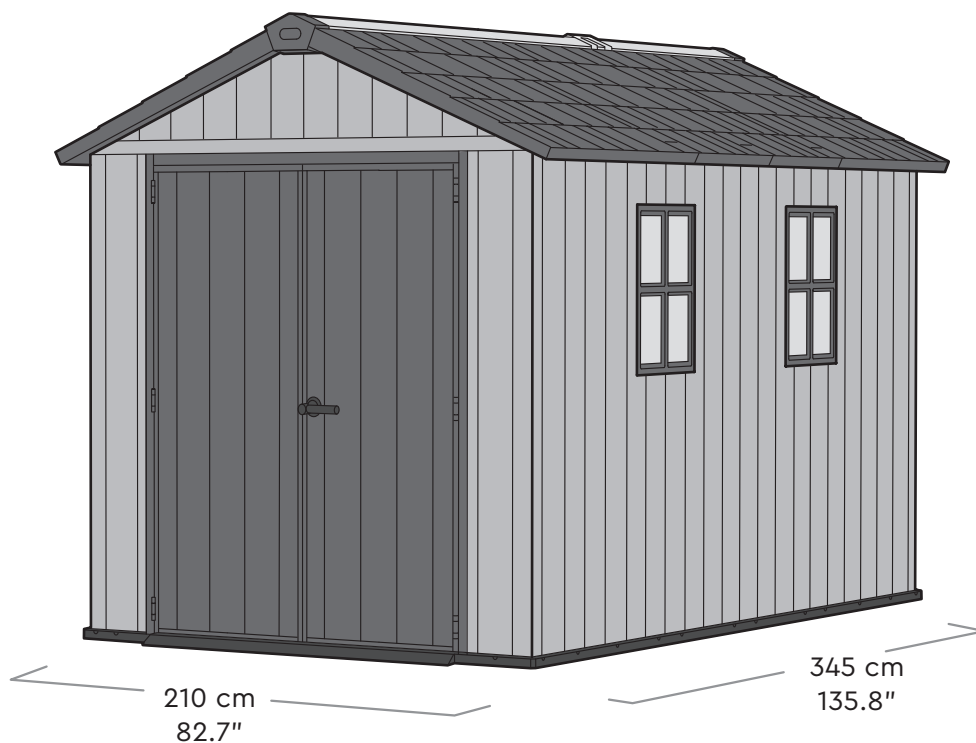

Newton Plus pack A  
Newton Plus pack B  
Newton Plus 4 ft. KIT

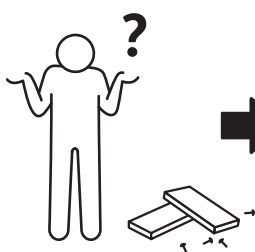

[WWW.KETER.COM](http://WWW.KETER.COM)

**US, Canada: (EN/FR)**

[keter.com/en-us/contact-us.html](http://keter.com/en-us/contact-us.html)

Tel: +1-888-374-4262

Email: [NACS@keter.com](mailto:NACS@keter.com)

**UK**

Tel: +44-121-506-0008, [CSUK@keter.com](mailto:CSUK@keter.com)

Mon - Fri | 8am - 4pm

**For other European countries see the last page**  
Pour les autres pays d'Europe, voir la dernière page  
**Para otros países europeos vea la última página**

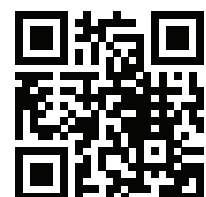

**SITE PREPARATION | PRÉPARATION DU SITE | PREPARACIÓN DEL LUGAR | VORBEREITUNG DES AUFSTELLUNGORTES | VOORBEREIDING VAN HET TERREIN | PREPARAZIONE DEL LUOGO DI ASSEMBLAGGIO | PREPARAÇÃO DO LOCAL**

**Level the ground surface | Nivelez la surface du sol | Nivele la superficie del suelo | Eben Sie die Bodenoberfläche | Maak de ondergrond vlak | Livellare la superficie del terreno | Nivele a superfície do solo**

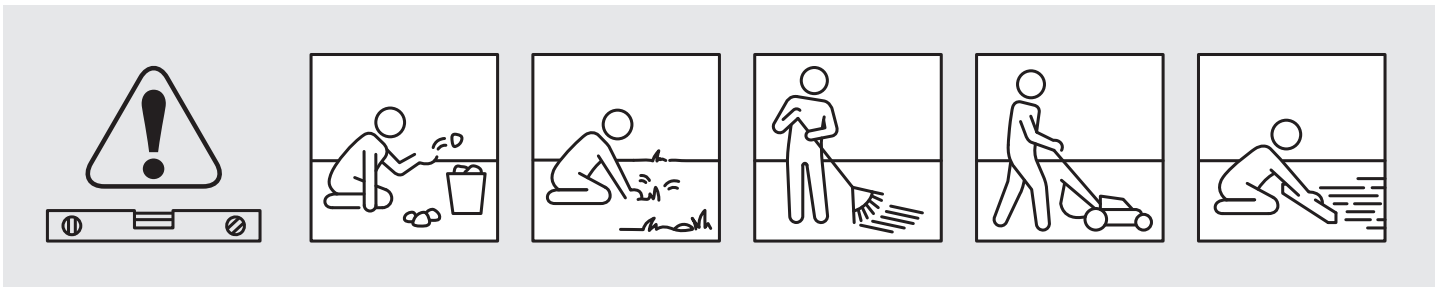

**Recommendation: Construct a wooden or concrete base as a foundation | Recommandation: fabriquez une base en bois ou en béton en guise de fondation | Recomendación: construya una base de madera o de cemento a modo de cimiento | Empfehlung: Bauen Sie als Fundament eine Grundfläche aus Holz oder Beton | Aanbeveling: maak een houten of betonnen ondergrond als fundering | Raccomandazione: Costruire una base di legno o di cemento come fondamenta | Recomendação: Construa uma base de madeira ou de cimento como fundação**

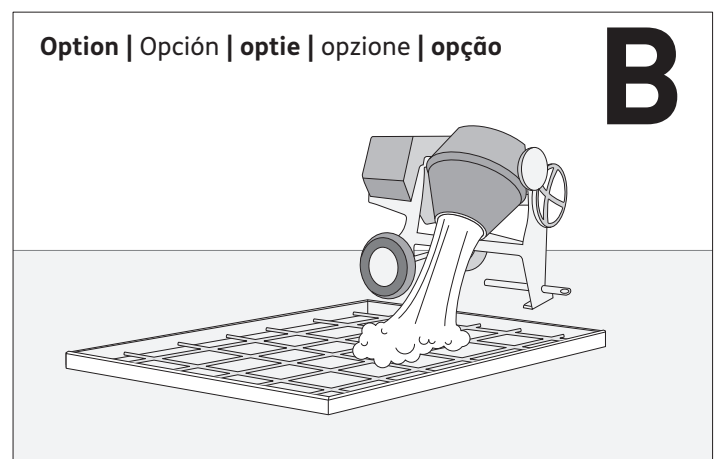
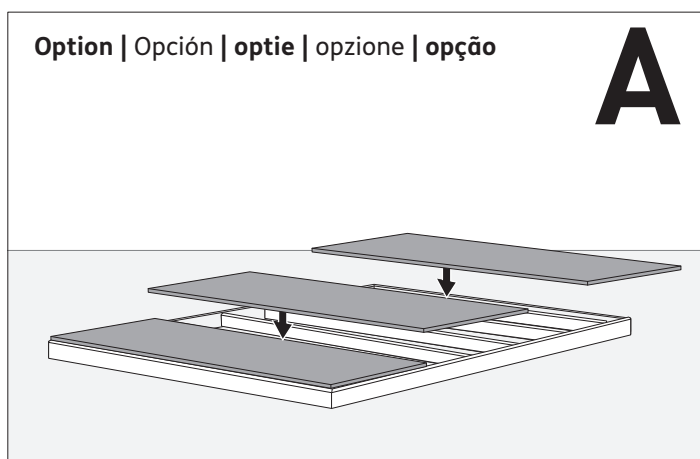

**For external access during assembly, make sure to leave enough room around the outside of the shed assembly site.**

Pour un accès externe au cours du montage, veillez à laisser suffisamment de place autour du site de montage.

**Para tener un acceso exterior durante el montaje, asegúrese de dejar suficiente espacio alrededor del lugar de montaje del cobertizo.**

Lassen Sie am Aufstellungsort außerhalb des Schuppens ausreichend Platz, so dass Sie während des Aufbaus von außen Zugang zum Schuppen haben.

**Om tijdens de montage aan de buitenkant van het schuurtje te kunnen werken, moet u ervoor zorgen dat u genoeg ruimte laat aan de buitenkant van de montageplaats.**

Per accedere alle parti esterne della casetta durante l'assemblaggio, assicurarsi di lasciare abbastanza spazio attorno al luogo di assemblaggio.

**Para ter acesso externo durante a montagem certifique-se de que deixa espaço suficiente em redor do exterior do local de montagem do abrigo.**

**External floor measurements are: | Mesures externes du plancher: | Las medidas del suelo externo son: | Die Außen-Bodenmaße betragen: | De afmetingen van de externe vloer zijn: | Le mesure del pavimento esterno sono: | As medidas externas do chão são:**

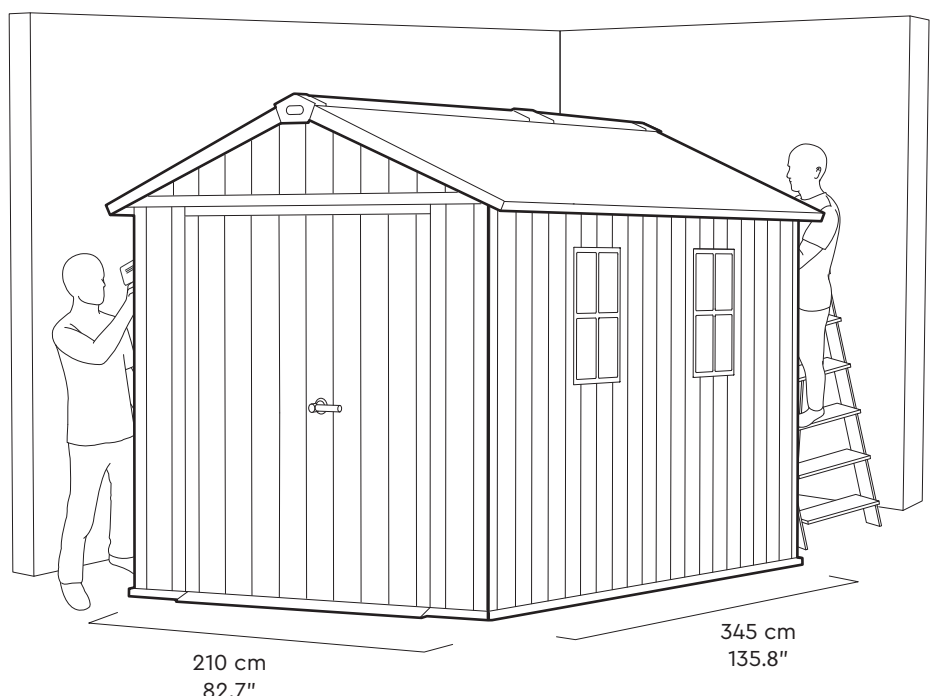

**BEFORE STARTING ASSEMBLY | AVANT DE COMMENCER LE MONTAGE | ANTES DE EMPEZAR EL ARMADO | VOR MONTAGEBEGINN | VOORDAT U BEGINT TE MONTEREN | PRIMA DI INIZIARE L'ASSEMBLAGGIO | ANTES DE INICIAR A MONTAGEM**

**Read the care and safety guidelines at the end of this manual | Check to ensure that there are no missing or damaged parts BEFORE starting or arranging assembly | Remove all parts from the package(s) and spread them out on a clean work surface | Review all assembly instructions | Assemble all the parts according to the directions in this manual. Do not skip any steps.**

Lisez les instructions de précaution et de sécurité à la fin de ce manuel | Assurez-vous qu'il n'y a pas de pièces manquantes ou endommagées AVANT de commencer ou d'organiser l'assemblage | Retirez toutes les pièces du/des paquet(s) et étalez-les sur une surface de travail propre | Lisez toutes les instructions de montage | Assemblez toutes les pièces selon les instructions de ce manuel. Ne sautez aucune étape.

**Lea las instrucciones de precauciones y seguridad que están al final de este manual | Asegúrese de que no faltan piezas ni están dañadas ANTES de comenzar o disponer el montaje | Saque todas las piezas del paquete o paquetes y póngalas sobre una superficie de trabajo limpia | Revise todas las instrucciones de montaje | Monte todas las piezas según las instrucciones de este manual. No se saltee ningún paso.**

Lesen Sie die Sicherheitsrichtlinien am Ende des Benutzerhandbuchs durch | Prüfen Sie bitte VOR dem Zusammenbau, dass keine Teile beschädigt sind oder fehlen | Nehmen Sie alle Teile aus der Verpackung und breiten Sie sie auf einer sauberen Arbeitsfläche aus | Gehen Sie noch einmal die komplette Aufbauanleitung durch | Bauen Sie alle Teile entsprechend der Anleitung in diesem Handbuch zusammen. Lassen Sie dabei keinen Arbeitsschritt aus.

**Lees de richtlijnen over zorg en veiligheid achterin deze handleiding | Controleer of er geen onderdelen ontbreken of beschadigd zijn, VOORDAT u met de montage begint | Haal alle onderdelen uit het pakket (of uit de pakketten) en leg ze op een schoon werkoppervlak | Bekijk alle montagehandleidingen | Monteer alle onderdelen volgens de aanwijzingen van deze handleiding. Sla geen stappen over.**

Leggere le linee guida di assistenza e sicurezza alla fine di questo manuale | Assicurarsi che non ci siano parti mancanti o danneggiate PRIMA di iniziare l'assemblaggio | Estrarre tutti i componenti dall'imballo e posizzarli su una superficie di lavoro pulita | Consultare tutte le istruzioni di montaggio | Assemblare tutti i componenti secondo le istruzioni contenute nel manuale. Non saltare nessuna fase.

**Leia as diretrizes de cuidados e segurança que constam da parte final deste manual | Verifique para se assegurar de que não há peças em falta ou danificadas ANTES de começar a preparar a montagem | Retire todas as peças da embalagem e espalhe-as numa superfície de trabalho limpa | Reveja todas as instruções de montagem | Monte todas as peças de acordo com as instruções do manual. Não salte quaisquer passos.**

**REQUIRED TOOLS | OUTILS EXIGÉS | HERRAMIENTAS NECESARIAS | BENÖTIGTE WERKZEUGE | BENODIGD GEREEDSCHAP | ATTREZZATURA OCCORRENTE | FERRAMENTAS NECESSÁRIAS**

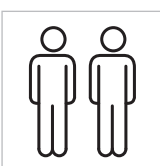
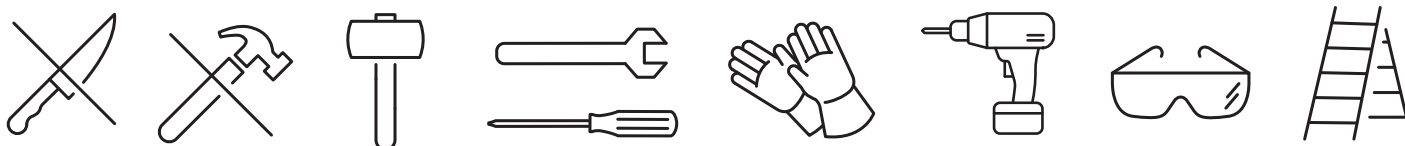

**ASSEMBLY REQUIRES TWO PEOPLE | LE MONTAGE DOIT ÊTRE EFFECTUÉ PAR DEUX PERSONNES | SE NECESITAN DOS PERSONAS PARA EL MONTAJE | ZWEI PERSONEN ZUR MONTAGE NOTWENDIG | MONTAGE VEREIST TWEETWEE PERSONEN | L'ASSEMBLAGGIO RICHIEDE DUE PERSONE | A MONTAGEM EXIGE DUAS PESSOAS**

**SHED PARTS | PIÈCES DE L'ABRI | PARTES DEL COBERTIZO | TEILE DES SCHUPPENS | ONDERDELEN VAN HET SCHUURTJE**  
**| COMPONENTI DELLA CASETTA | PEÇAS DO ABRIGO**

Remove all parts from the package(s) and spread them out on a clean work surface. Code letters are imprinted on each part for easy identification | Retirez toutes les pièces du/des paquet(s) et étalez-les sur une surface de travail propre. Des lettres sont imprimées sur chaque pièce pour une identification facile | Saque todas las piezas del paquete o paquetes y póngalas sobre una superficie de trabajo limpia. El código de letras está marcado en cada pieza para que sea más fácil identificarla | Nehmen Sie alle Teile aus der Verpackung und breiten Sie sie auf einer sauberen Arbeitsfläche aus. Auf jedem Teil sind Kennbuchstaben aufgedruckt, die die Zuordnung der einzelnen Teile erleichtern | Haal alle onderdelen uit het pakket (of uit de pakketten) en leg ze op een schoon werkoppervlak. Op ieder onderdeel zijn codes aangebracht om ze eenvoudig te kunnen herkennen | Rimuovere tutti i componenti dall'imballo e posizionarli su una superficie di lavoro pulita. I codici identificativi sono impressi in ogni componente per una semplice identificazione | Retire todas as peças da embalagem e espalhe-as numa superfície de trabalho limpa. Existem letras de código impressas em cada peça para fácil identificação

**FLOOR PARTS | ÉLÉMENTS DU PLANCHER | PARTES DEL SUELO | BODENTEILE | VLOERPANELEN | COMPONENTI DEL PAVIMENTO | PEÇAS DO CHÃO**

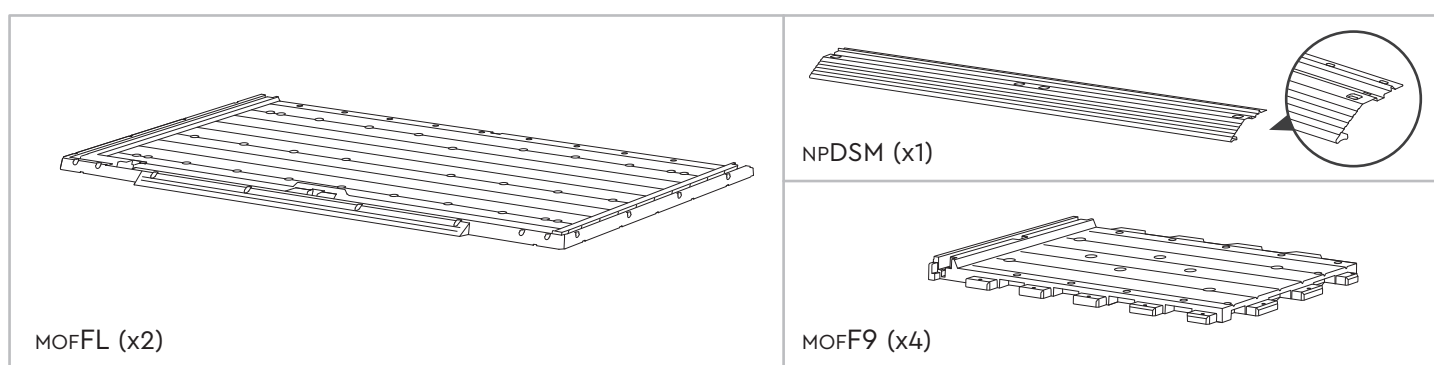

**WALL PARTS | PIÈCES DES MURS | PARTES DE LAS PAREDES | WANDELEMENTE | WAND ONDERDELEN | COMPONENTI DELLE PARETI | PAINÉIS LATERAIS**

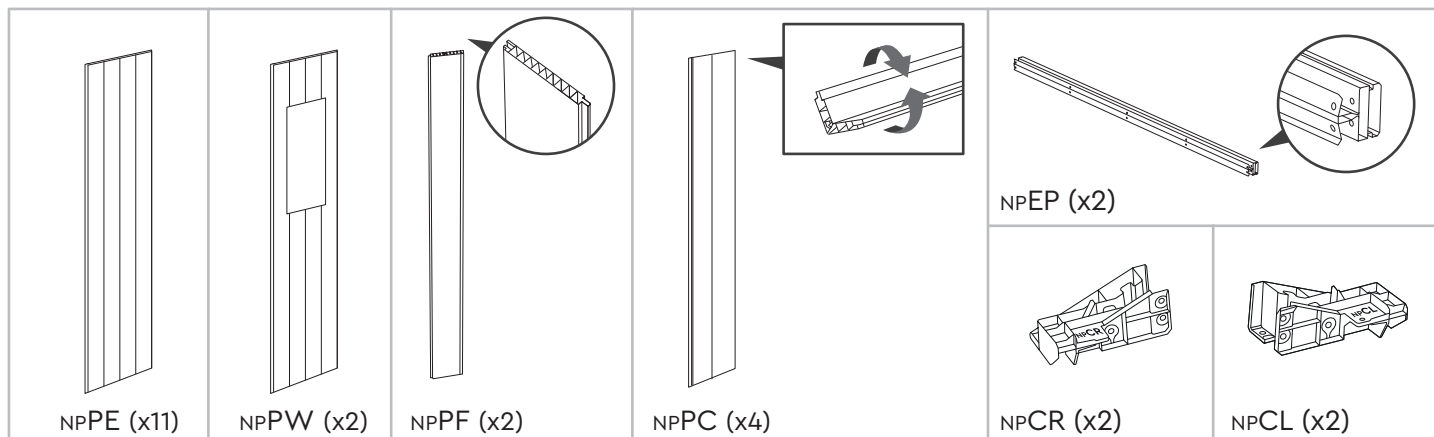

**DOOR PARTS | PIÈCES DE LA PORTE | PARTES DE LA PUERTA | TÜRELEMENTE | DEURONDERDELEN | COMPONENTI DELLA PORTA | PEÇAS DAS PORTAS**

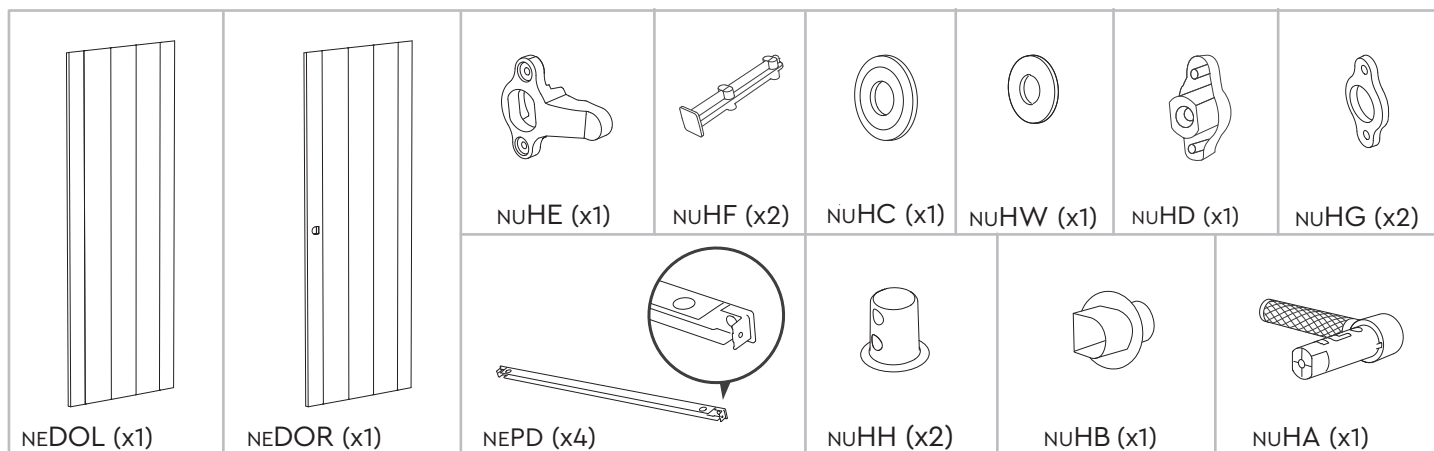

**ROOF PARTS | PIÈCES DU TOIT | PARTES DEL TECHO | DACHELEMENTE | DAKONDERDELEN | COMPONENTI DEL TETTO | PEÇAS DO TELHADO**

NPZ3 (x1)	NPZ2 (x1)	NPZ1 (x1)	NPZ6 (x1)	NPZ5 (x1)	NPZ4 (x1)
MOFTU (x2)		MOFTD (x2)		MOFT9 (x4)	
MOB7 (x1)			OKEXT (x1)		









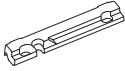

**WINDOW PARTS | PIÈCES DE LA FENÊTRE | PARTES DE LA VENTANA | FENSTERELEMENTE | RAAMONDERDELEN | COMPONENTI DELLE FINESTRE | PEÇAS DA JANELA**

SMWF (x2)	MOWB (x2)	SMWG (x4)
-----------	-----------	-----------

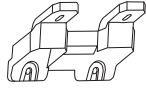
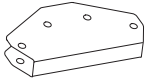

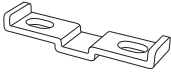
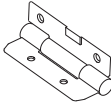

**METAL PARTS | PIÈCES MÉTALLIQUES | PIEZAS METÁLICAS | METALLTEILE | METALEN DELEN | COMPONENTI IN METALLO | PARTES METÁLICAS**

NPMP (x5)	NPLDF (x1)	
MOMG (x4)	NPRDF (x1)	
MOFM7 (x4)	NWDSO (x2)	
MOM11 (x2)	NWDSI (x1)	
NEMB (x2)	NWDSW (x1)	
NPUDF (x1)	MOMH (x2)	NP5M (x1)

**SMALL PARTS | PETITES PIÈCES | PARTES PEQUEÑAS | KLEINTEILE | KLEINE ONDERDELEN | MINUTERIA | PEÇAS PEQUENAS**

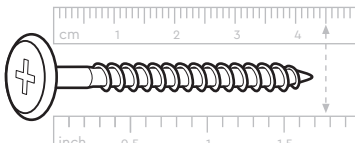
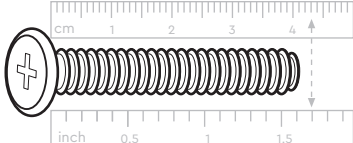
 NPDS (x1)	 KP (x16)	 NPGSS (x4)
 MOAK (x2)	 FNTM (x8)	 MOFTC (x4)
 MOAMA (x2)	 MOPLS (x2)	 MOBC9 (x1)
 MOAC (x2)	 MORC (x6)	 NEDH (x6)
		 NEDPC (x2)

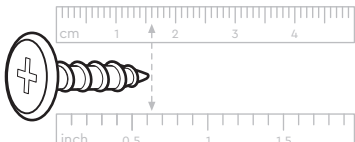
**SCREWS | VIS | TORNILLOS | SCHRAUBEN | SCHROEVEN | VITI | PARAFUSOS**

 s45b (x52) 45 mm / 1.77"	 sc8 (x31) 43 mm / 1.69"	 scn8 (x31)
 sc15 (x353) 16 mm / 0.63"	 sc7t (x14) 7 mm / 0.28"	 s13b (x108) 12 mm / 0.47"

**Packaging may contain some additional small parts for use as spare parts | L'emballage peut contenir de petites pièces supplémentaires à utiliser comme pièces de rechange | El envoltorio puede contener algunas piezas pequeñas adicionales que se pueden utilizar como repuestos | In der Verpackung können kleine Zusatzteile enthalten sein, die als Ersatzteile genutzt werden können | De verpakking kan een aantal kleine extra onderdelen bevatten, die als reserveonderdeel gebruikt kunnen worden | L'imballo potrebbe contenere piccoli componenti supplementari da utilizzare come ricambistica | A embalagem pode conter algumas pequenas peças adicionais para utilização como peças de reposição**

**NOTE:** Due to variations in production, the actual assembled size may vary slightly from the specified dimensions.  
**REMARQUE:** En raison de variantes dans la production, la taille de montage réelle peut différer quelque peu des dimensions indiquées.  
**NOTA:** debido a las variaciones en la producción, el tamaño real al montarlo puede variar ligeramente con respecto a las dimensiones especificadas.  
**BITTE BEACHTEN:** Aufgrund von Abweichungen in der Herstellung kann die tatsächliche Größe leicht von den angegebenen Maßen abweichen.  
**LET OP:** vanwege afwijkingen in de productie kan de werkelijke afmeting na montage een klein beetje afwijken van de opgegeven afmetingen  
**NOTA:** A causa di variazioni nella produzione, le dimensioni effettive del prodotto assemblato potrebbero variare leggermente da quelle indicate.  
**NOTA:** Devido a variações na produção o tamanho real da montagem poderá variar ligeiramente das dimensões especificadas.

FLOOR ASSEMBLY | MONTAGE DU PLANCHER | MONTAJE DEL SUELO | MONTAGE DER BODENPLATTE | VLOERMONTAGE | ASSEMBLAGGIO DEL PAVIMENTO | MONTAGEM DO PISO

1

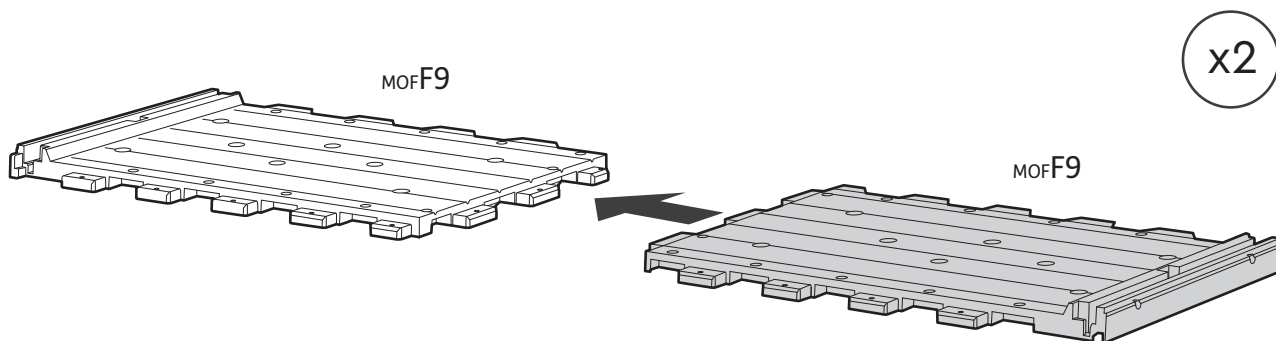
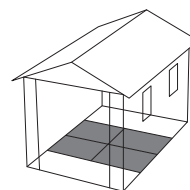

2

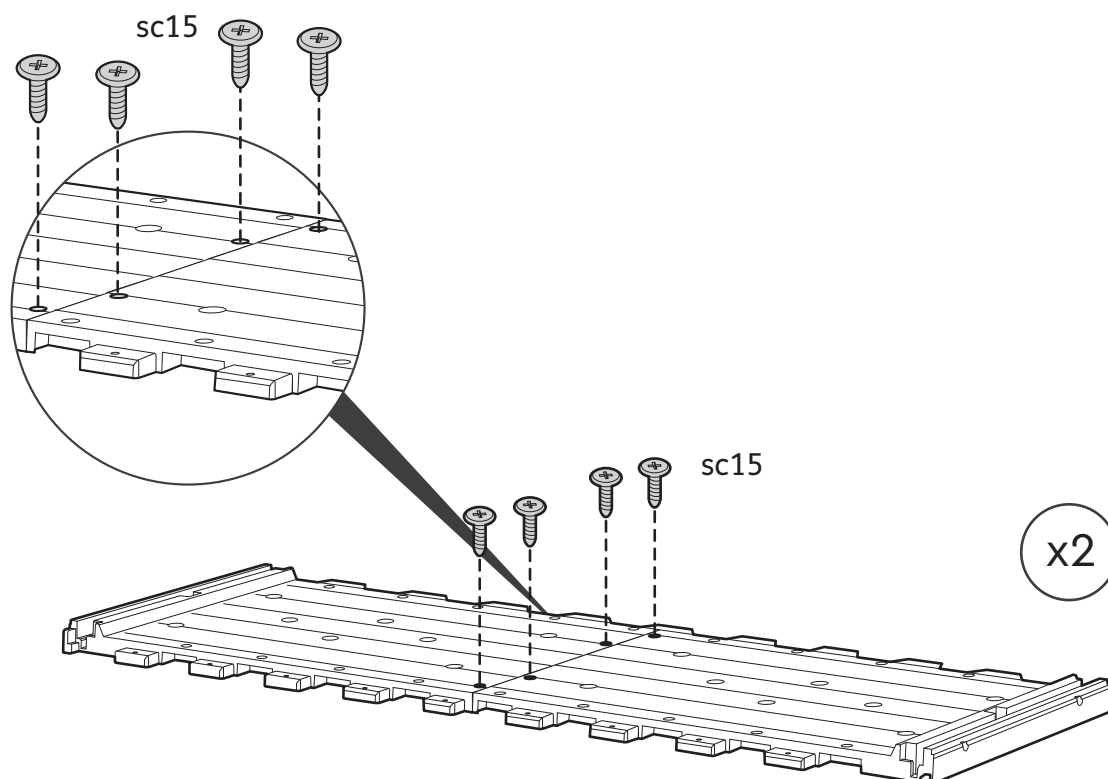
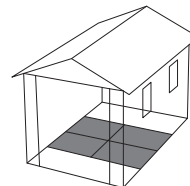

3

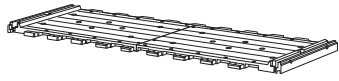

(x2)

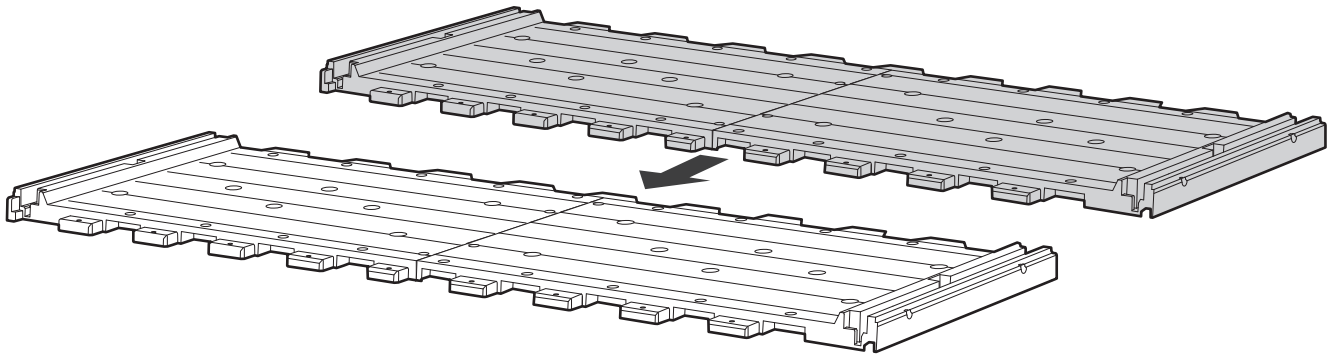
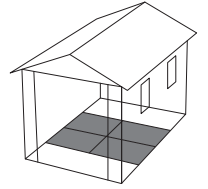

4

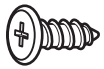

sc15 (x18)

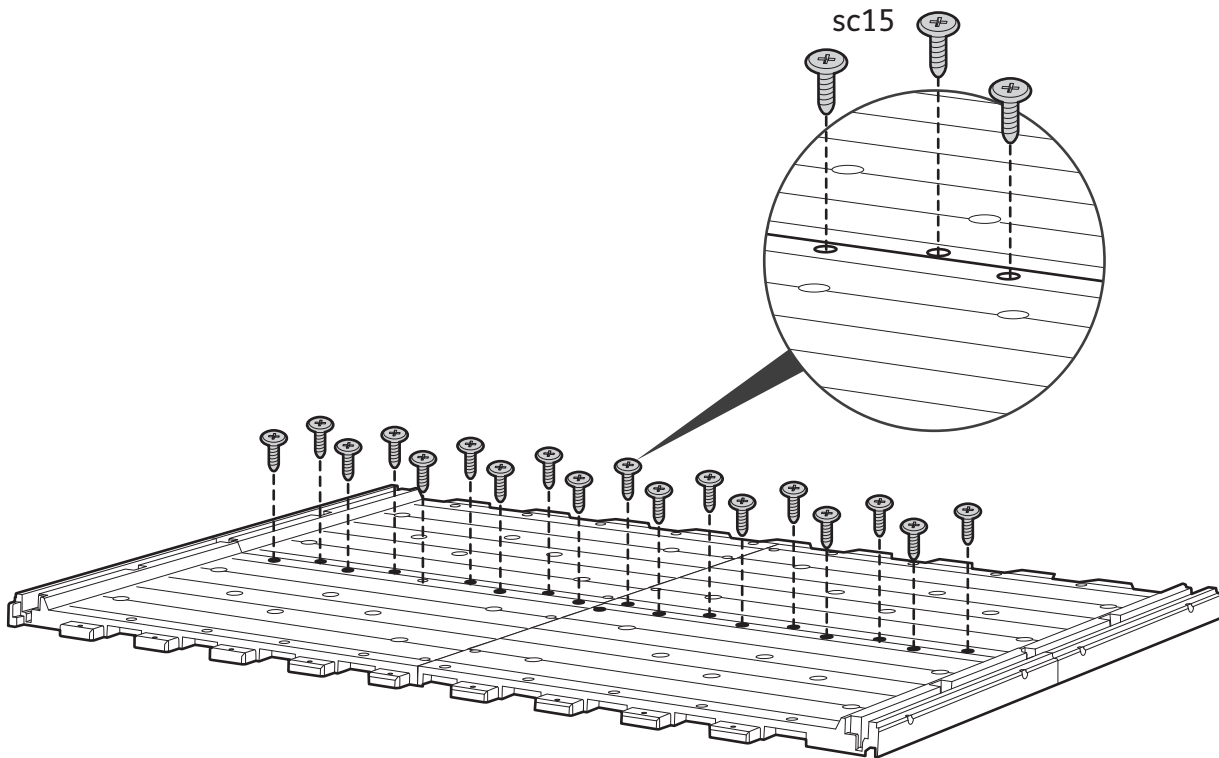
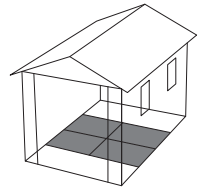

5

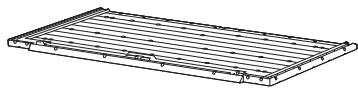
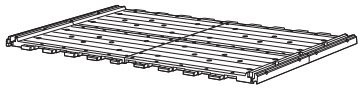

MOFL (x2)

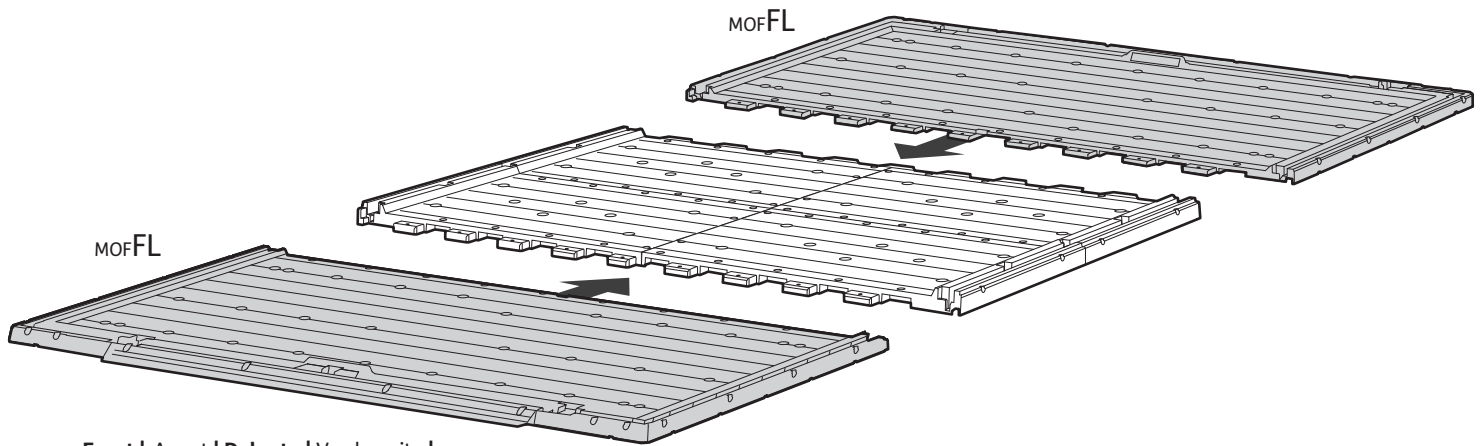
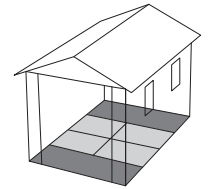

Front | Avant | Delante | Vorderseite |  
Voorkant | Anteriore | Frente

6



sc15 (x36)

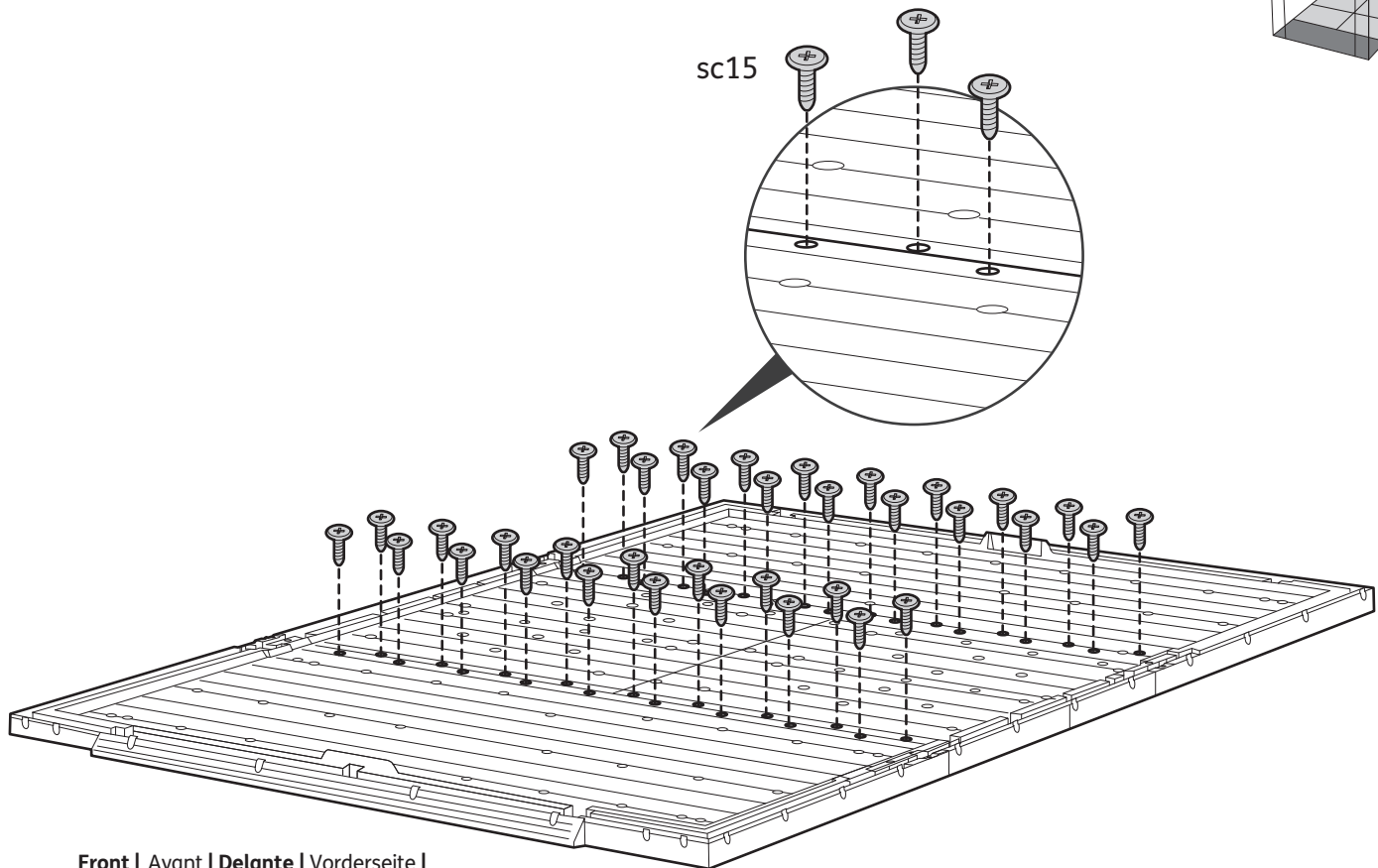
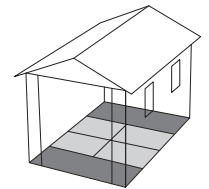

Front | Avant | Delante | Vorderseite |  
Voorkant | Anteriore | Frente

7

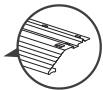

NPDSM (x1)



sc15 (x6)

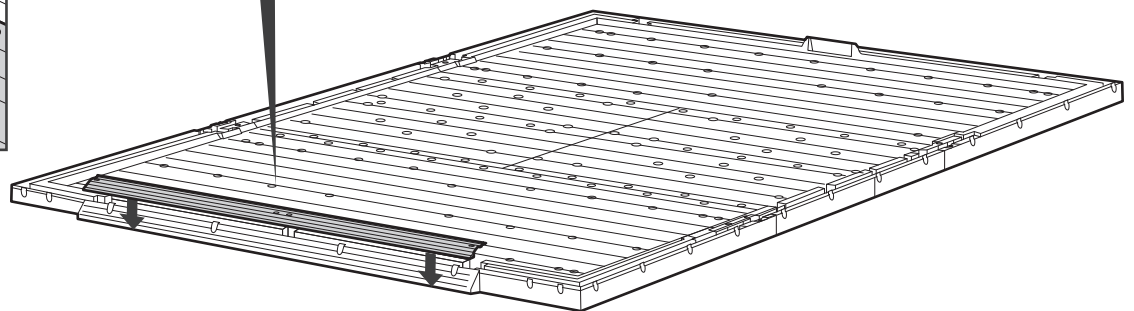
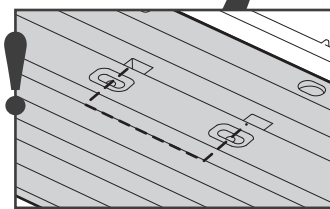
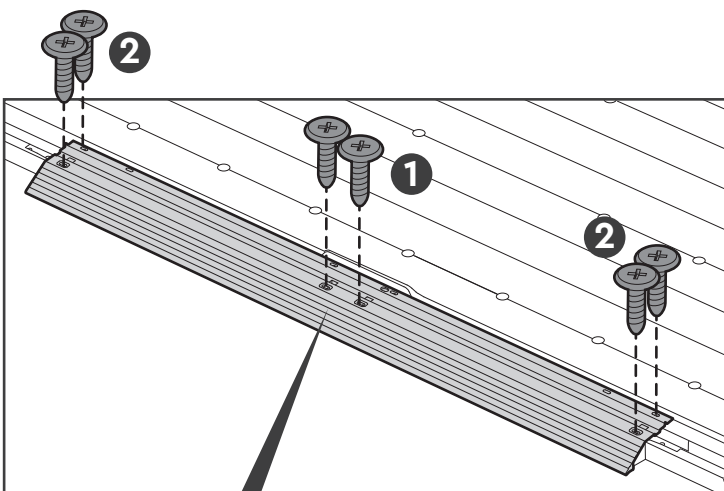
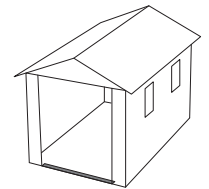

8

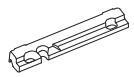

NPDS (x1)



sc15 (x2)

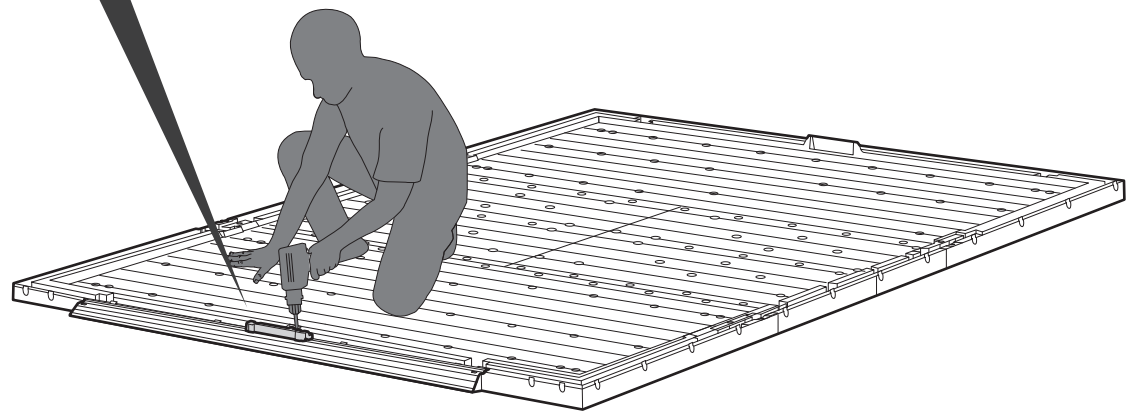
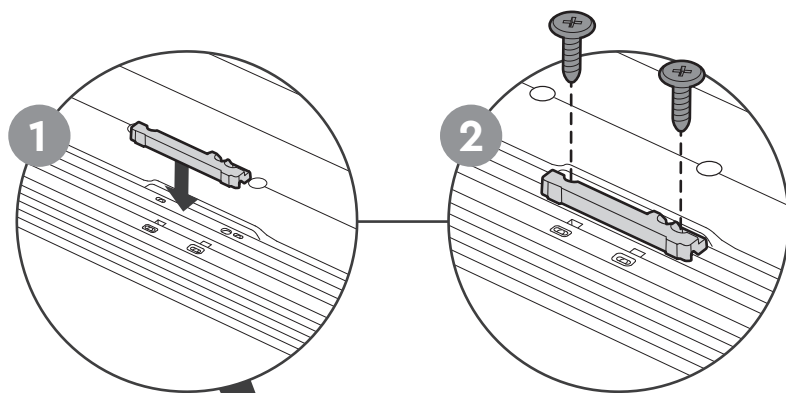
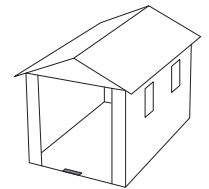

**WALL ASSEMBLY | MONTAGE DU MUR | MONTAJE DE LAS | MONTAGE DER WÄNDE | MONTAGE VAN DE MUREN | ASSEMBLAGGIO DELLE PARETI | MONTAGEM DA PAREDE**

**CHOOSE THE LOCATION OF THE WINDOW | CHOISISSEZ L'EMPLACEMENT DE LA FENÊTRE | ELIJA DÓNDE QUIERE COLOCAR LA VENTANA | WÄHLEN SIE AUS, WO SIE DAS FENSTER ANBRINGEN MÖCHTEN | KIES WAAR U HET VENSTER WILT HEBBEN | SCEGLIERE LA POSIZIONE DELLA FINESTRA | ESCOLHA ONDE QUER COLOCAR A JANELA**

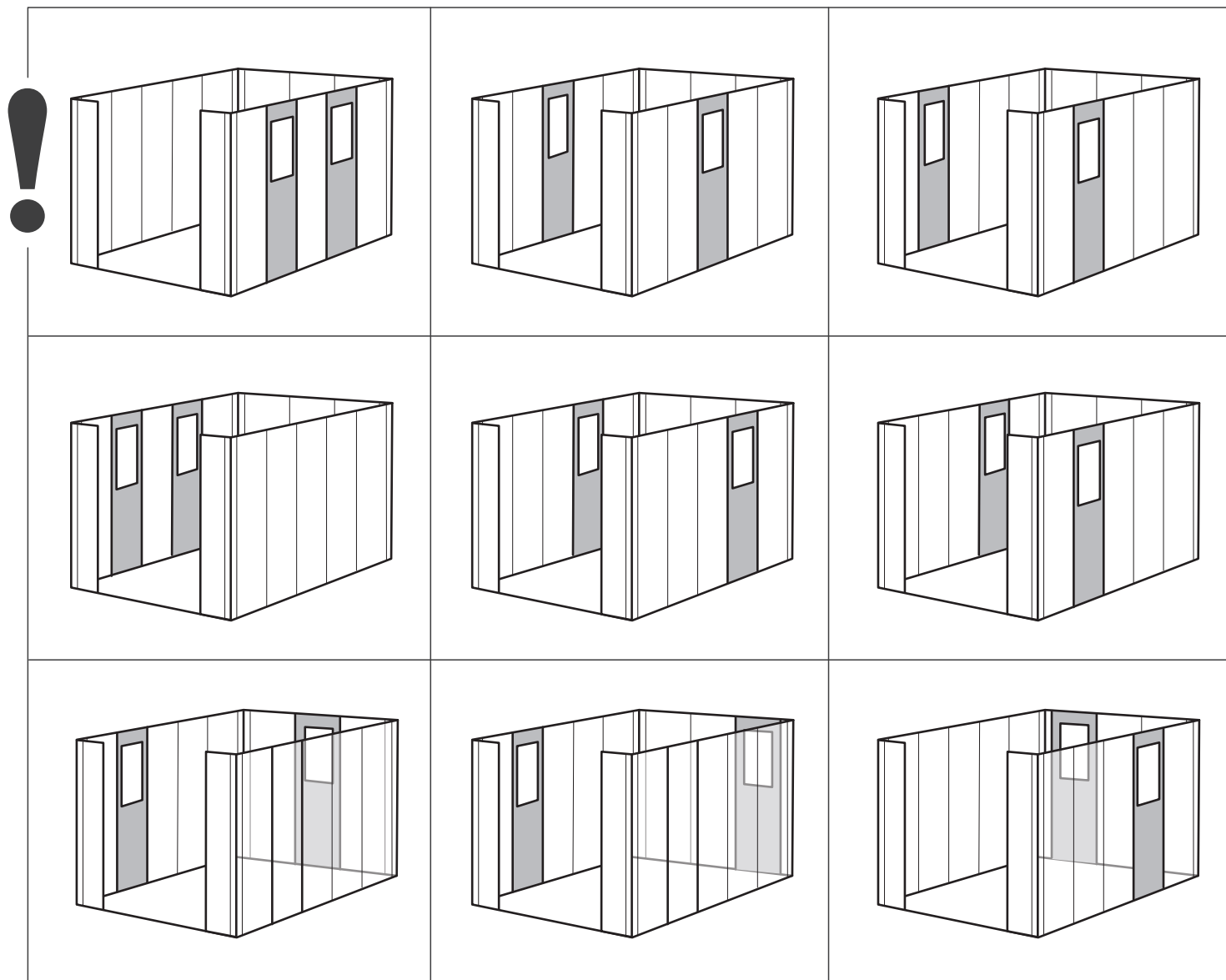

9



NPPC (x1)



NPPE (x1)

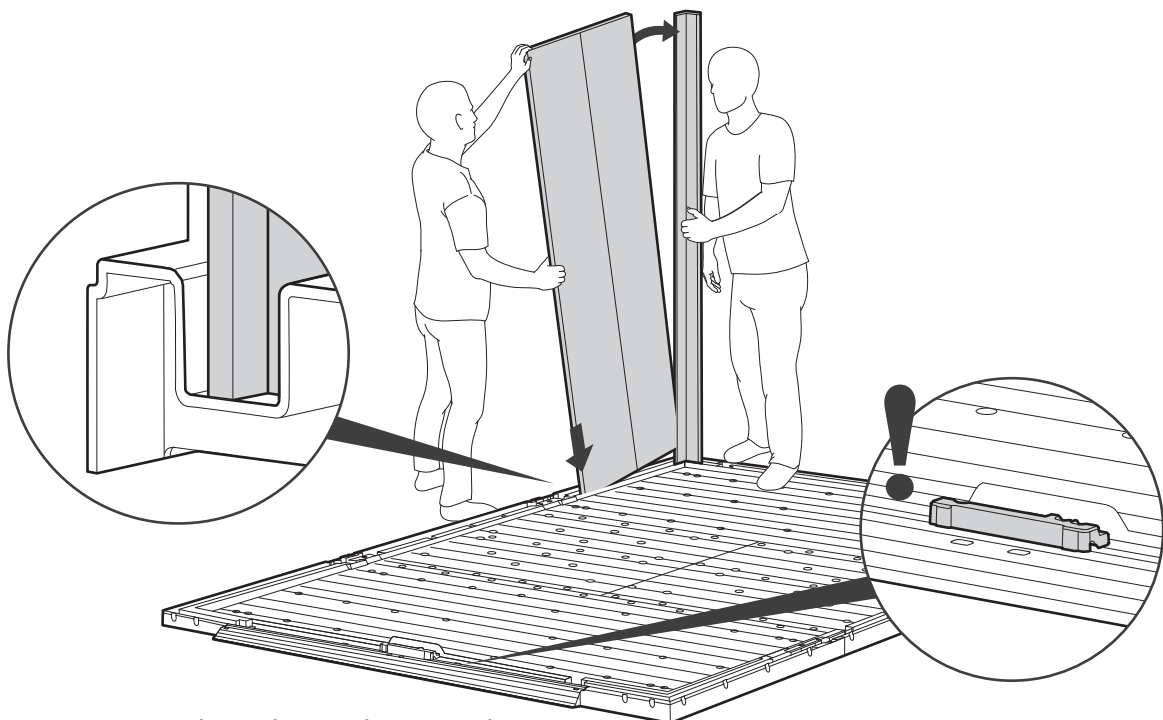
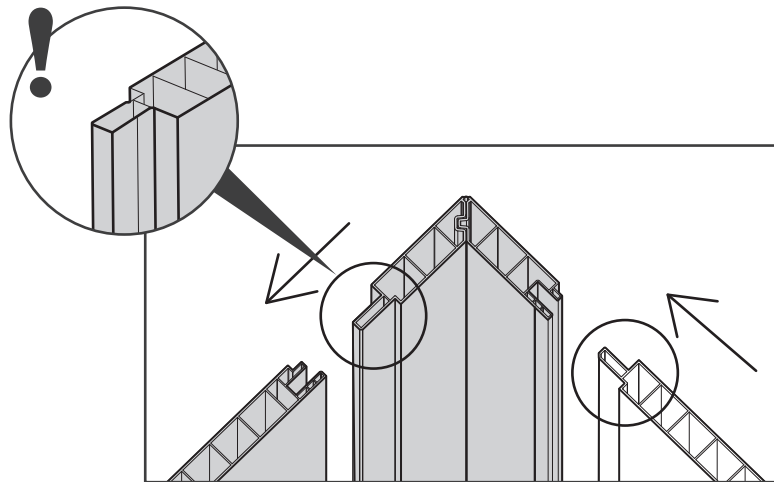
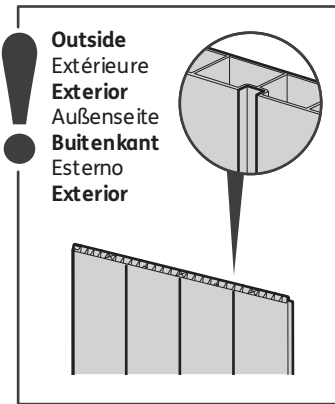
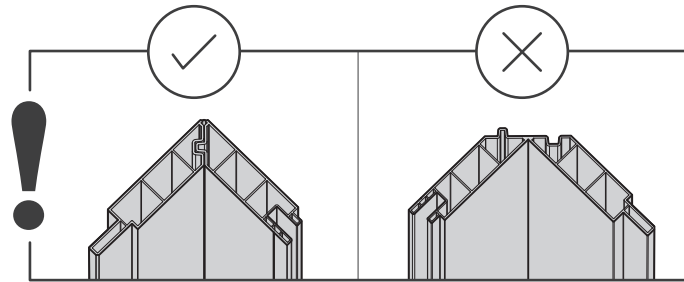
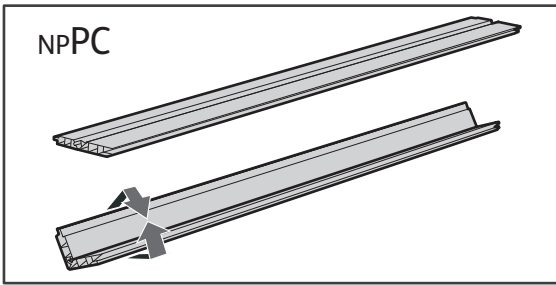
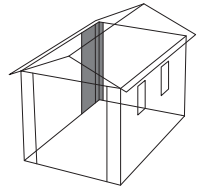

**Front | Avant | Delante | Vorderseite |  
Voorkant | Anteriore | Frente**

10



KP (x1)



s13b (x1)

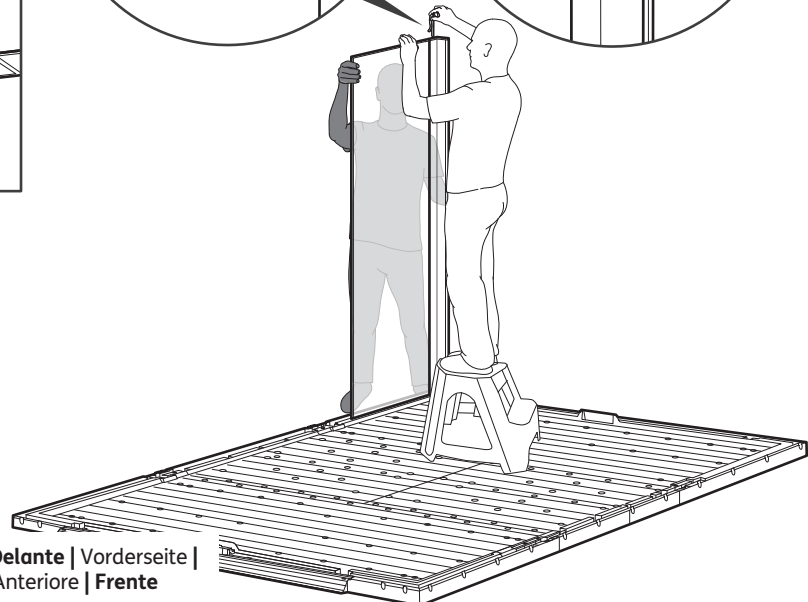
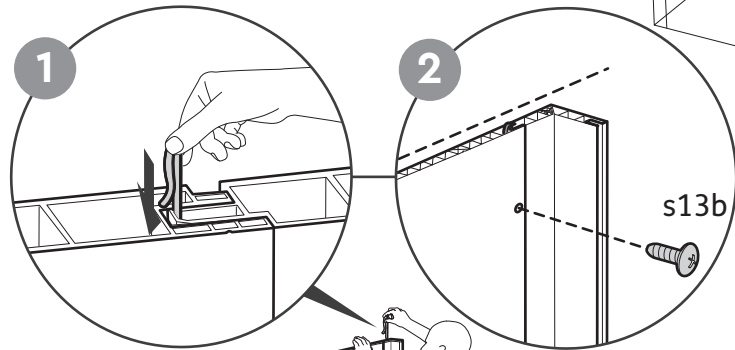
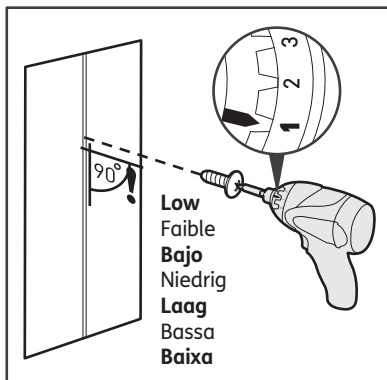
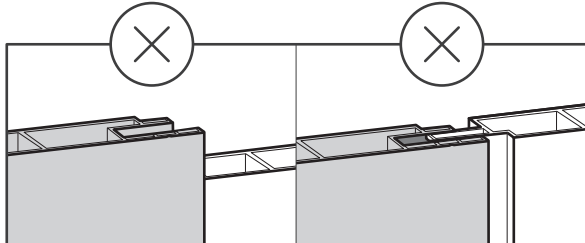
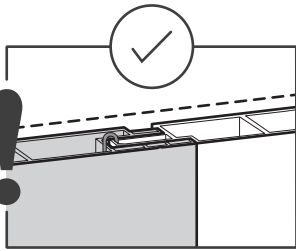
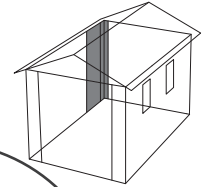

Front | Avant | Delante | Vorderseite |  
Voorkant | Anteriore | Frente

11



NPPE (x1)

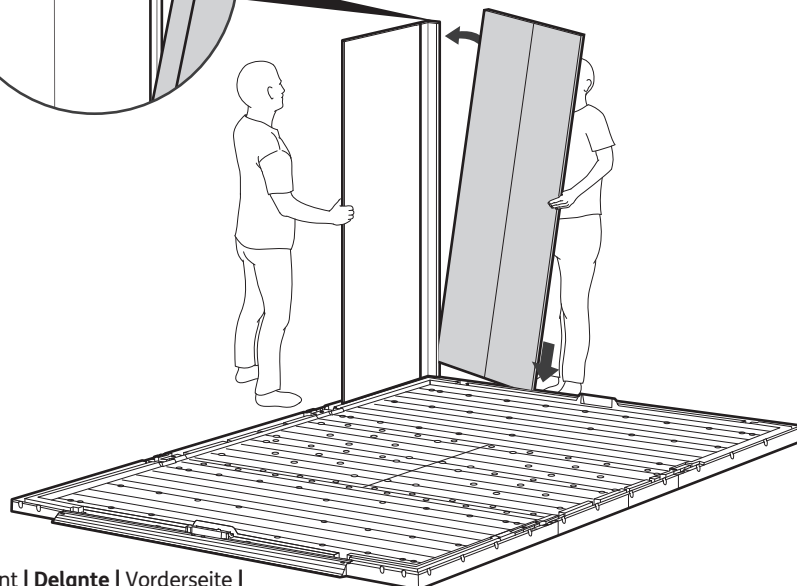
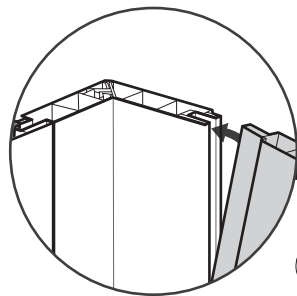
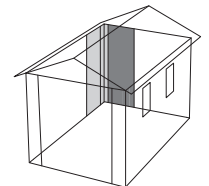

Front | Avant | Delante | Vorderseite |  
Voorkant | Anteriore | Frente

12

KP (x1)

s13b (x1)

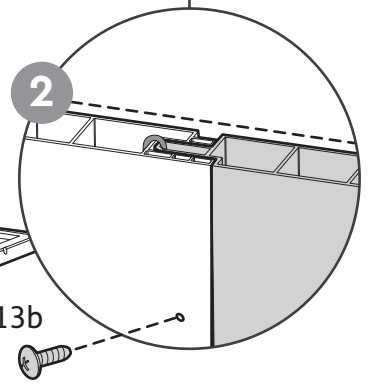
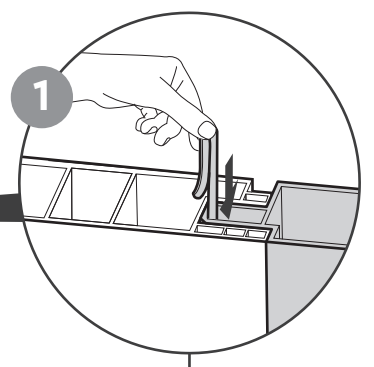
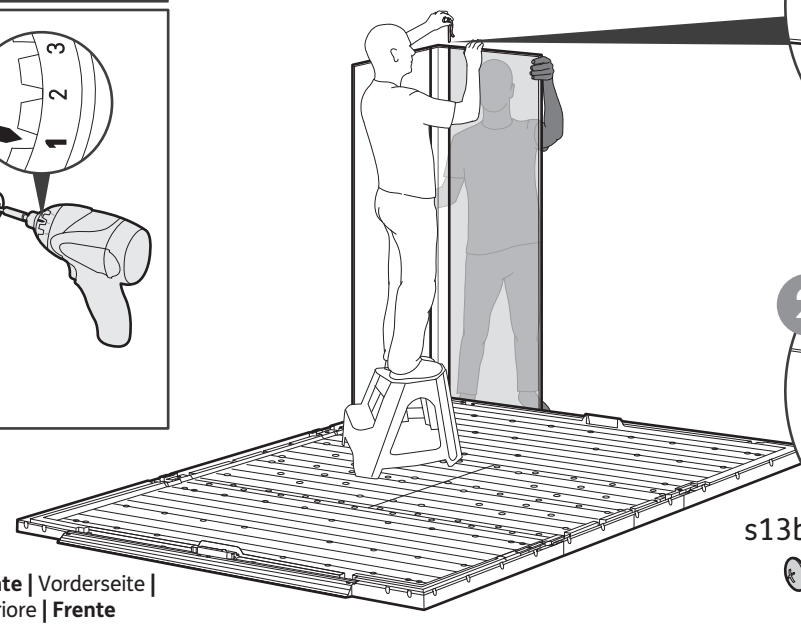
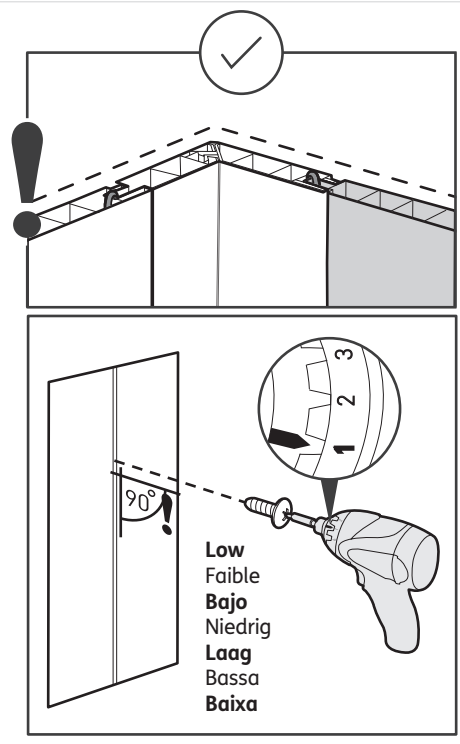
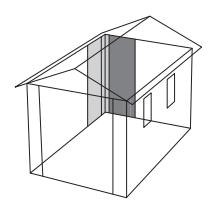

Front | Avant | Delante | Vorderseite |  
Voorkant | Anteriore | Frente

13

NPPE (x2)

KP (x2)

s13b (x2)

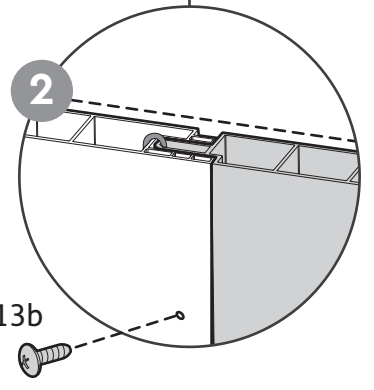
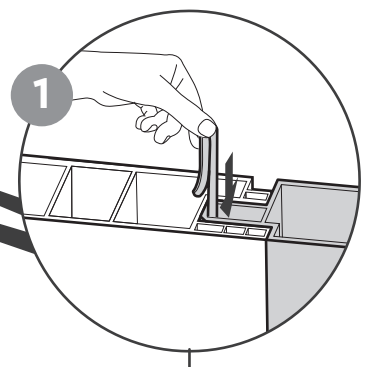
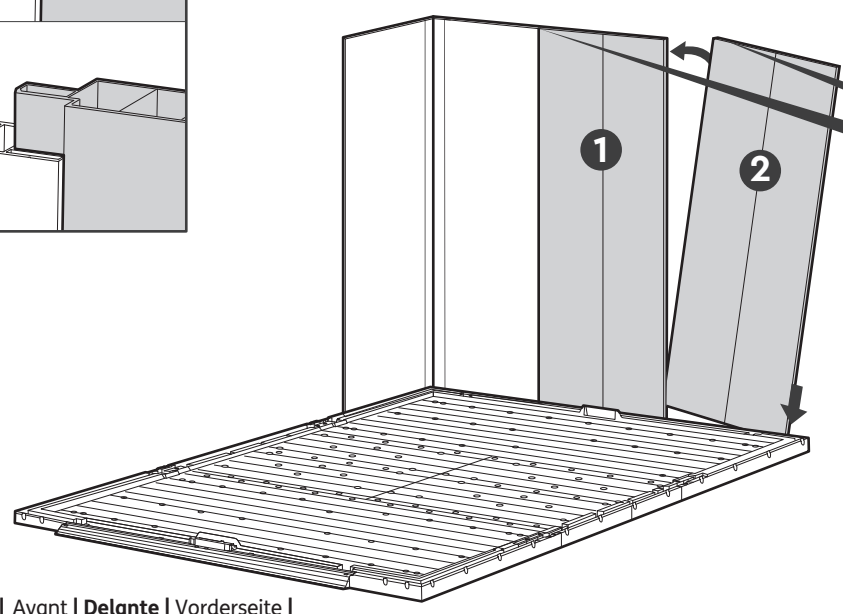
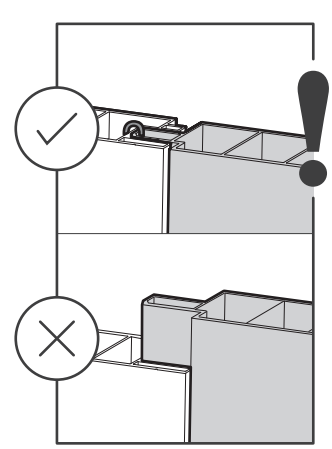
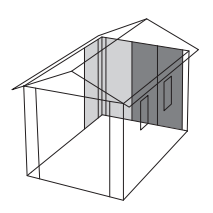

Front | Avant | Delante | Vorderseite |  
Voorkant | Anteriore | Frente

14



NPPC (x1)



KP (x1)

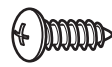

s13b (x1)

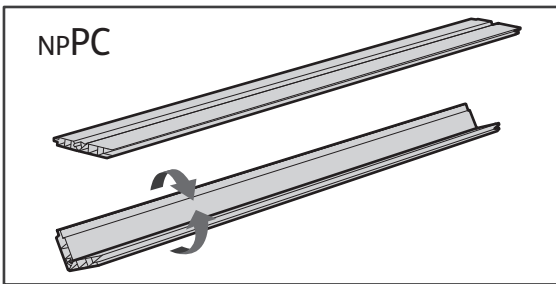
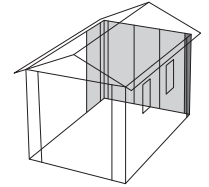

NPPC

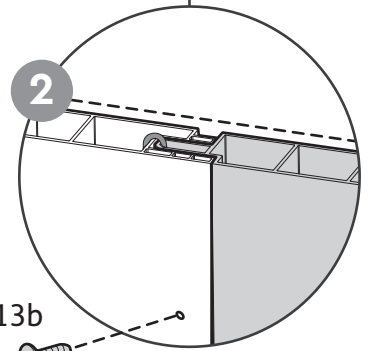
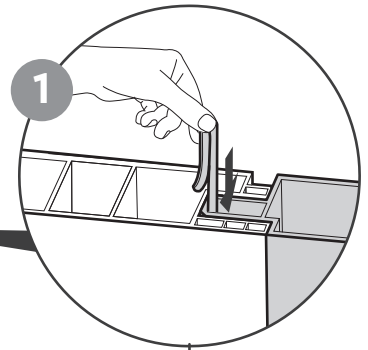
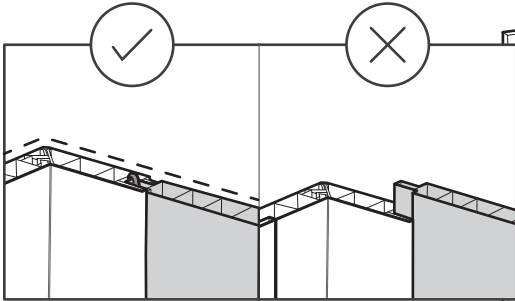

s13b



Front | Avant | Delante | Vorderseite |  
Voorkant | Anteriore | Frente

15



NPPE (x1)



KP (x1)

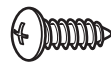

s13b (x1)

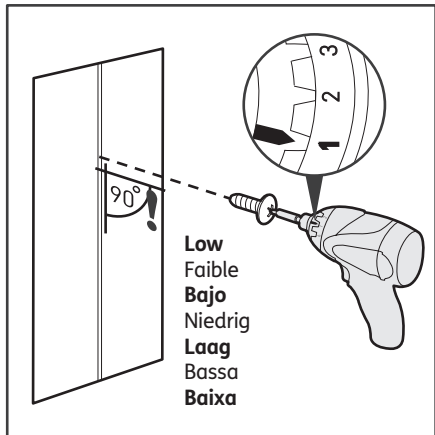
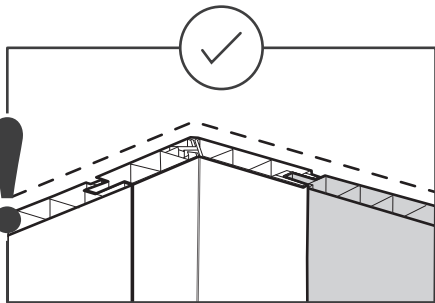
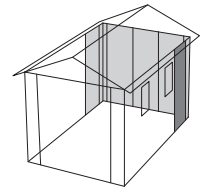

Low  
Faible  
Bajo  
Niedrig  
Laag  
Bassa  
Baixa

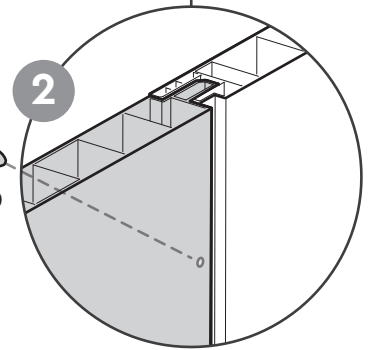
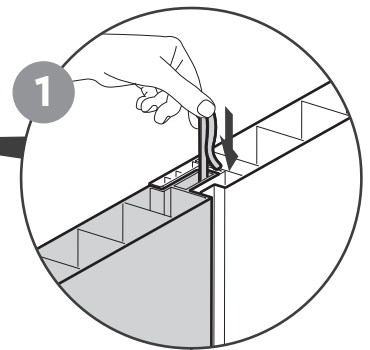

s13b

Front | Avant | Delante | Vorderseite |  
Voorkant | Anteriore | Frente

16



NPPW (x1)



KP (x1)



s13b (x1)

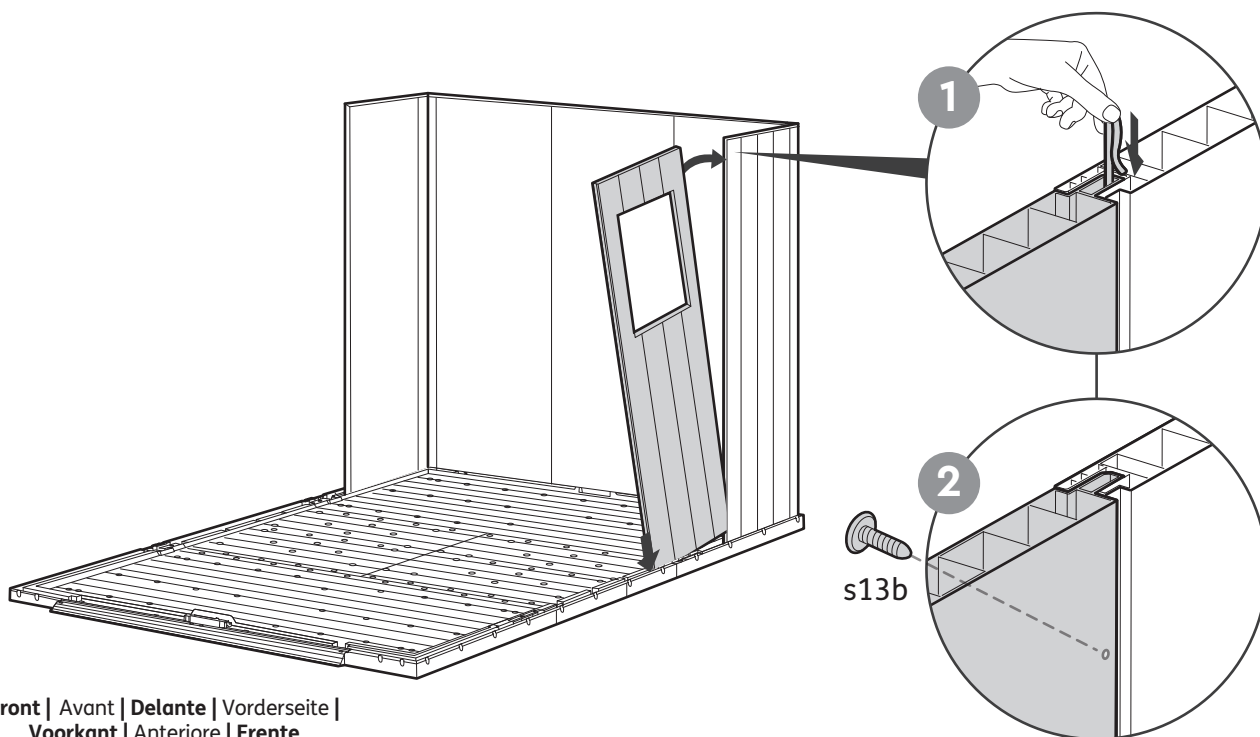
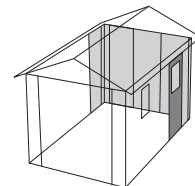

Front | Avant | Delante | Vorderseite |  
Voorkant | Anteriore | Frente

17



NPPE (x3)



KP (x3)



s13b (x3)

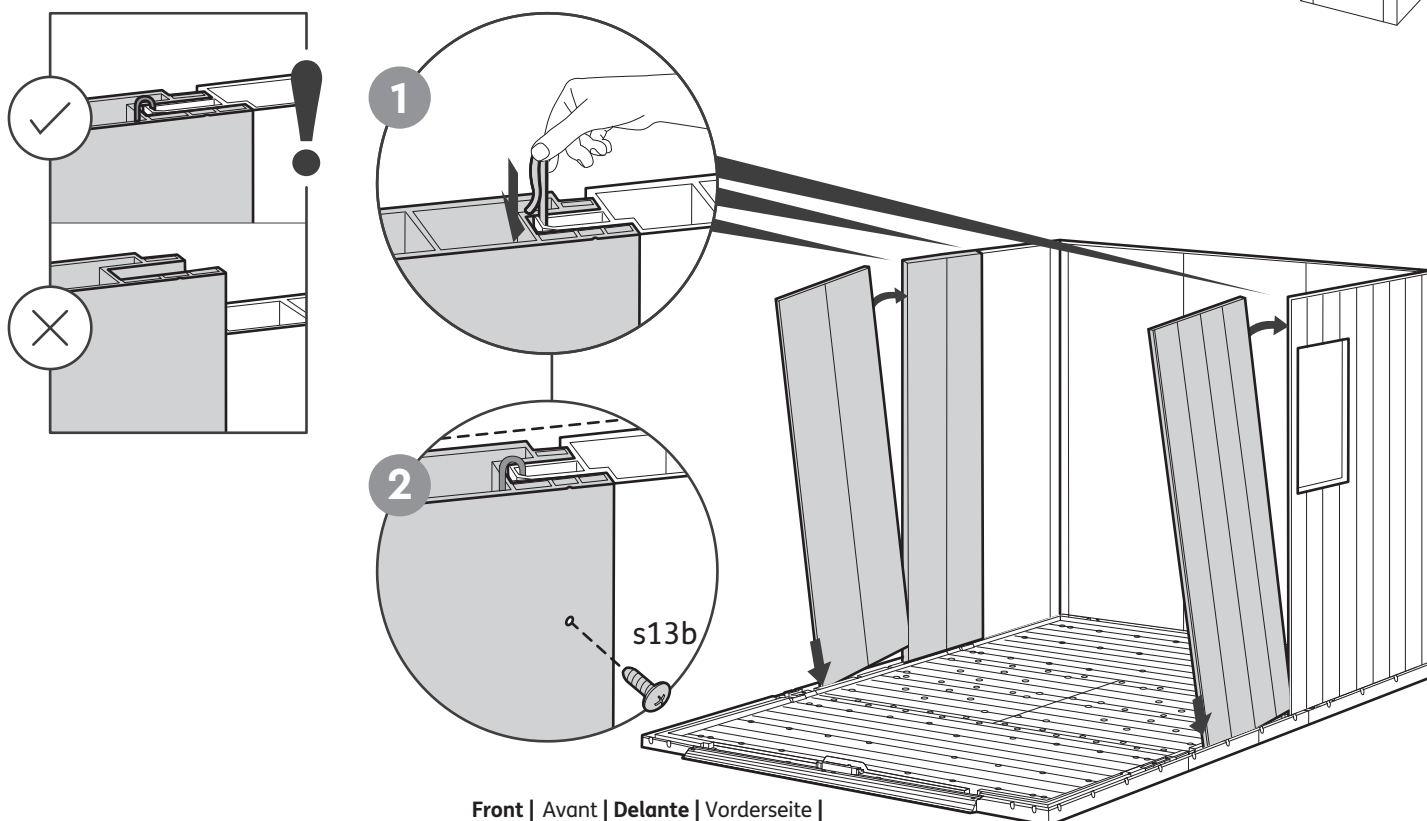
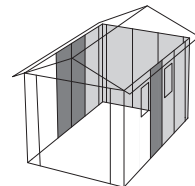

Front | Avant | Delante | Vorderseite |  
Voorkant | Anteriore | Frente

18



NPPW (x1)



NPPE (x1)



KP (x2)

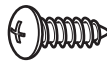

s13b (x2)

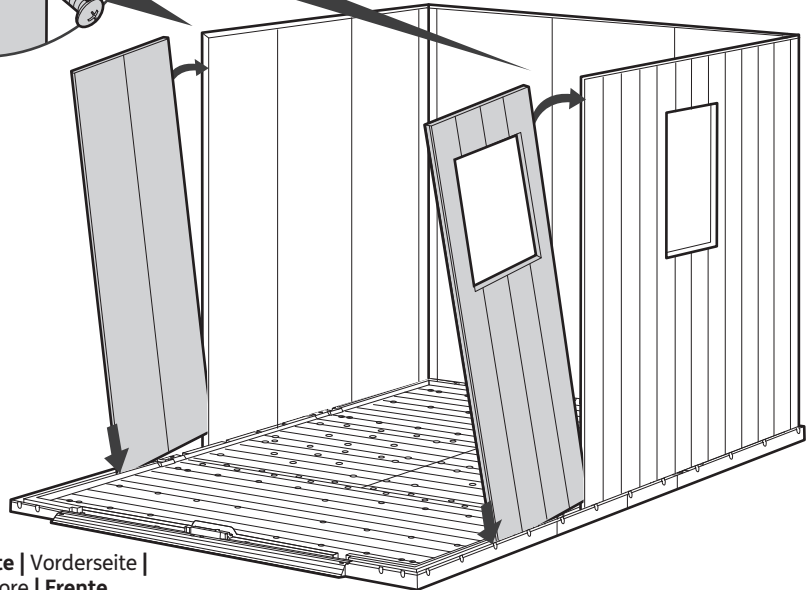
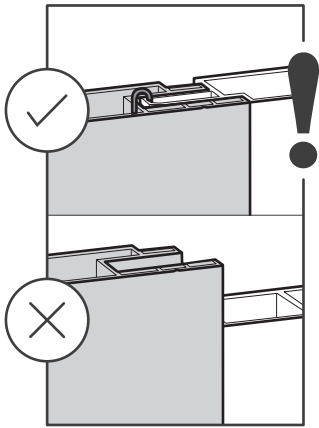
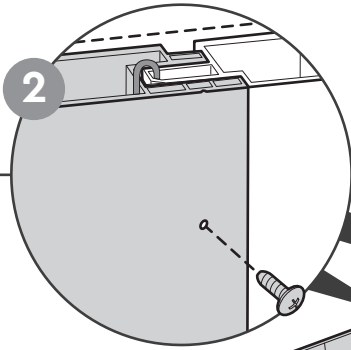
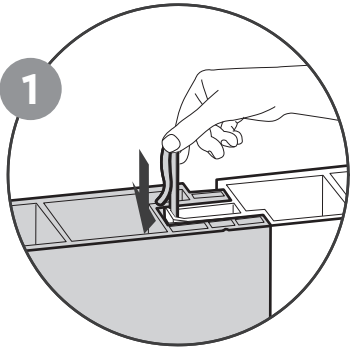
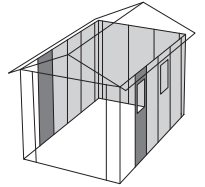

Front | Avant | Delante | Vorderseite |  
Voorkant | Anteriore | Frente

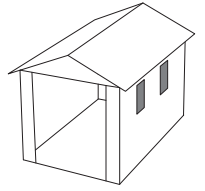

19



SMWF (x2)

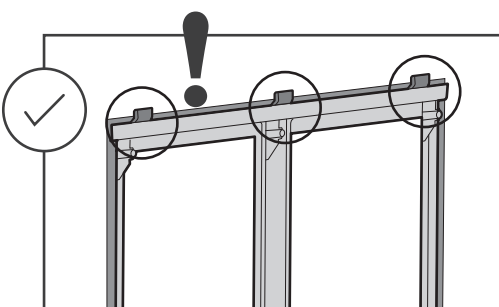
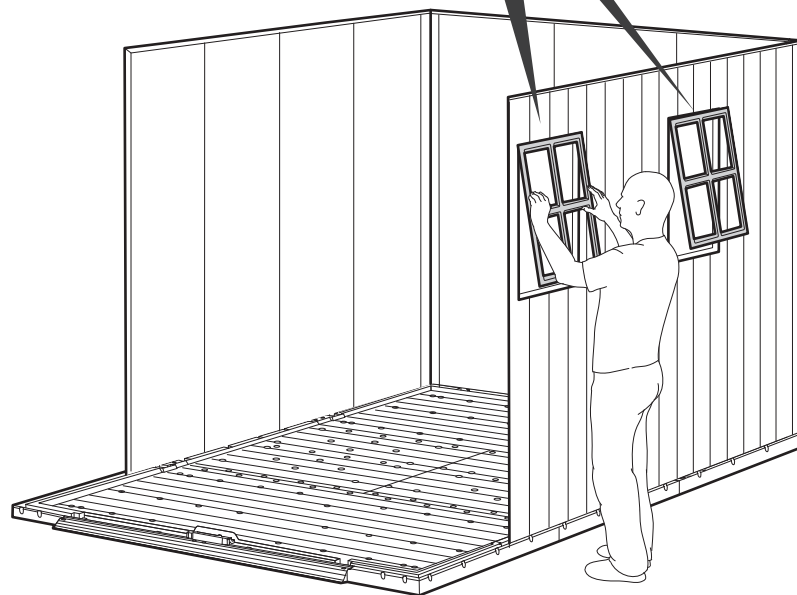
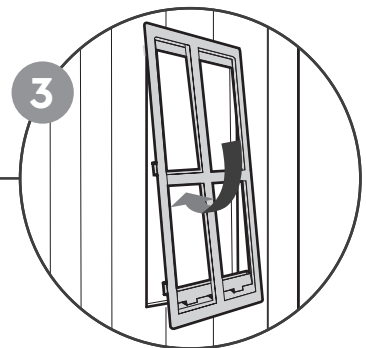
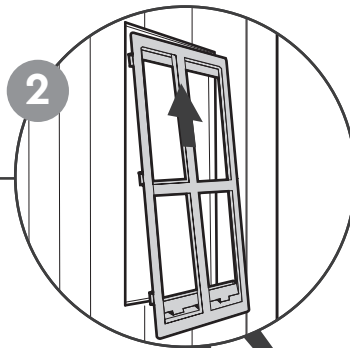
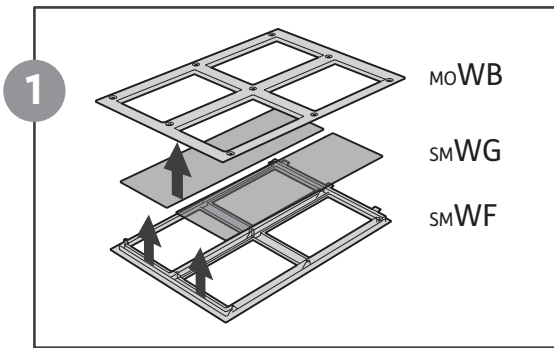
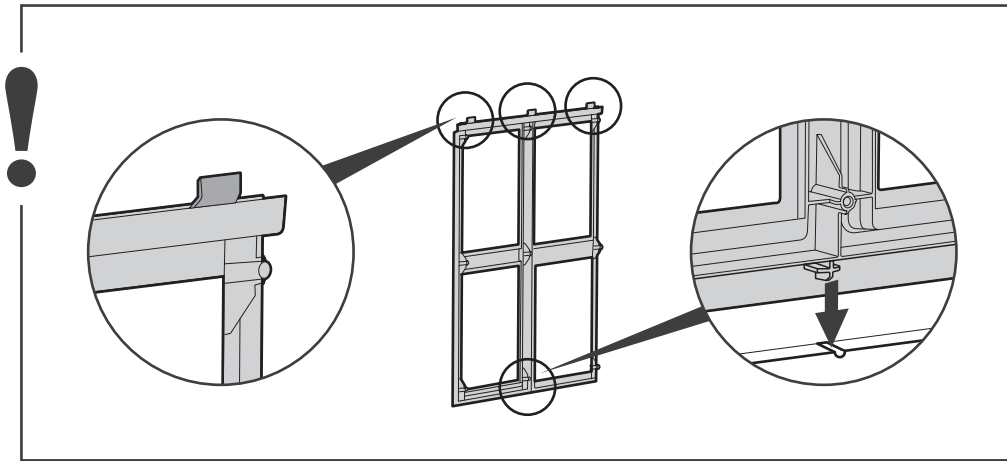

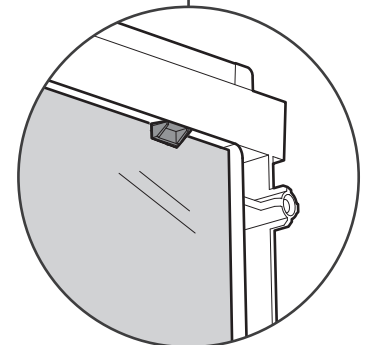
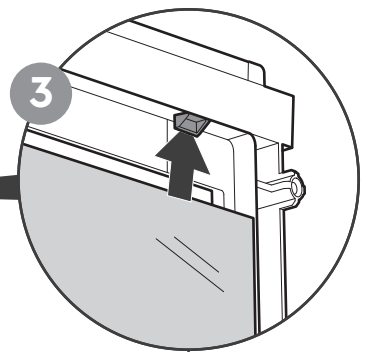
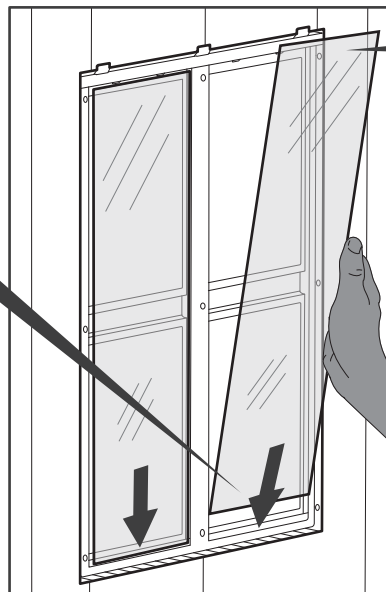
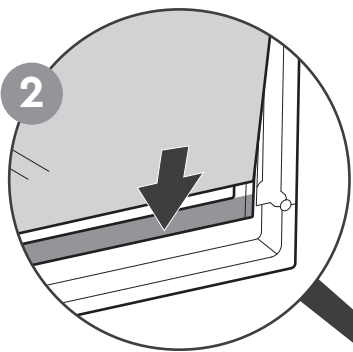
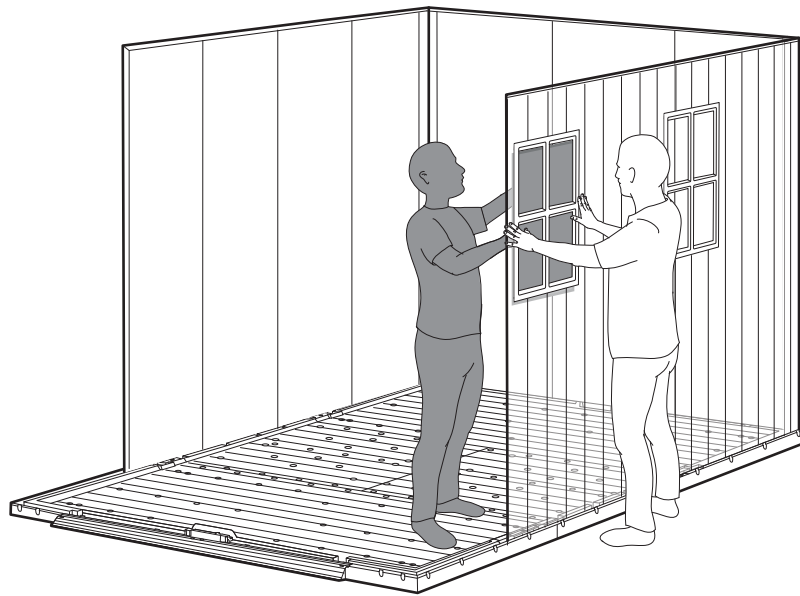
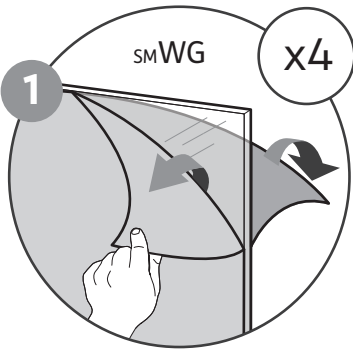
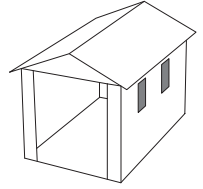

! Inside  
 Intérieur  
 Interior  
 Innenseite  
 Binnenkant  
 Interno  
 Interior

21



MoWB (x2)



sc15 (x18)

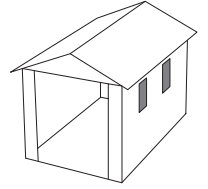

**!** Inside | Intérieur | Interior | Innenseite  
Binnenkant | Interno | Interior

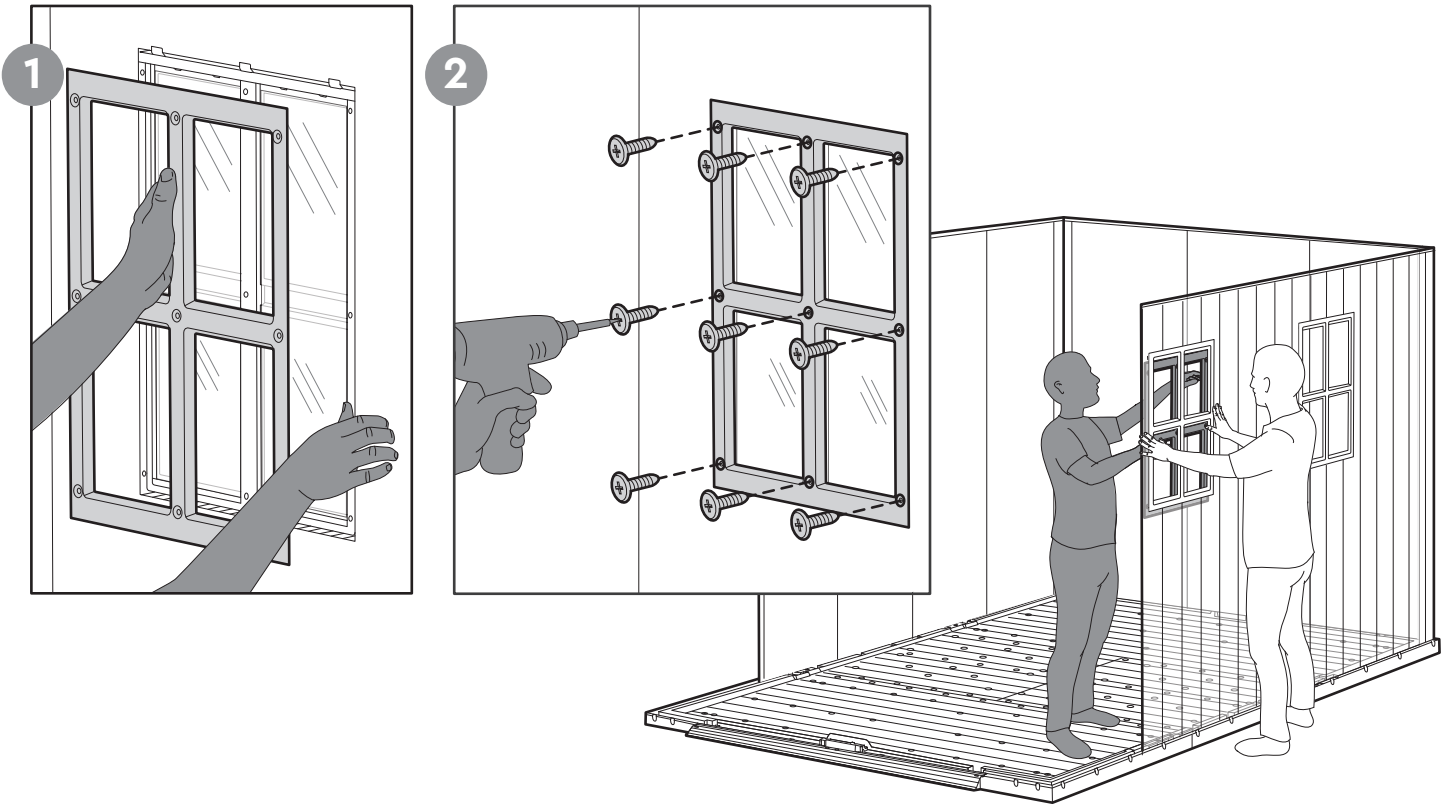

22



NPMP (x4)



NPGSS (x4)



sc8 (x8)



scn8 (x8)



NPGS (x2)

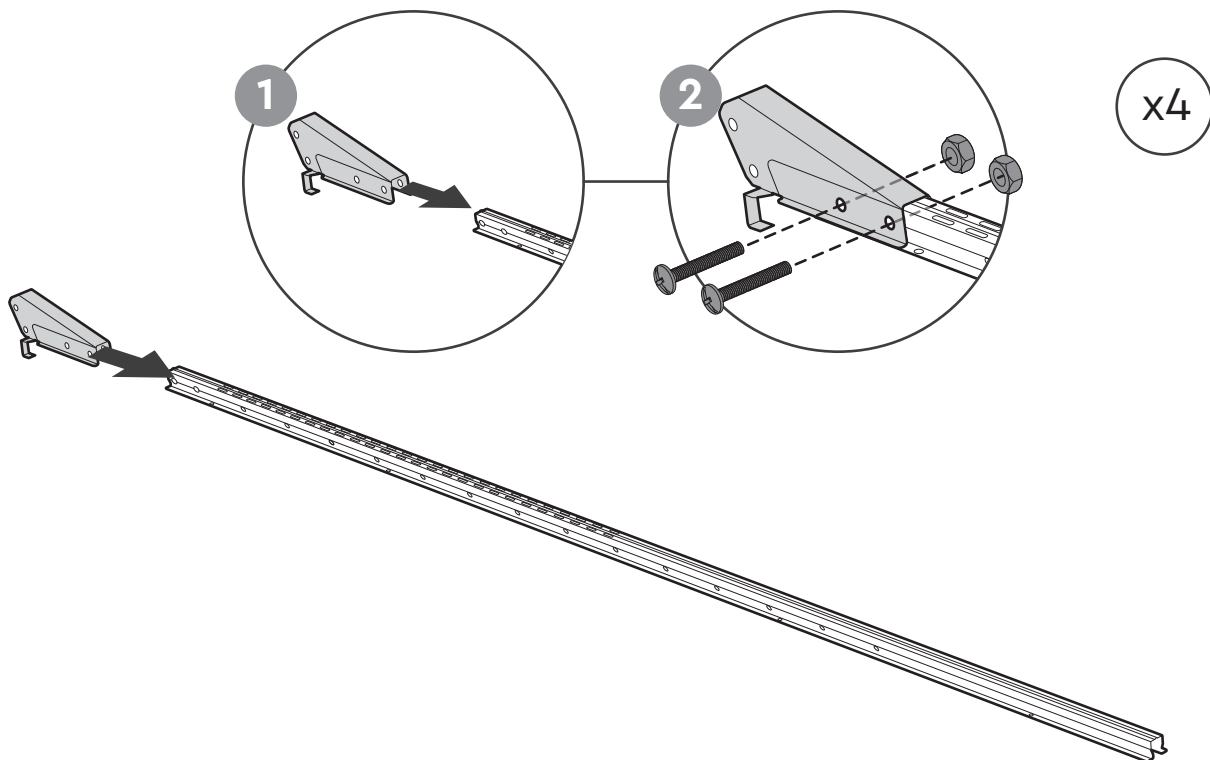
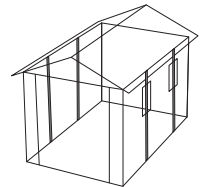

23

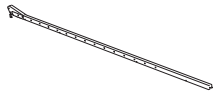

(x4)

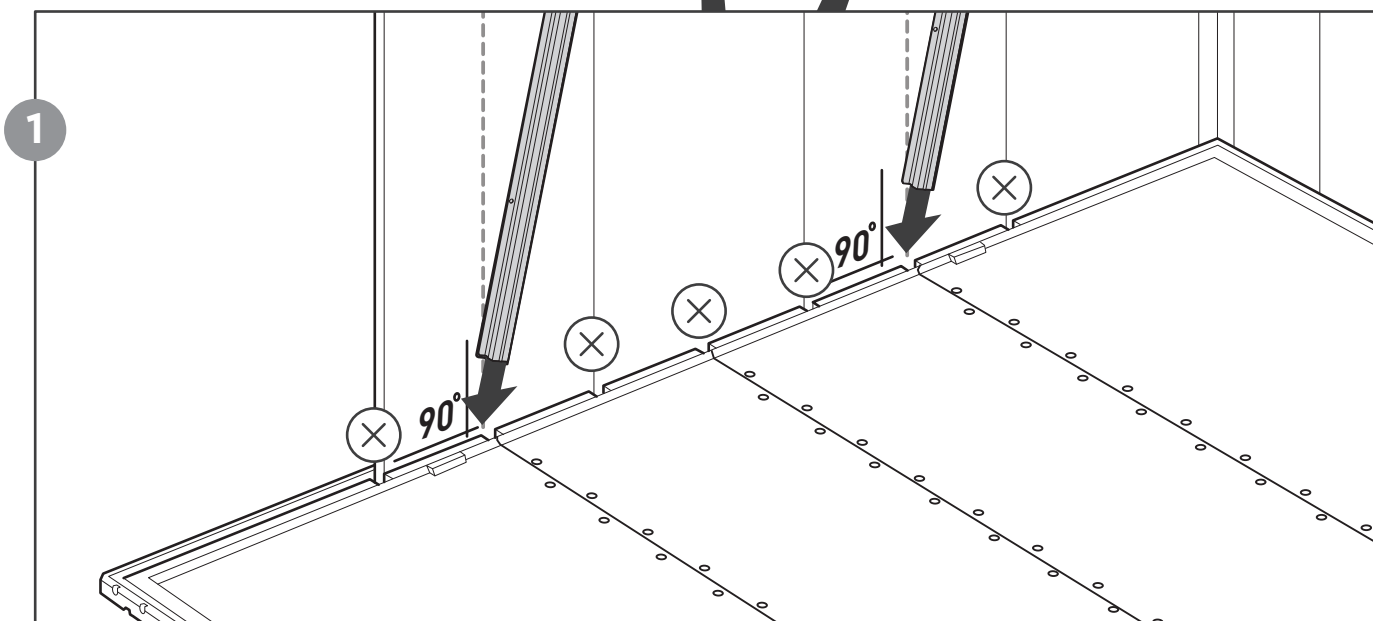
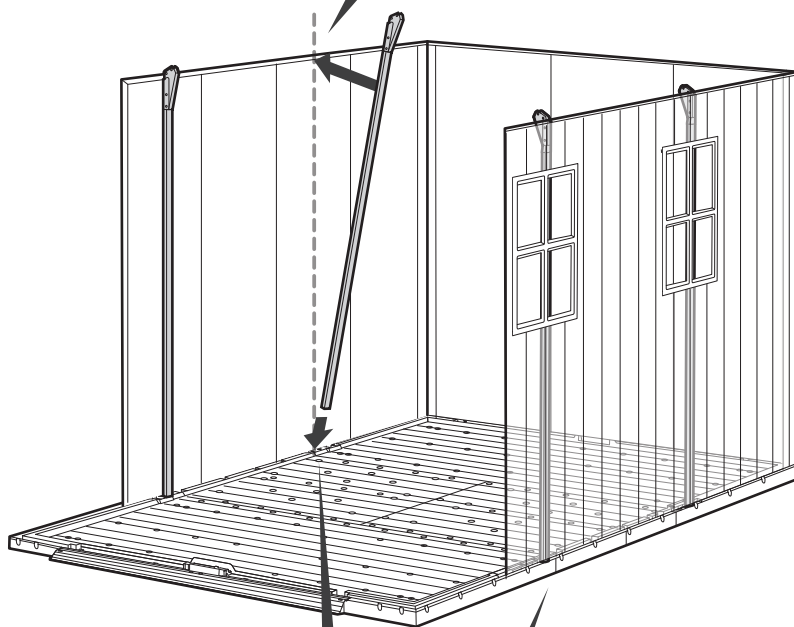
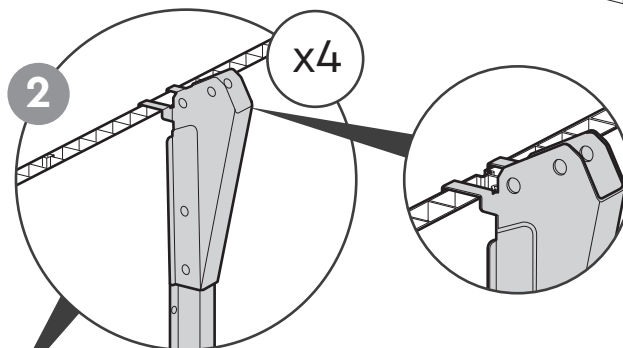
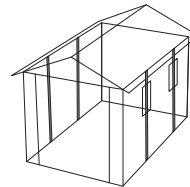

1

24

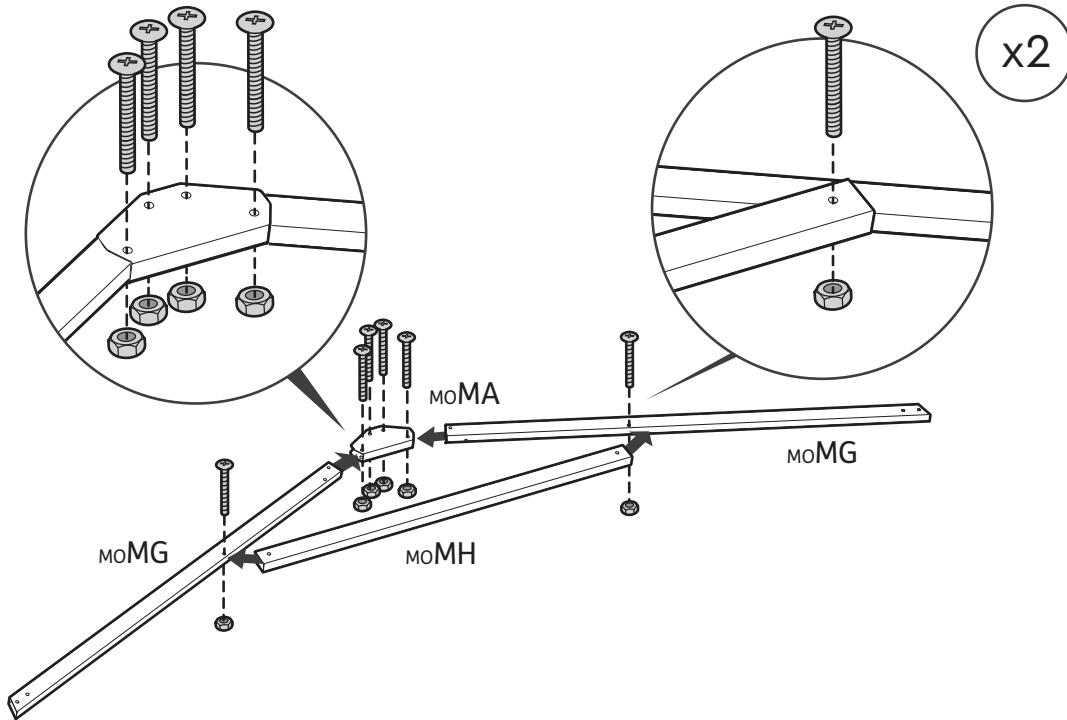
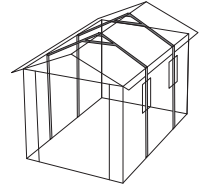
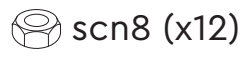
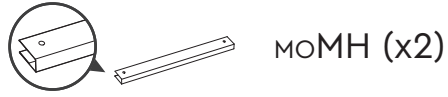

25

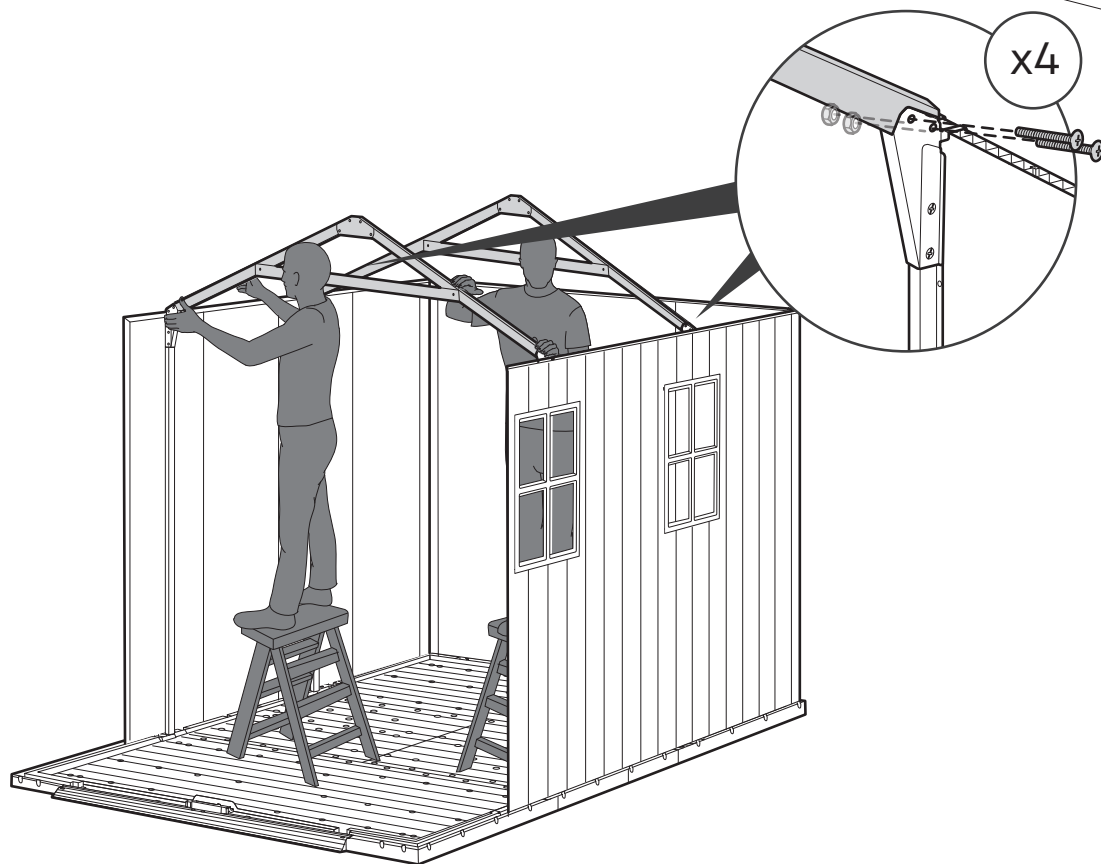
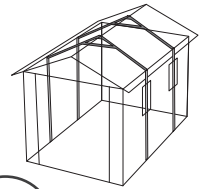
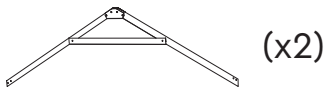

26



NPPE (x2)



KP (x2)

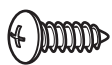

s13b (x2)

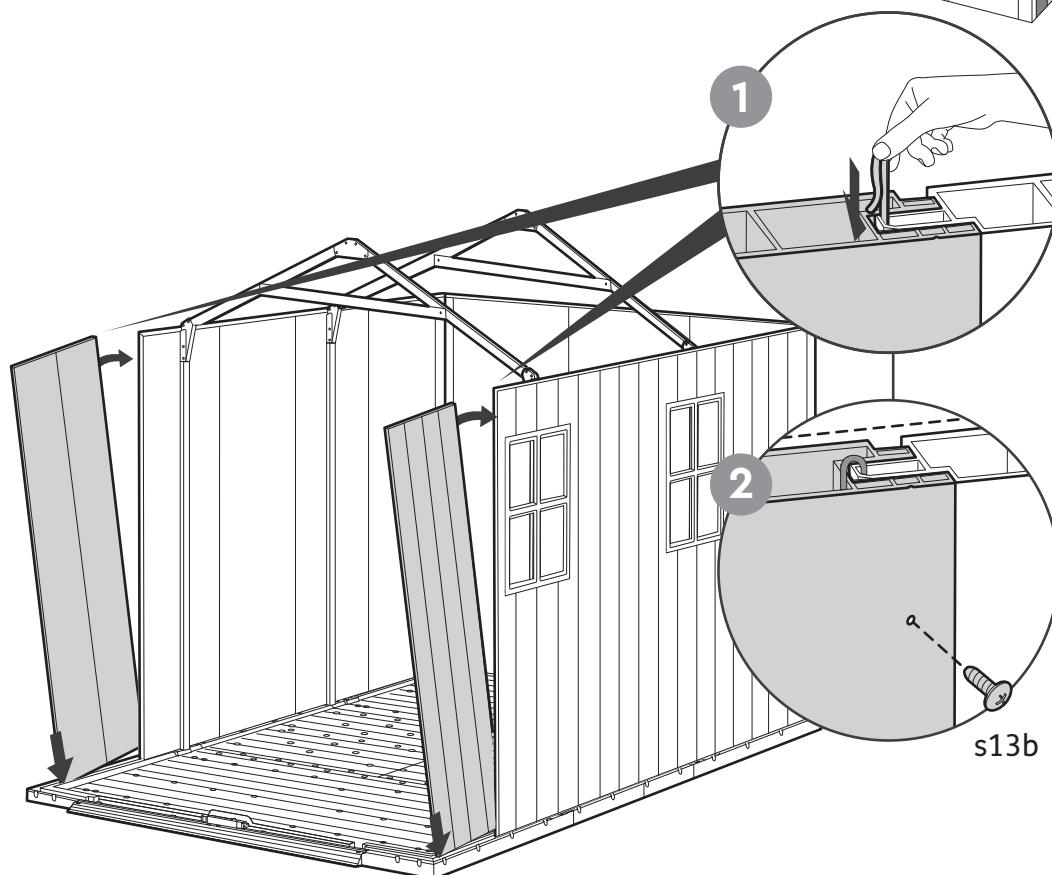
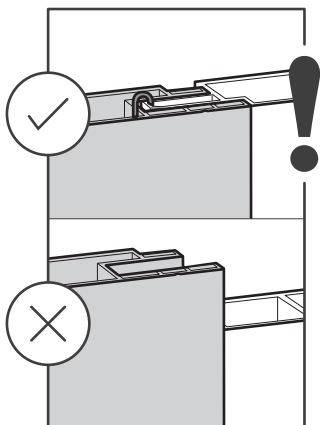
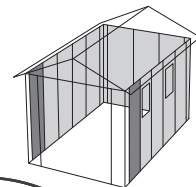

27



NPPC (x2)



KP (x2)

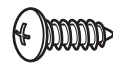

s13b (x2)

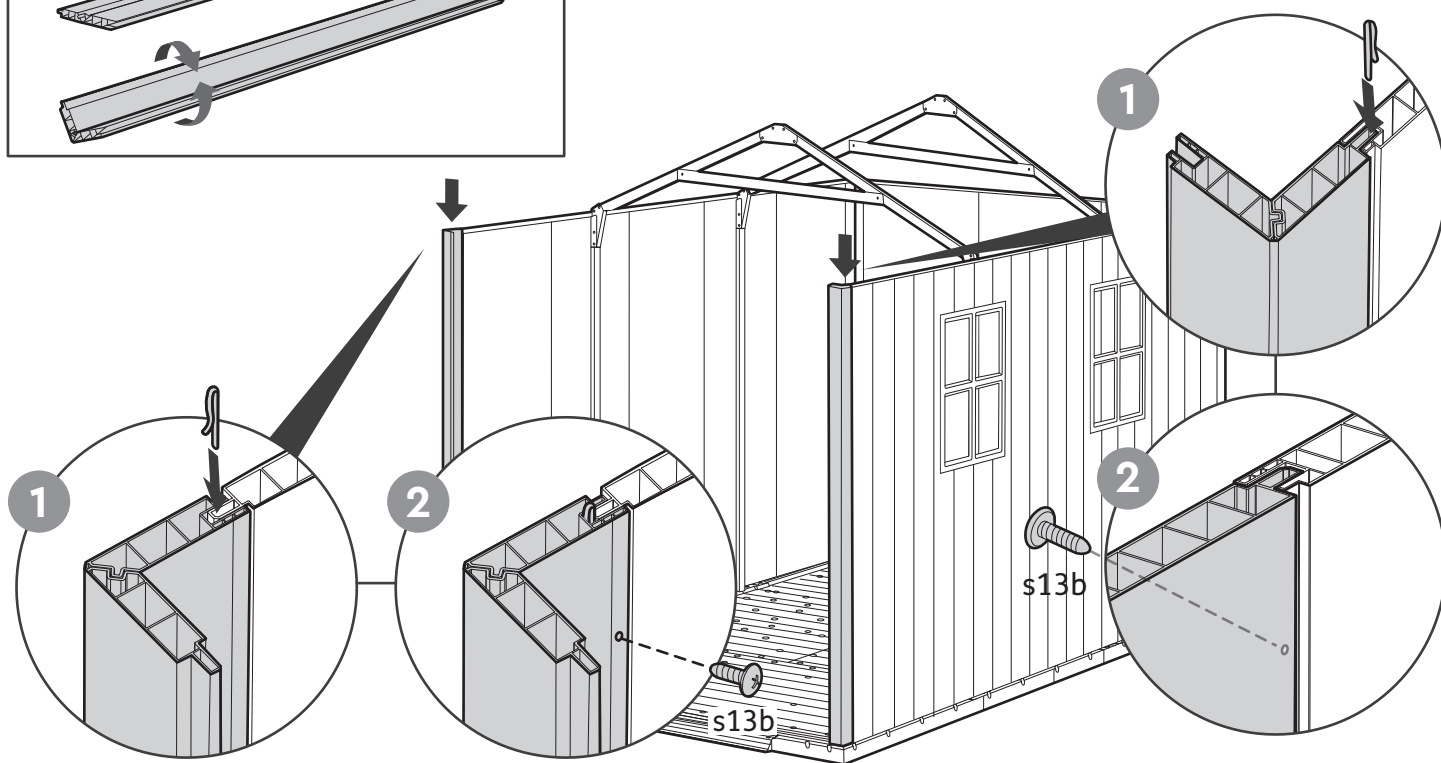
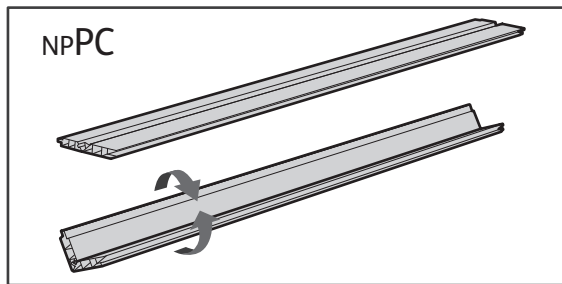
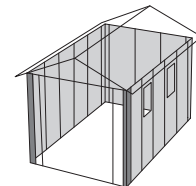

28

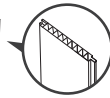
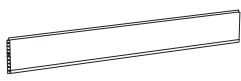

NPFF (x2)

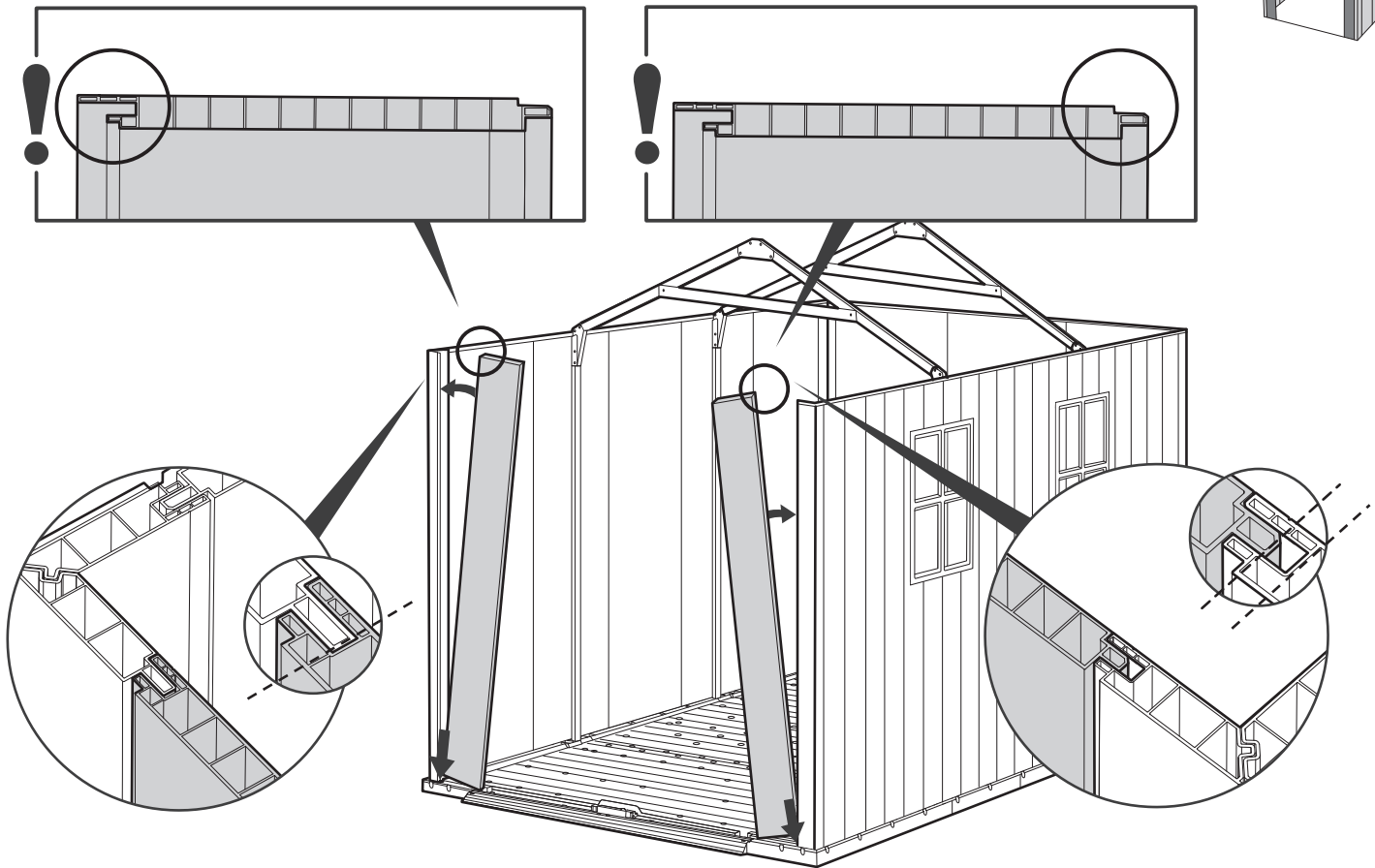
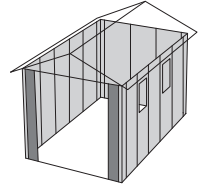

29



s13b (x6)

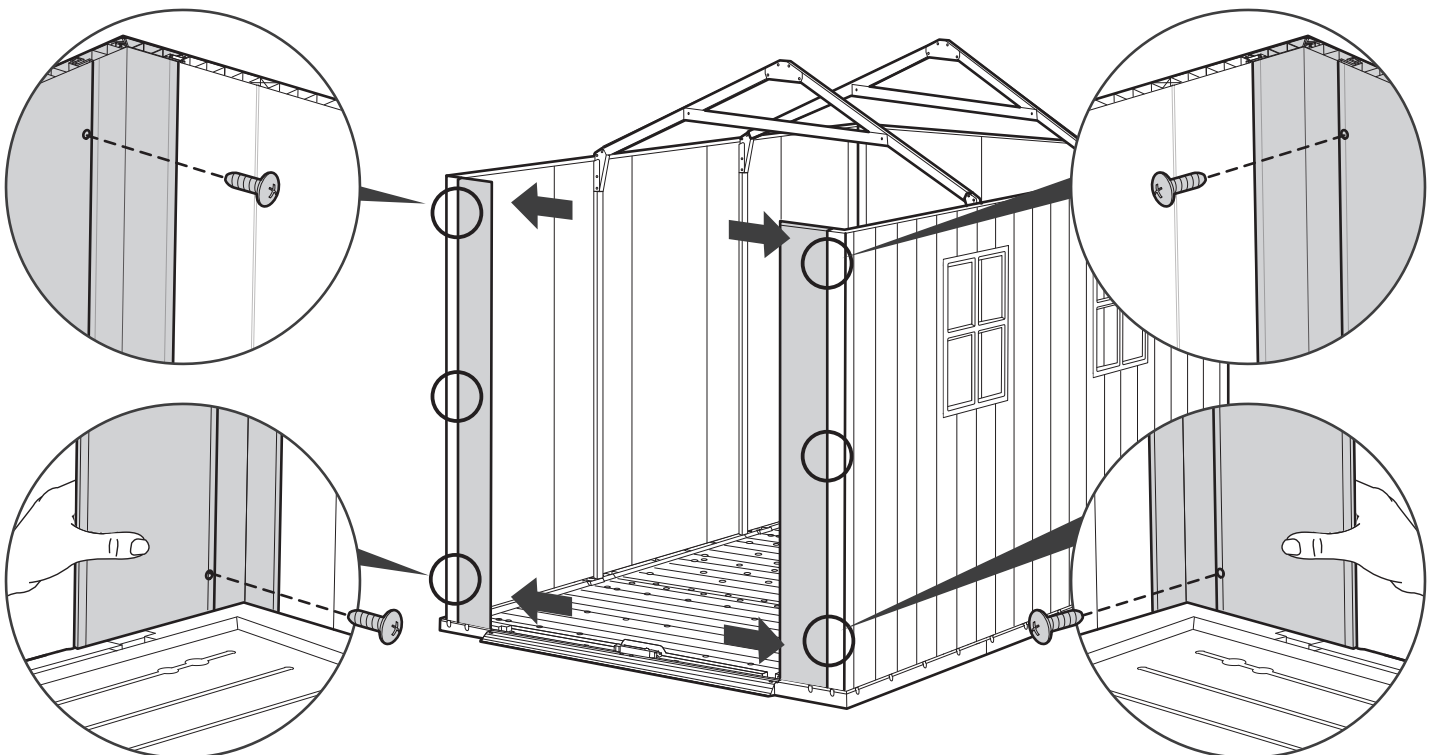
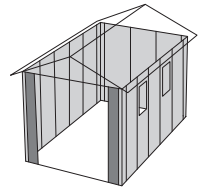

30

 S45b (x36)

 sdLIN (x2)

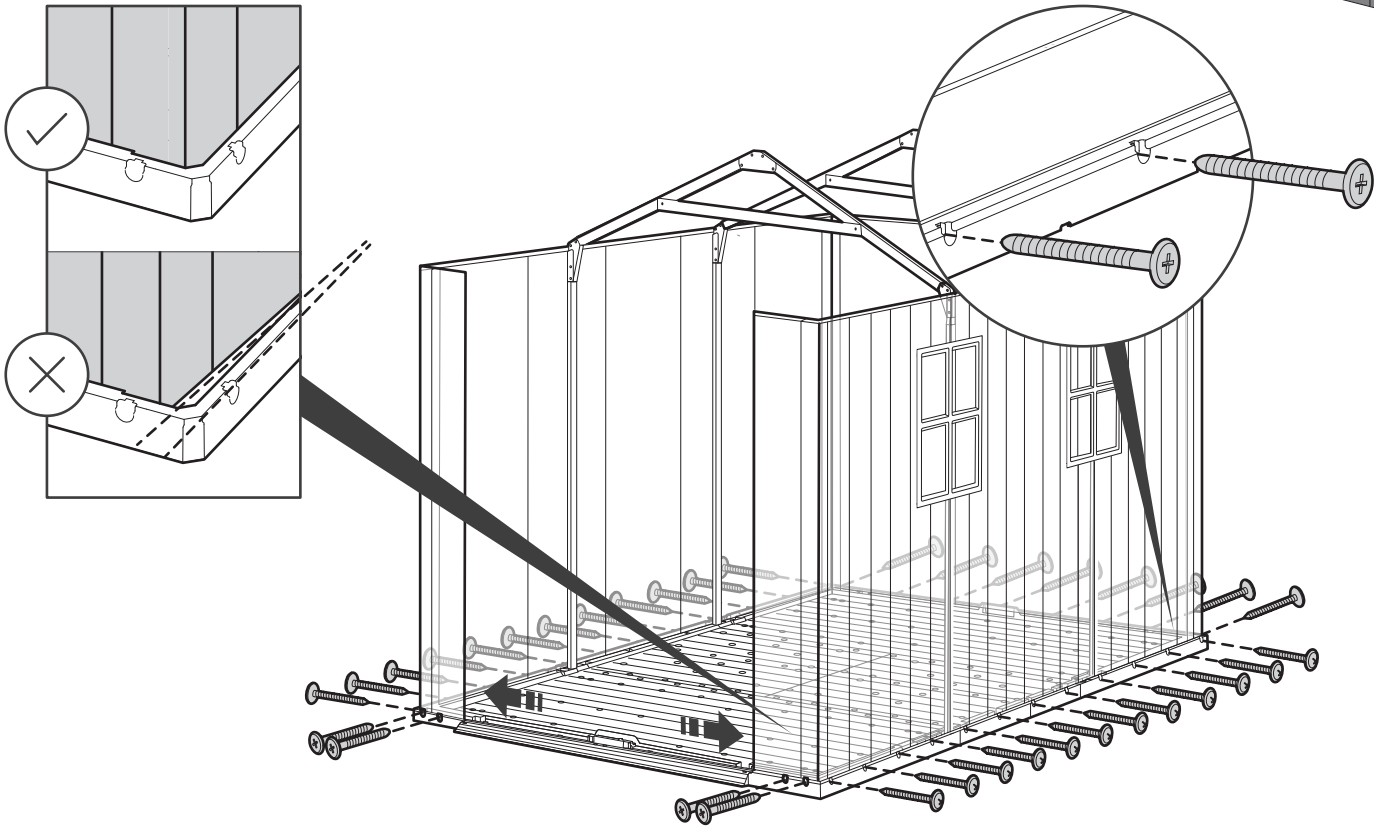
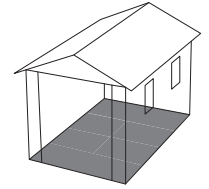

31

 NPLDF (x1)

 NPRDF (x1)

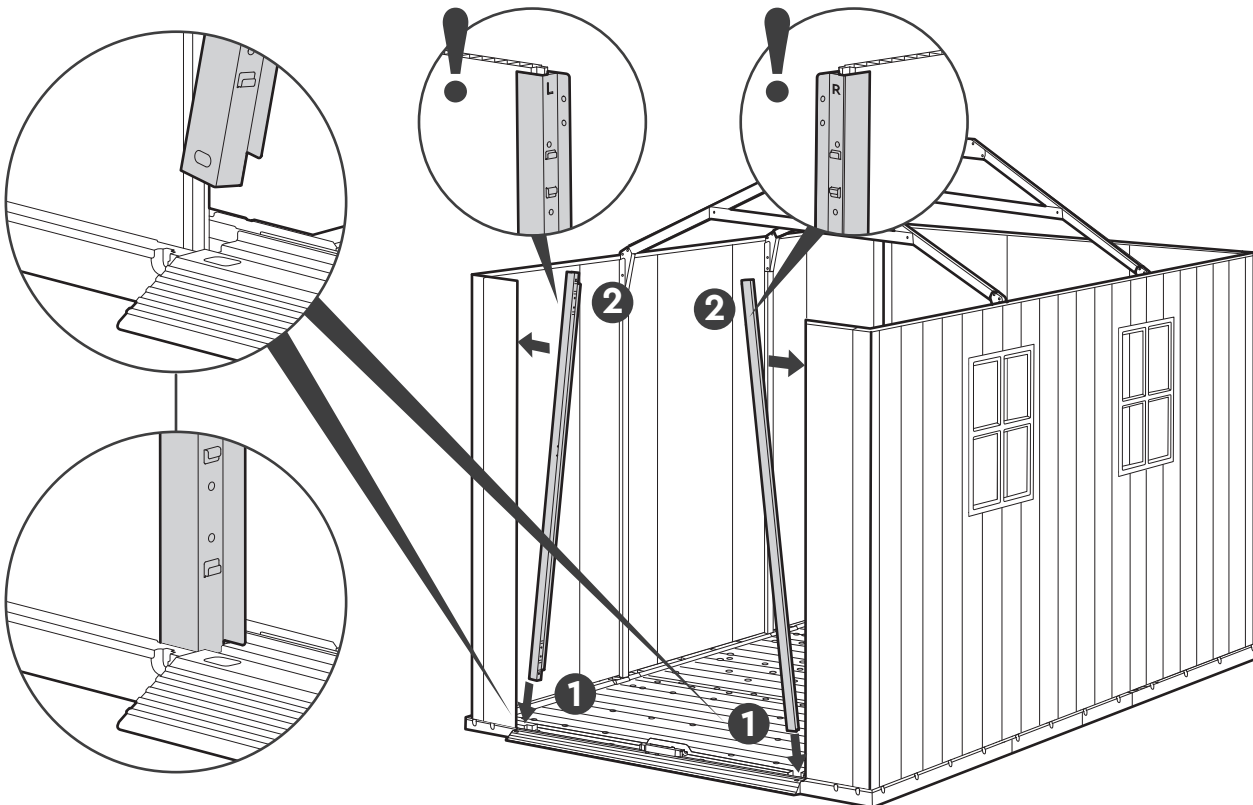
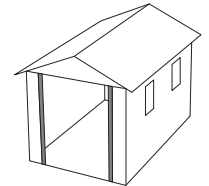

32

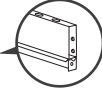

NPUDF (x1)



sc7t (x2)

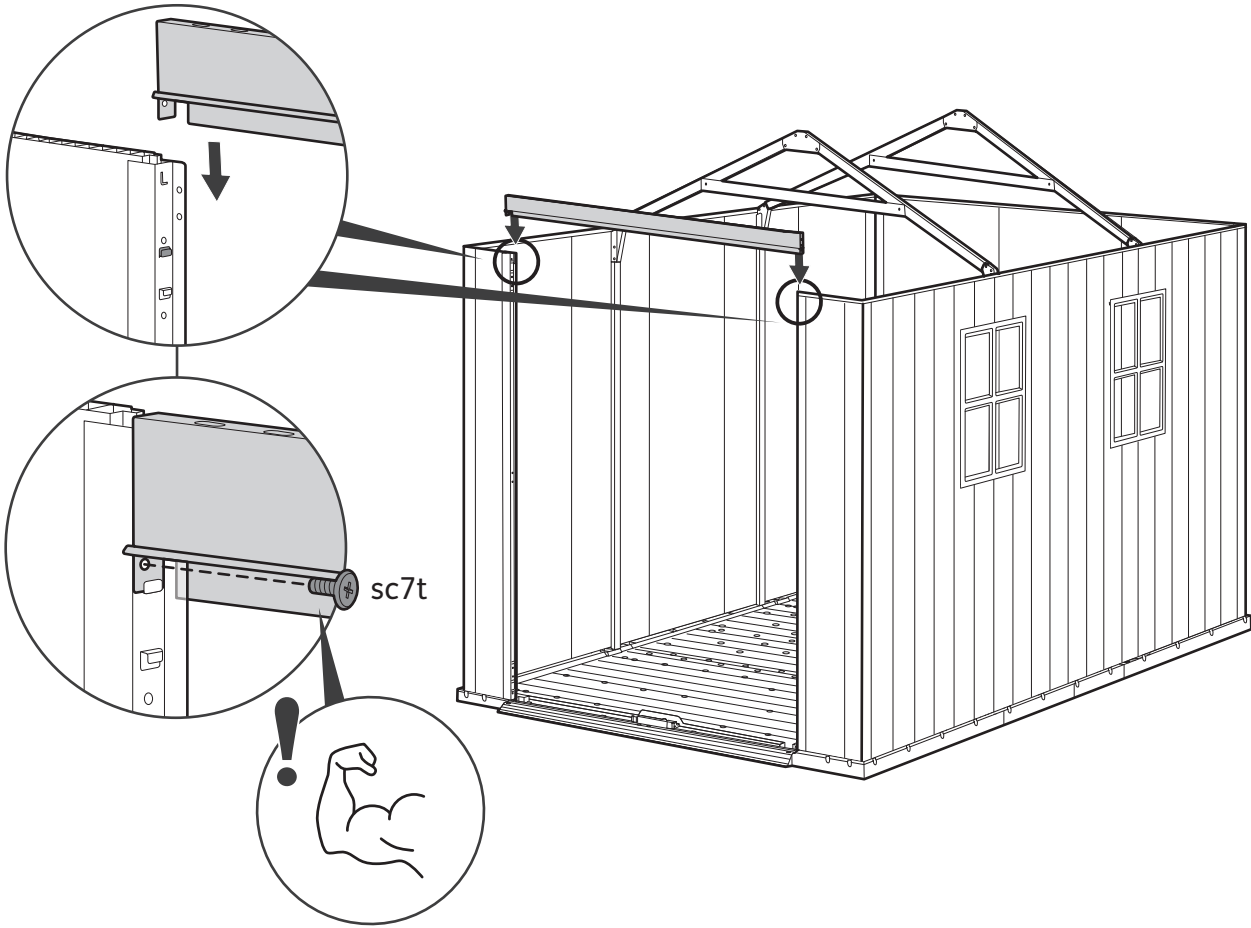
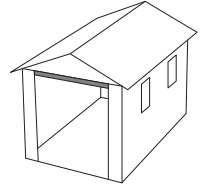

33

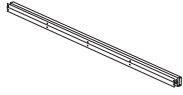

NPCL (x2)

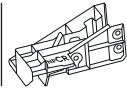

NPCR (x2)

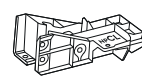

NPCR (x2)

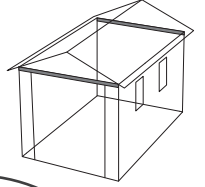

1

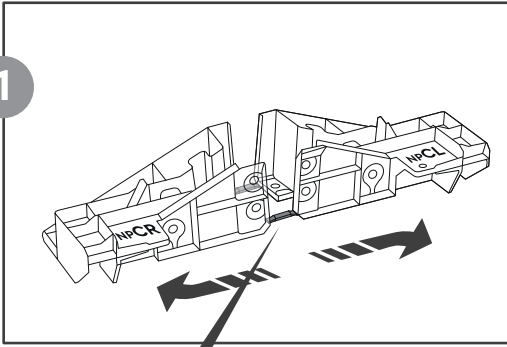

2

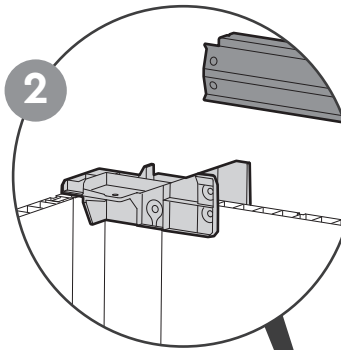

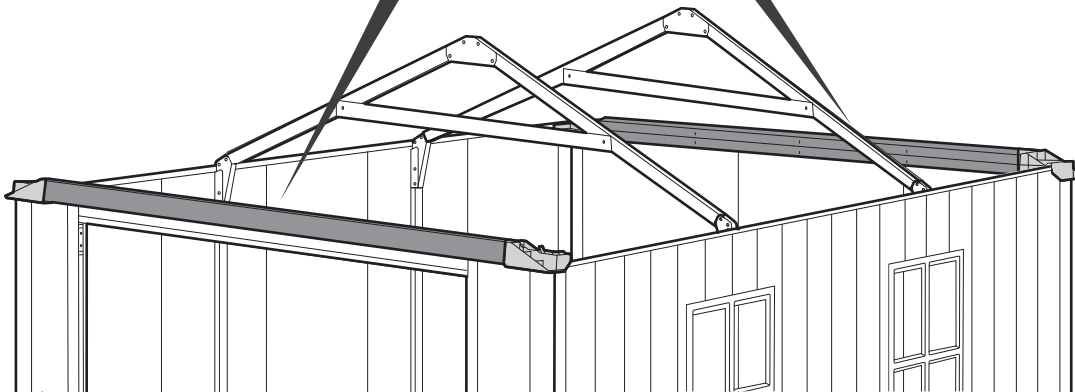
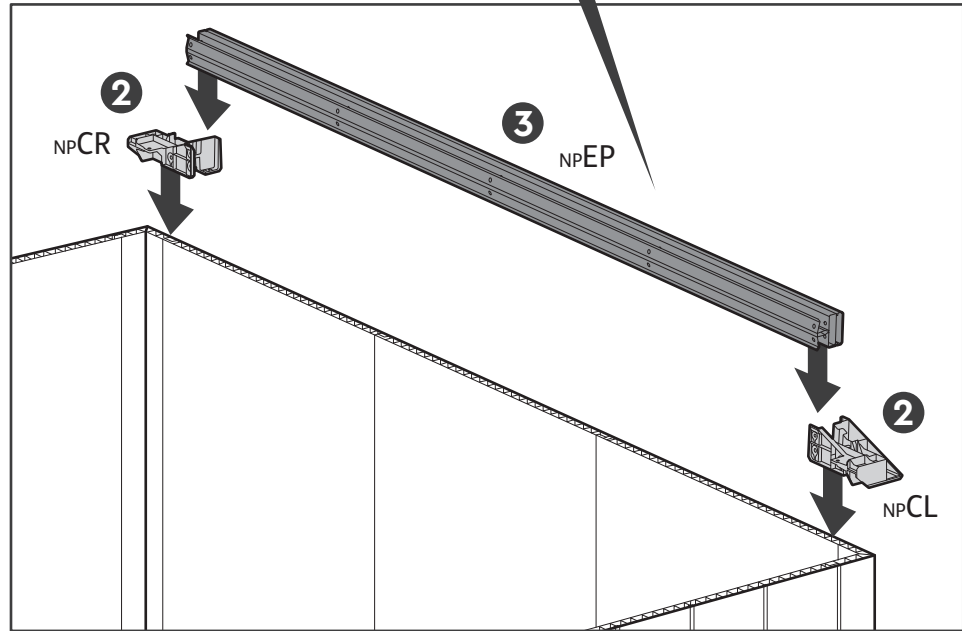
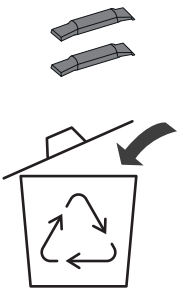
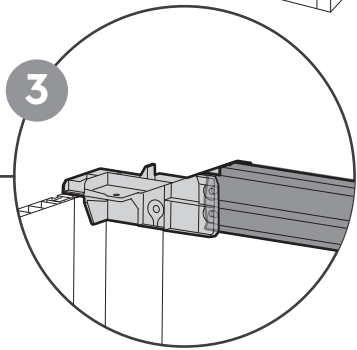

3

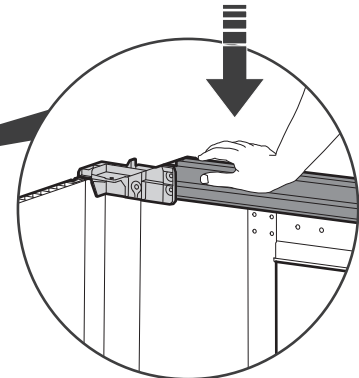
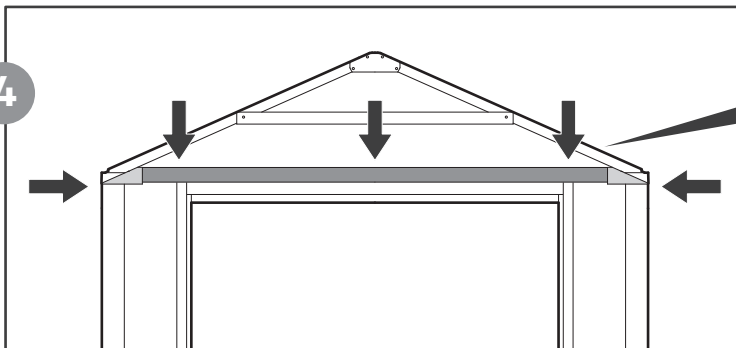

4

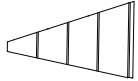
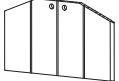
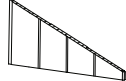
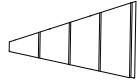
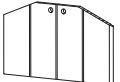
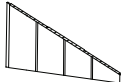

**ROOF ASSEMBLY | MONTAGE DU TOIT | MONTAJE DEL TECHO | DACHMONTAGE | DAKMONTAGE | ASSEMBLAGGIO DEL TETTO | MONTAGEM DO TELHADO**

- |           |   |   |  |   |
|-----------|---|---|--|---|
| <b>34</b> |  NPZ3 (x1) |  NPZ2 (x1) |  NPZ1 (x1) |  NPZ6 (x1) |
|           |  NPZ5 (x1) |  NPZ4 (x1) |  s13b (x8)  |   |

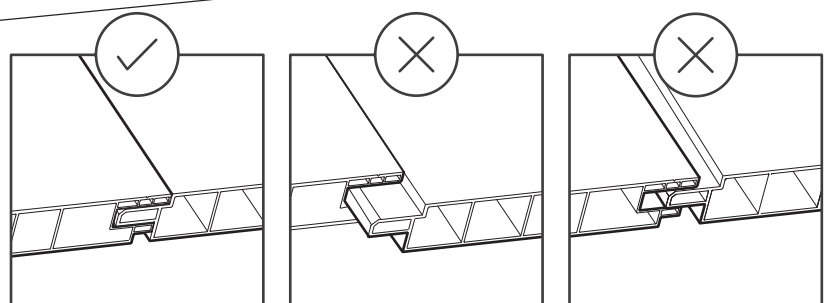
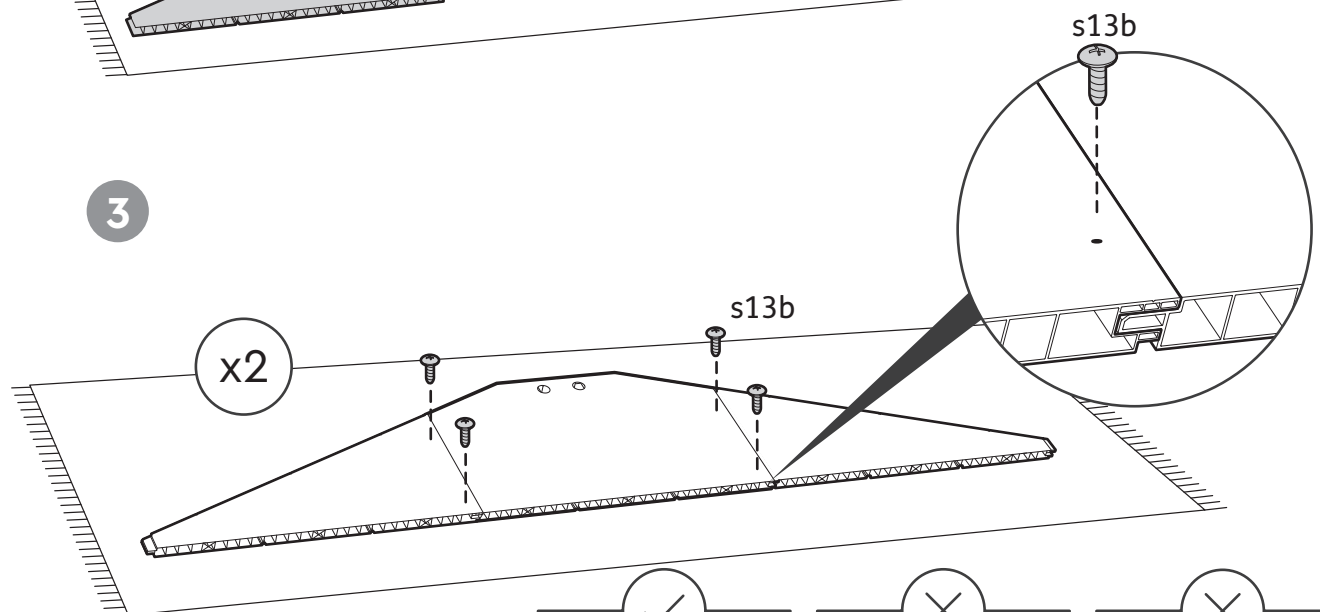
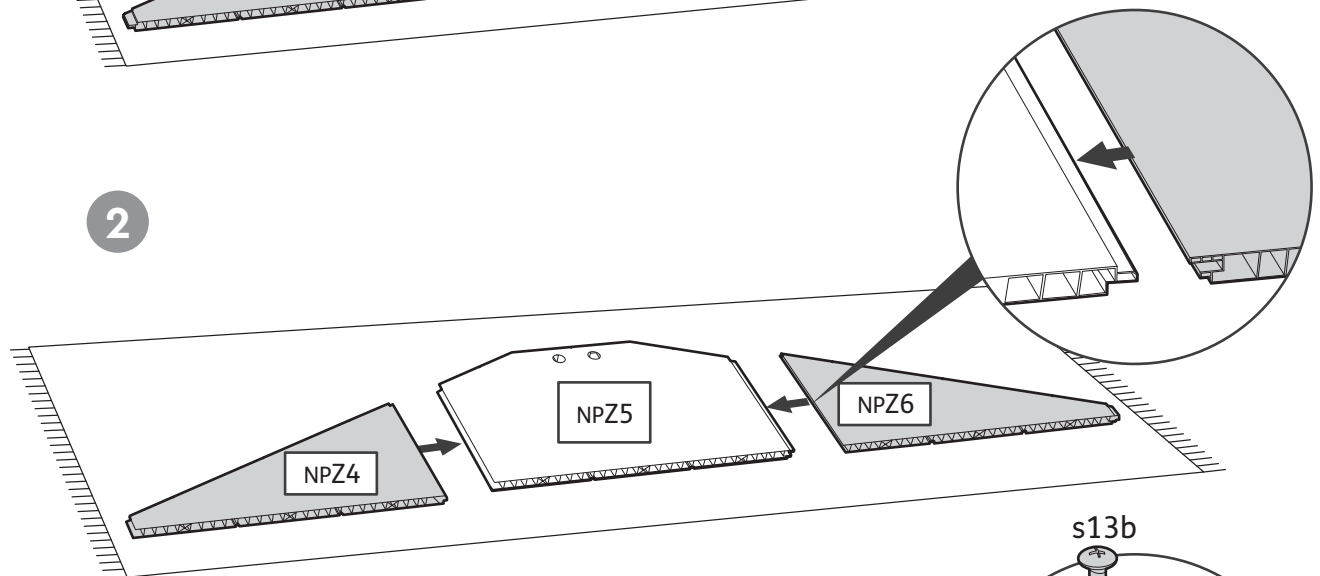
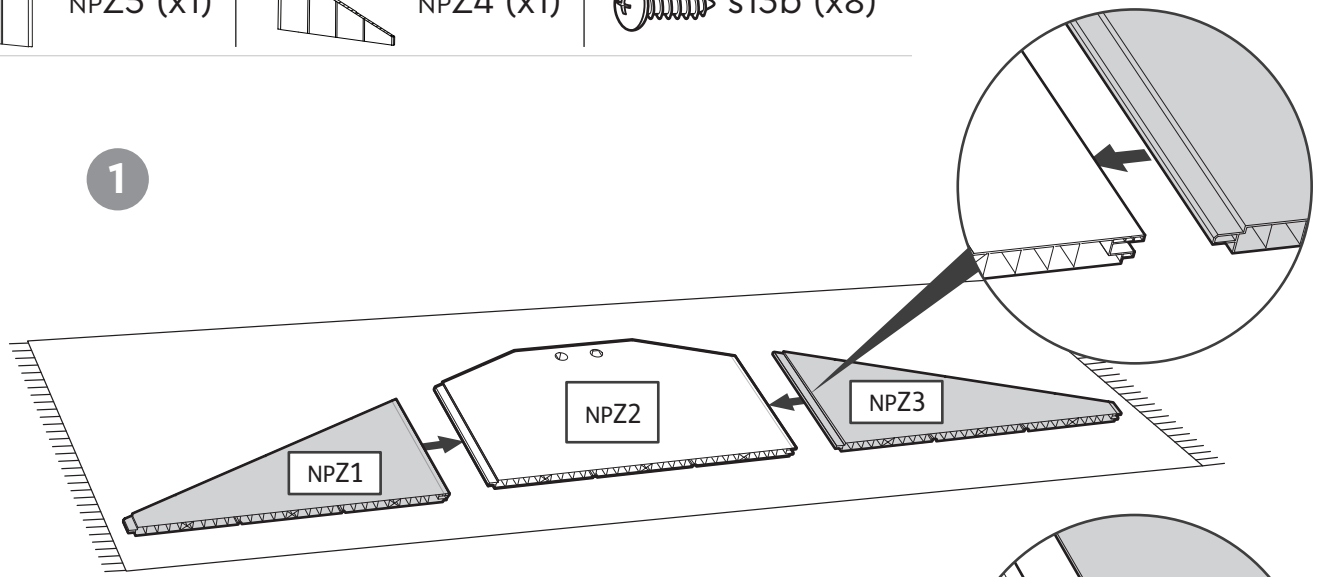

35

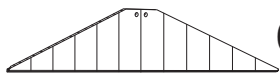

(x2)



moAK (x2)

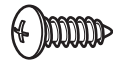

s13b (x2)

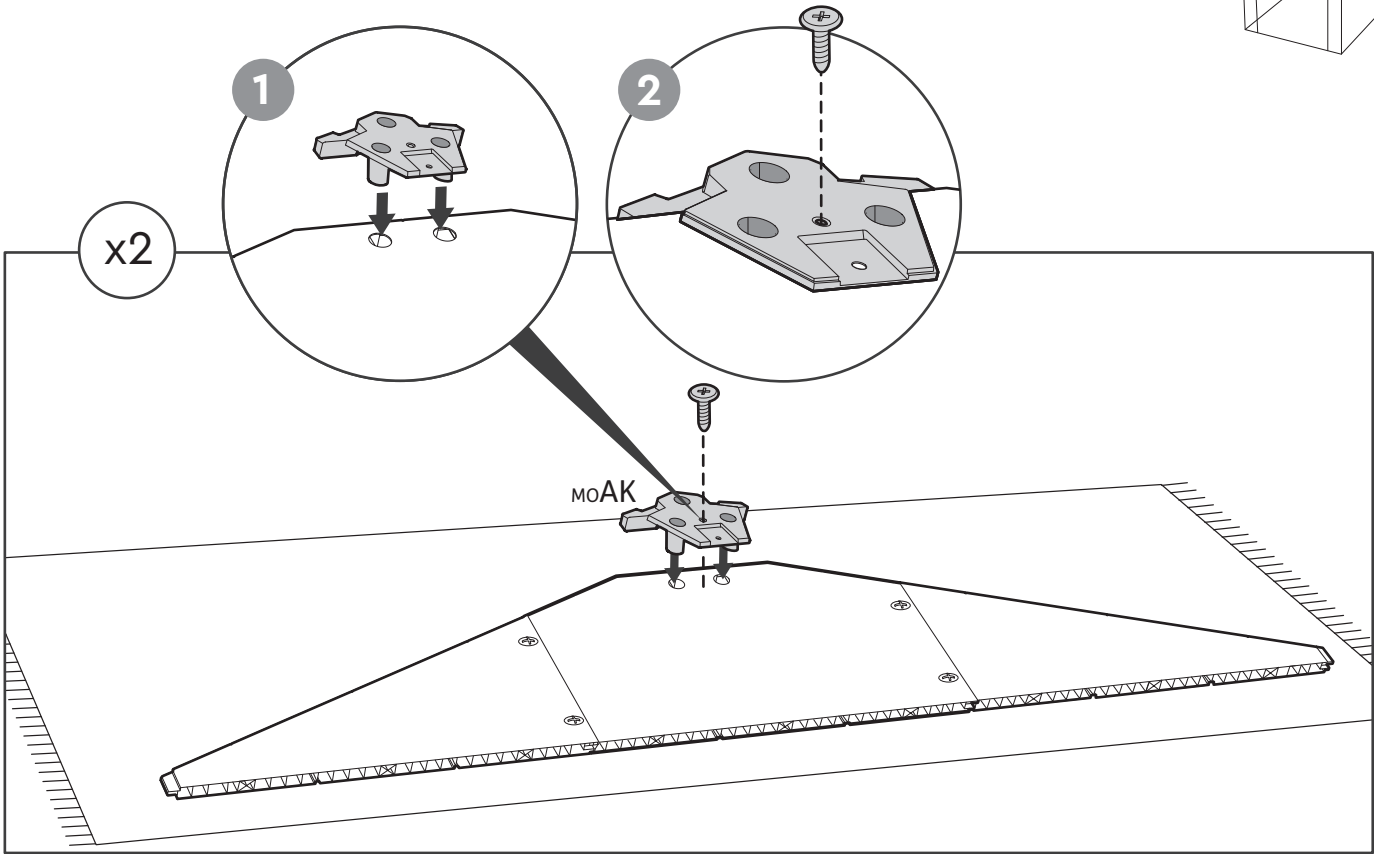
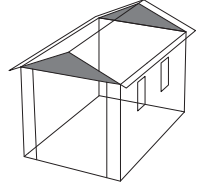

36

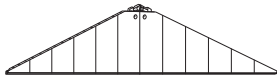

(x1)

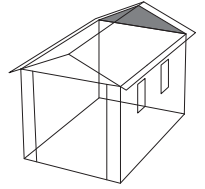

Outside | Extérieure | Exterior | Außenseite |  
Buitenkant | Esterno | Exterior

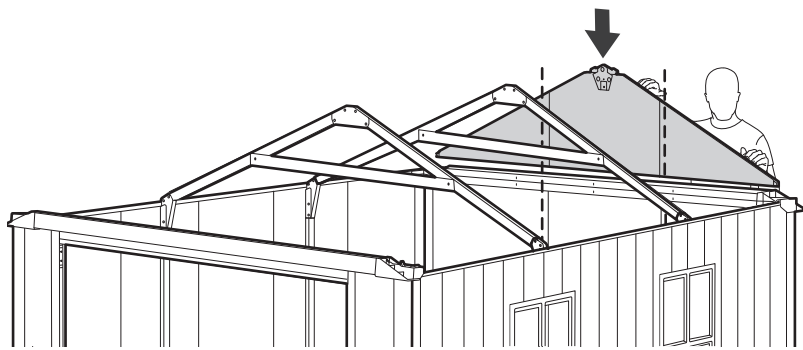
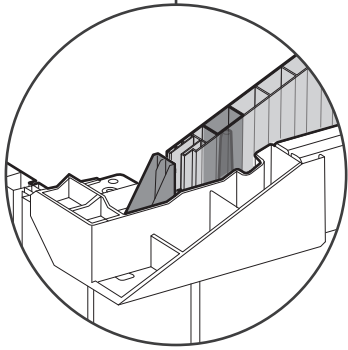
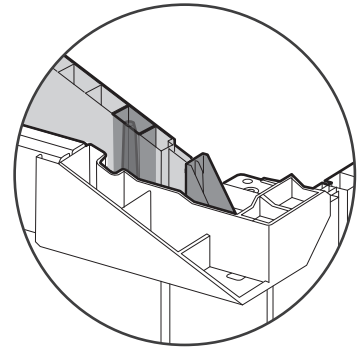
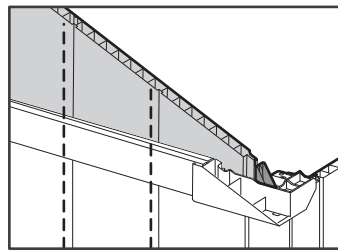
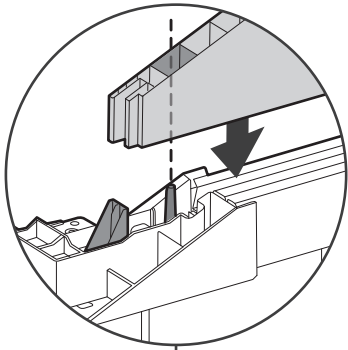

37

sc15 (x12)

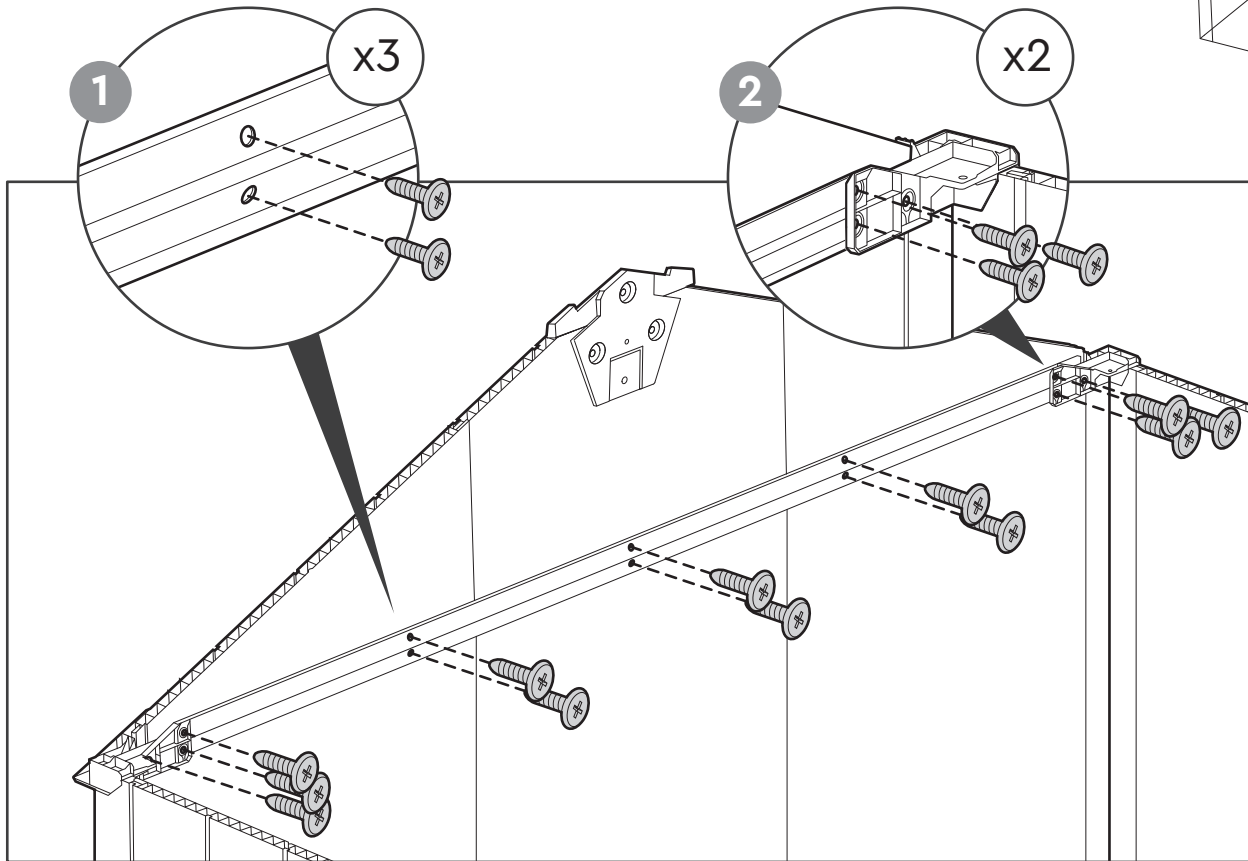
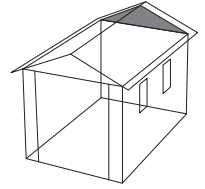

38

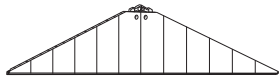

(x1)

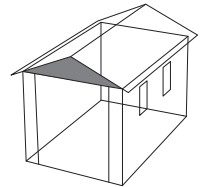

Outside | Extérieure | Exterior | Außenseite |  
Buitenkant | Esterno | Exterior

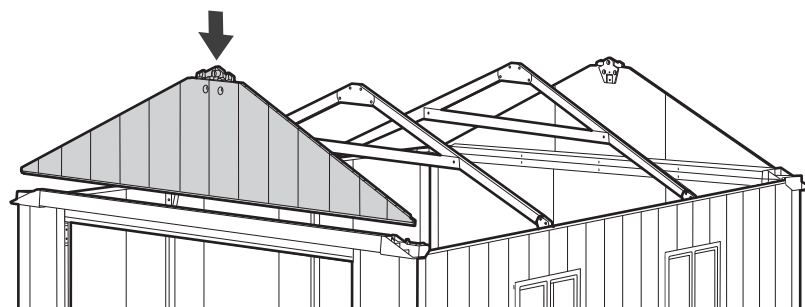
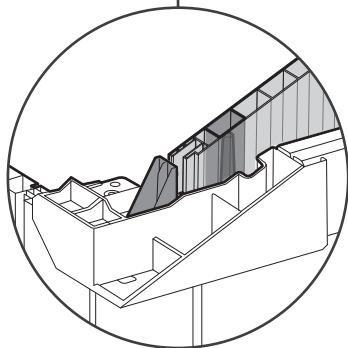
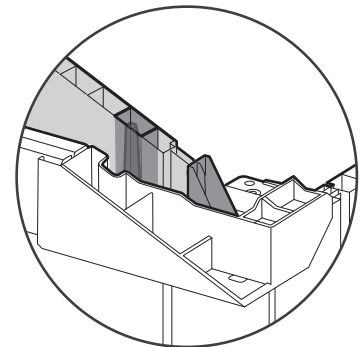
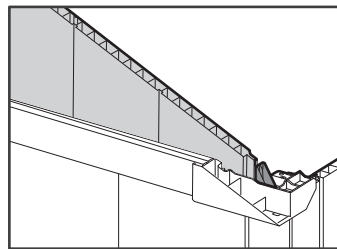
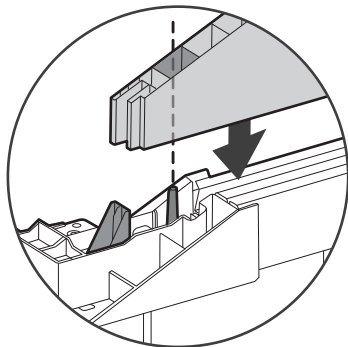

39

sc15 (x6)

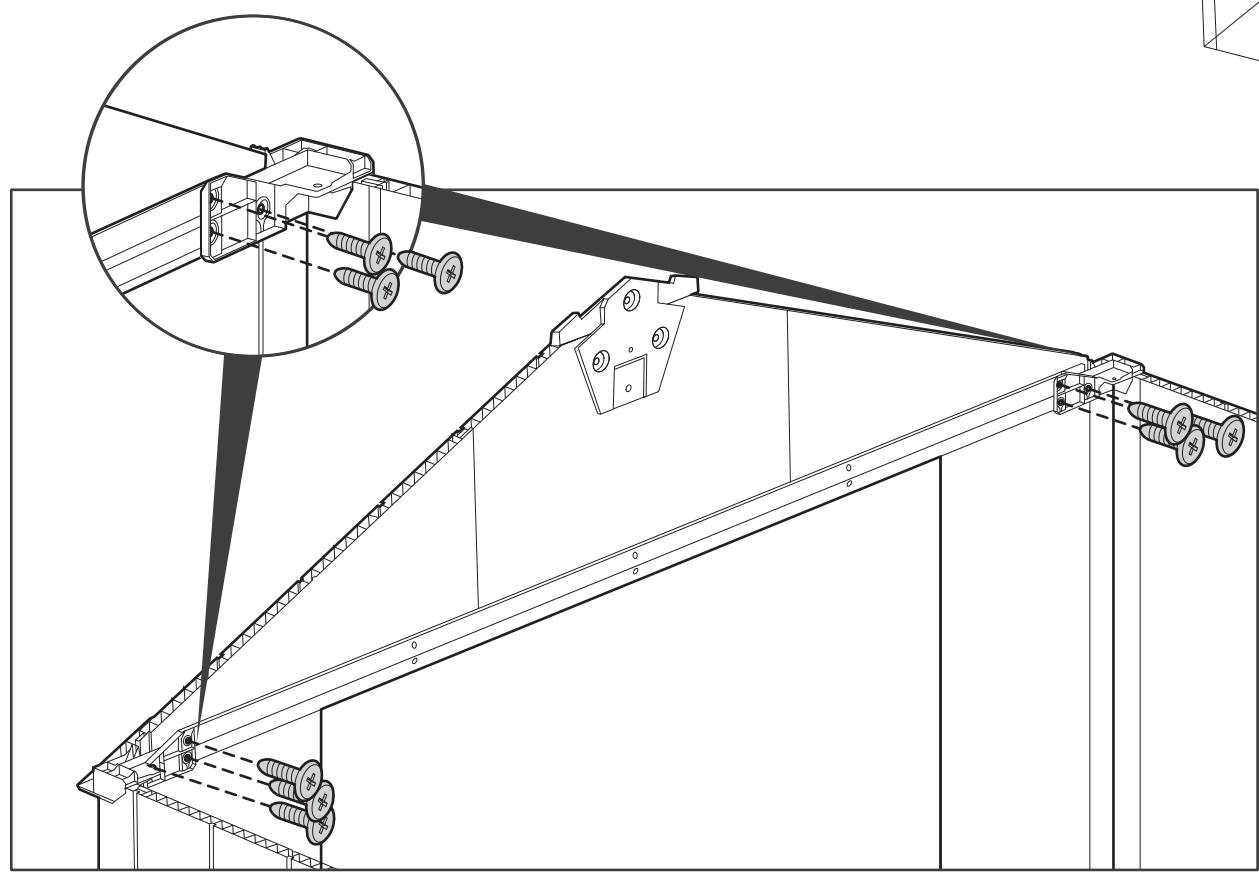
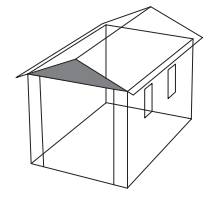

40



NPMP (x1)

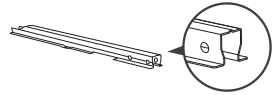

NP5M (x1)

sc8 (x2)

scn8 (x2)

NP5M (x1)

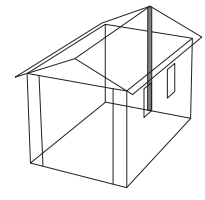

1

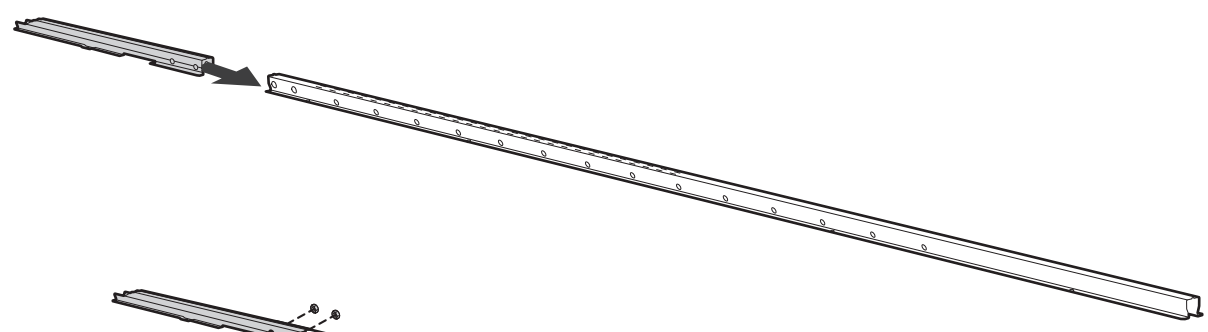

2

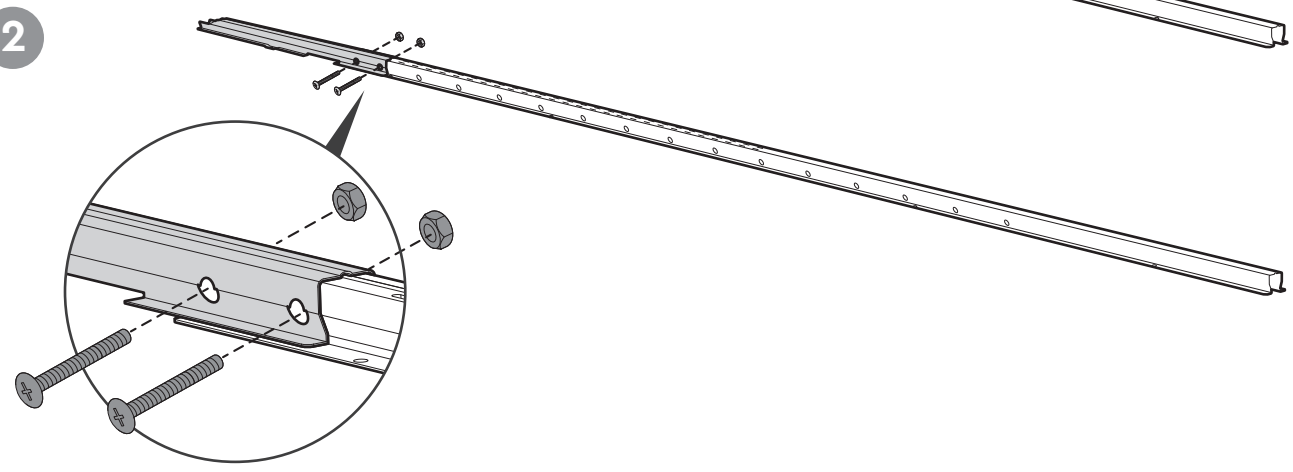

41



NPMP+NP SM (x1)



sc15 (x1)

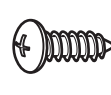

s13b (x10)

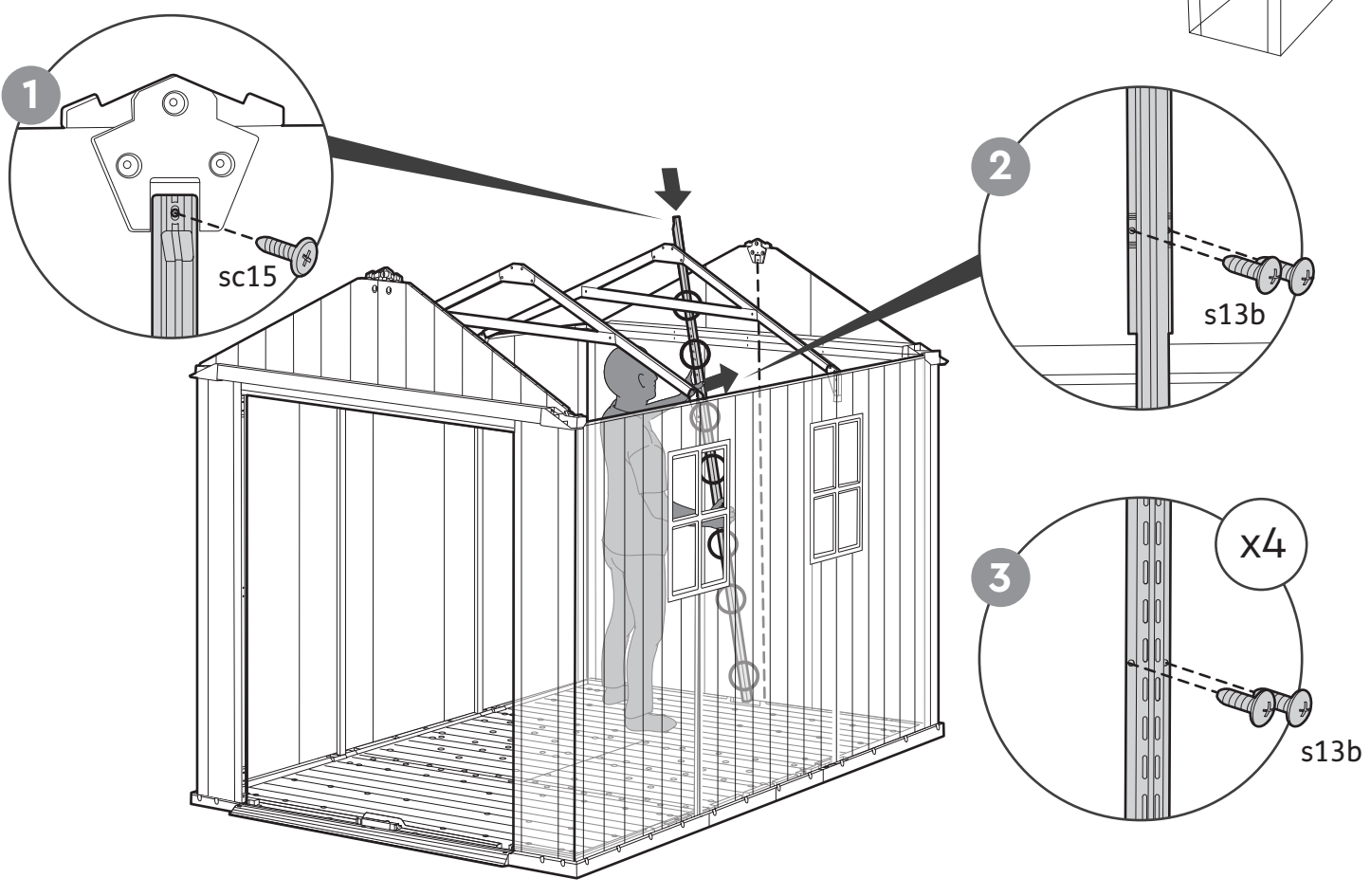
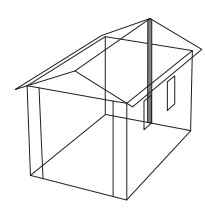

42

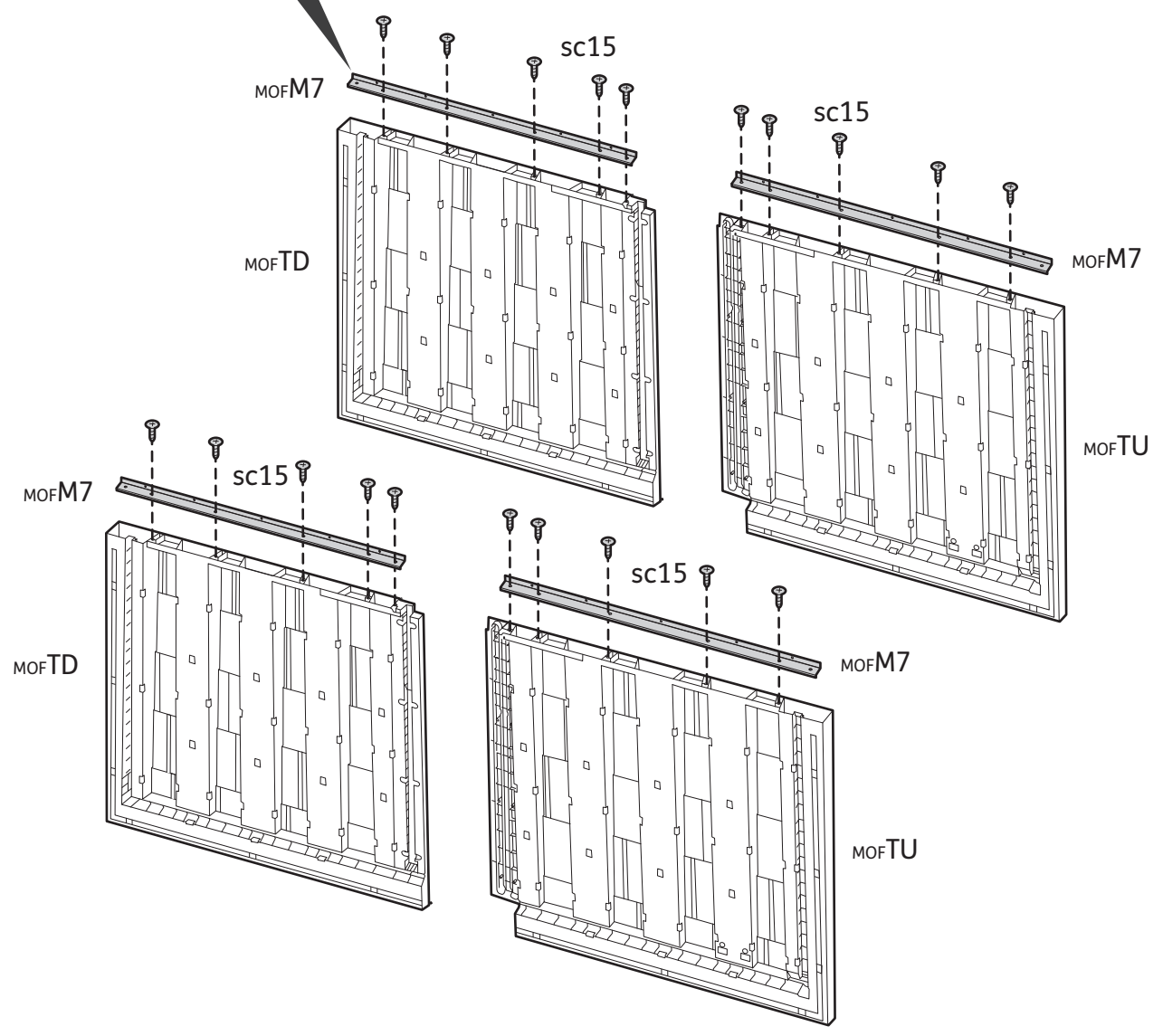
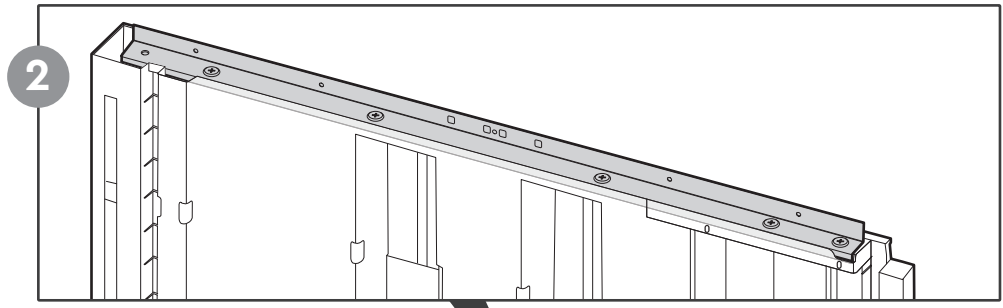
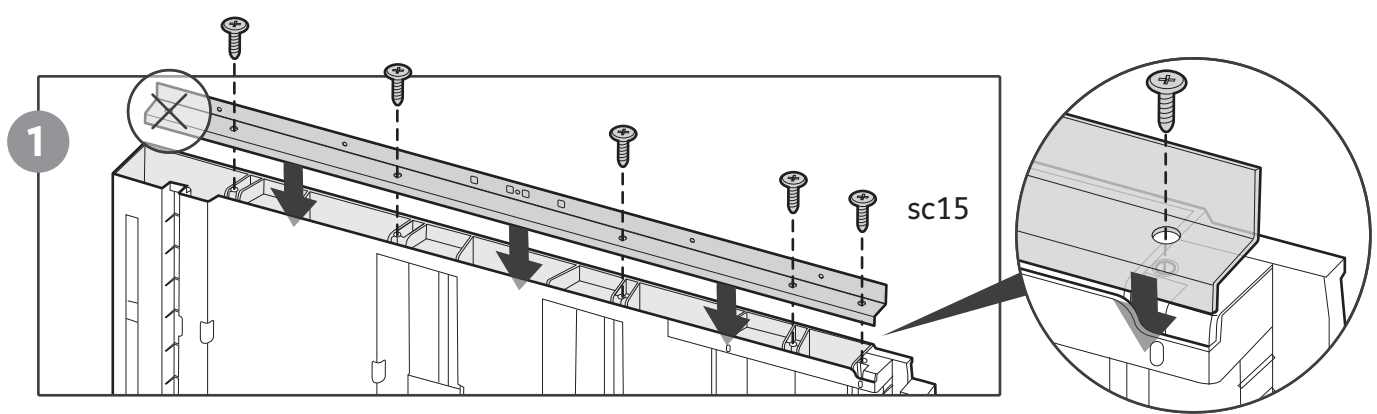
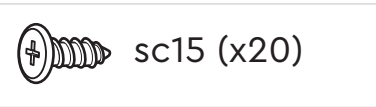
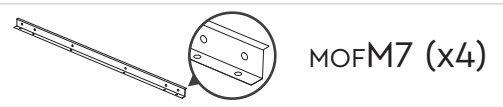
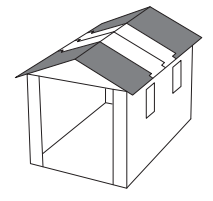

43



MOFT9 (x4)

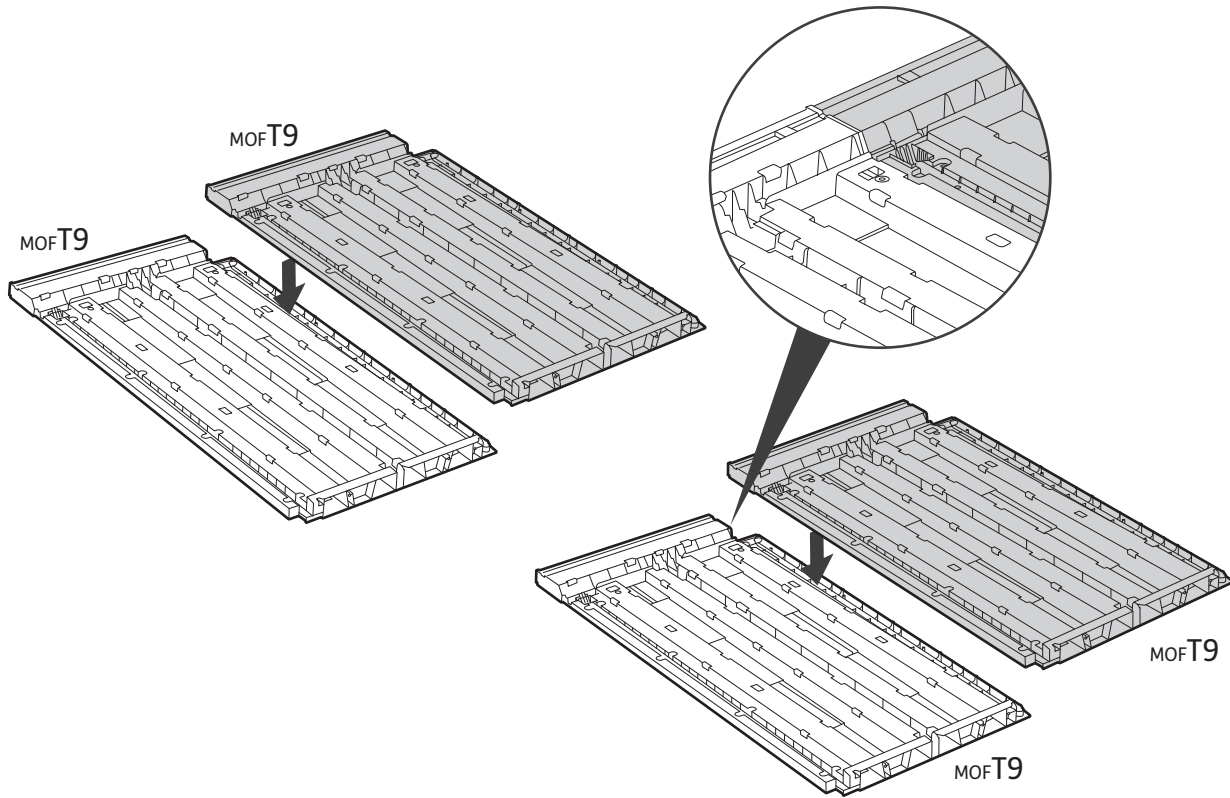
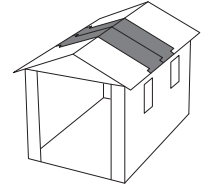

44



(x2)



sc15 (x16)

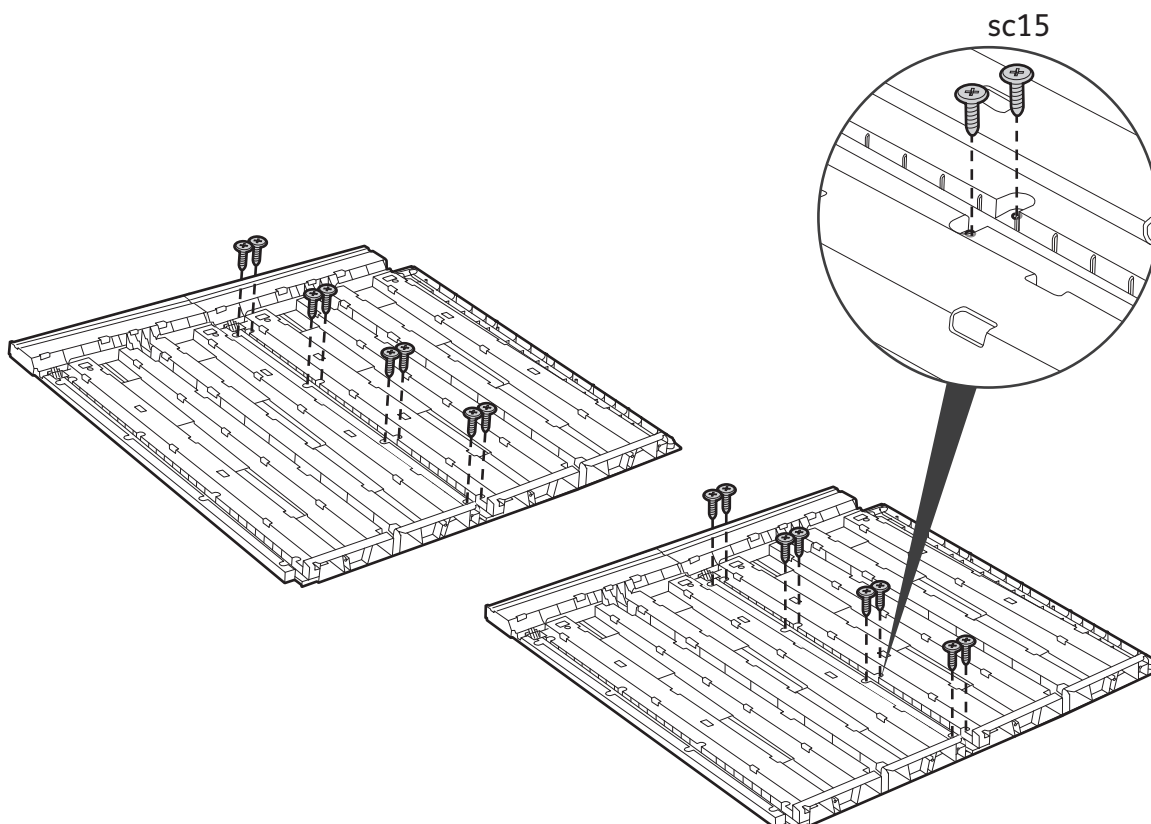
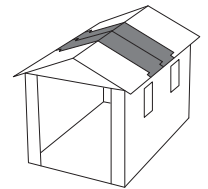

45

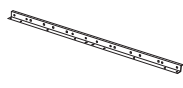

moM11 (x2)



sc15 (x16)

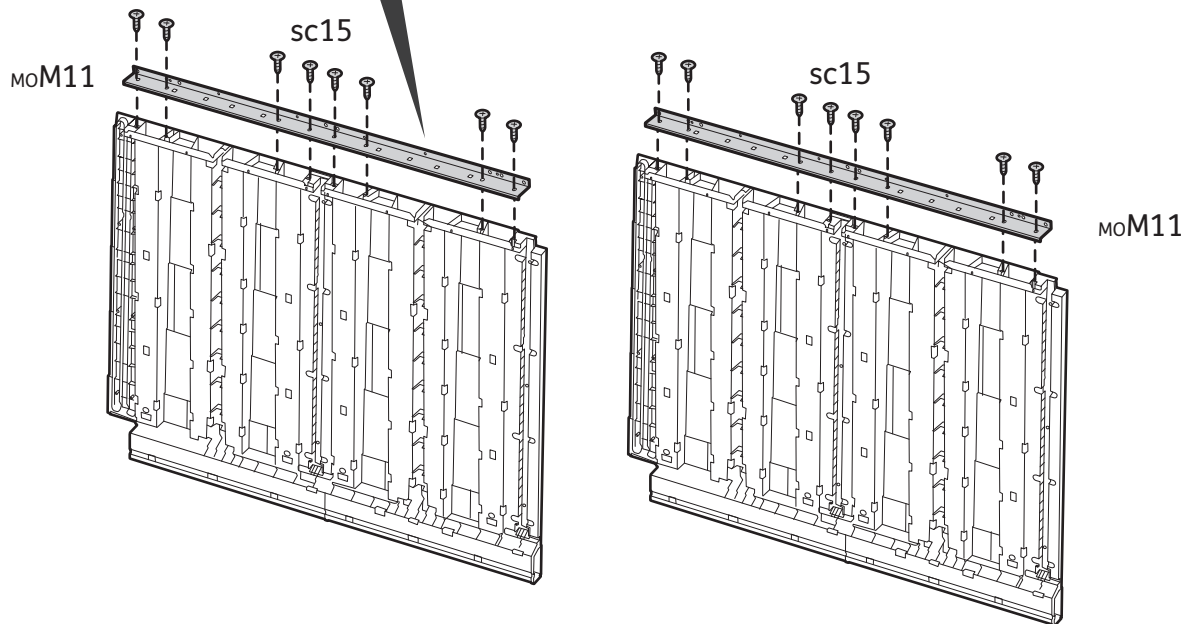
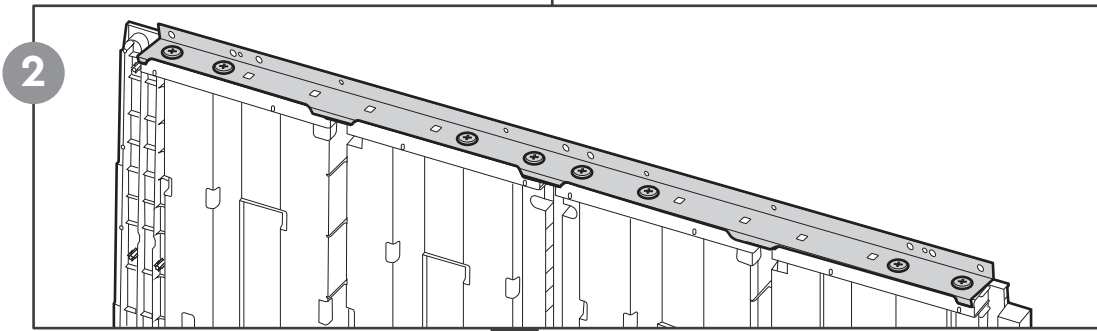
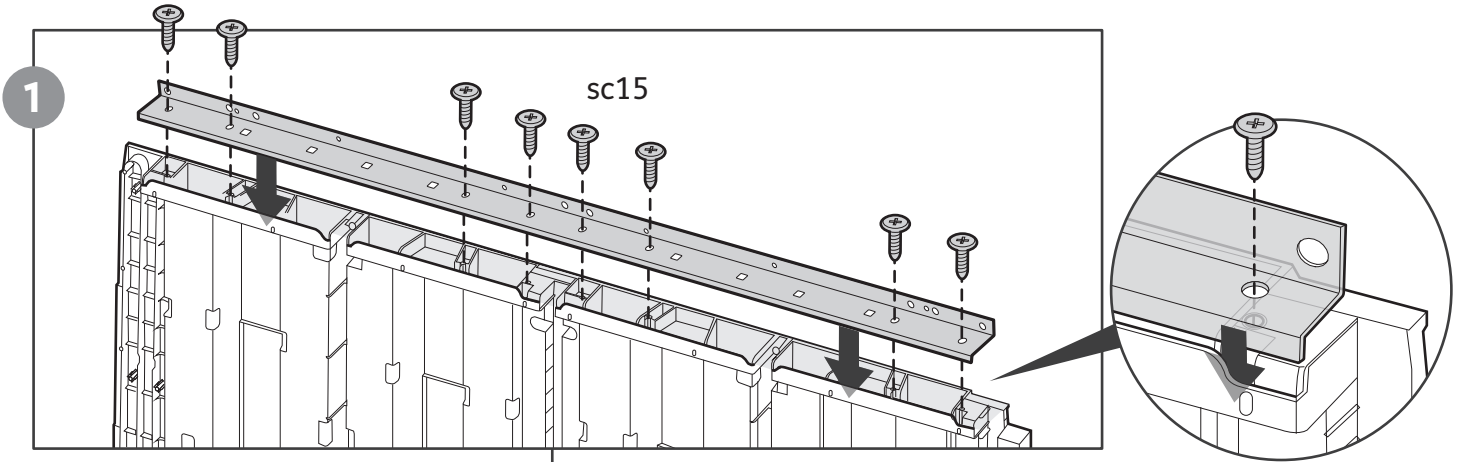
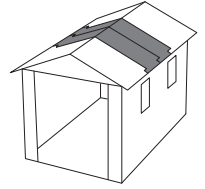

46



MOFTD (x1)

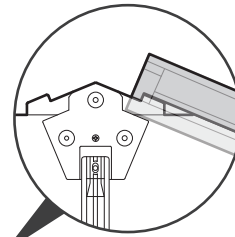
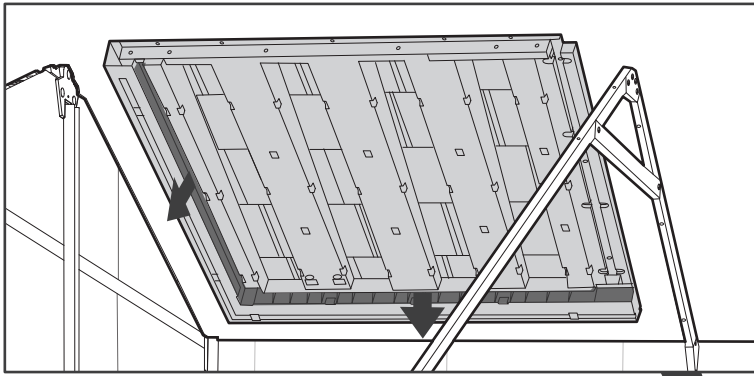
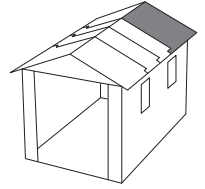

MOFTD

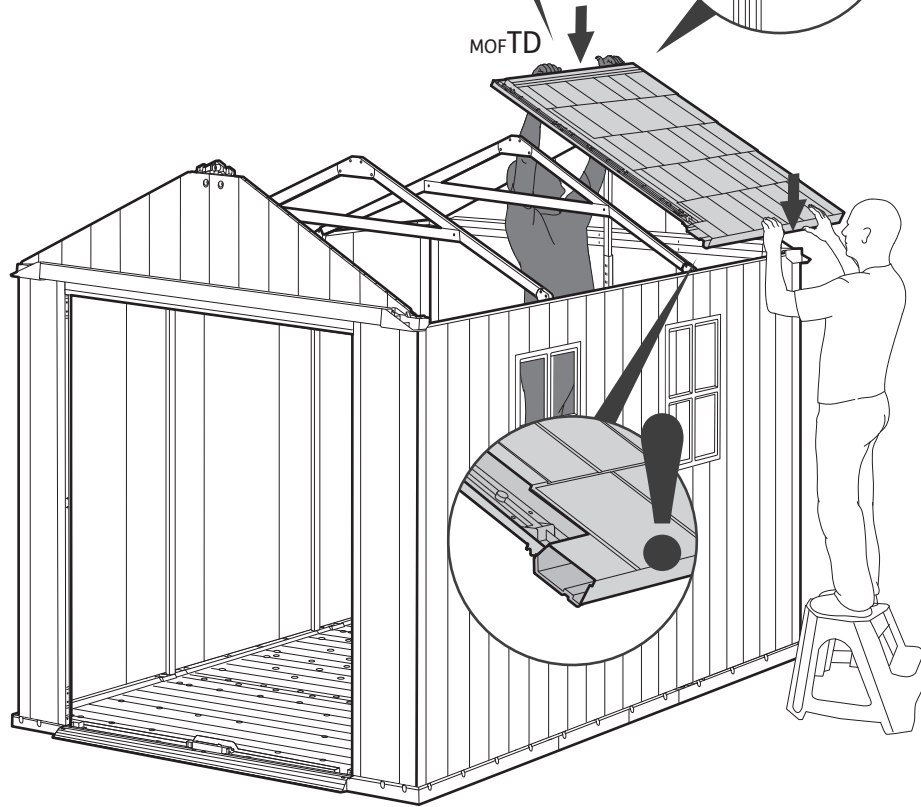

47

 sc15 (x1)

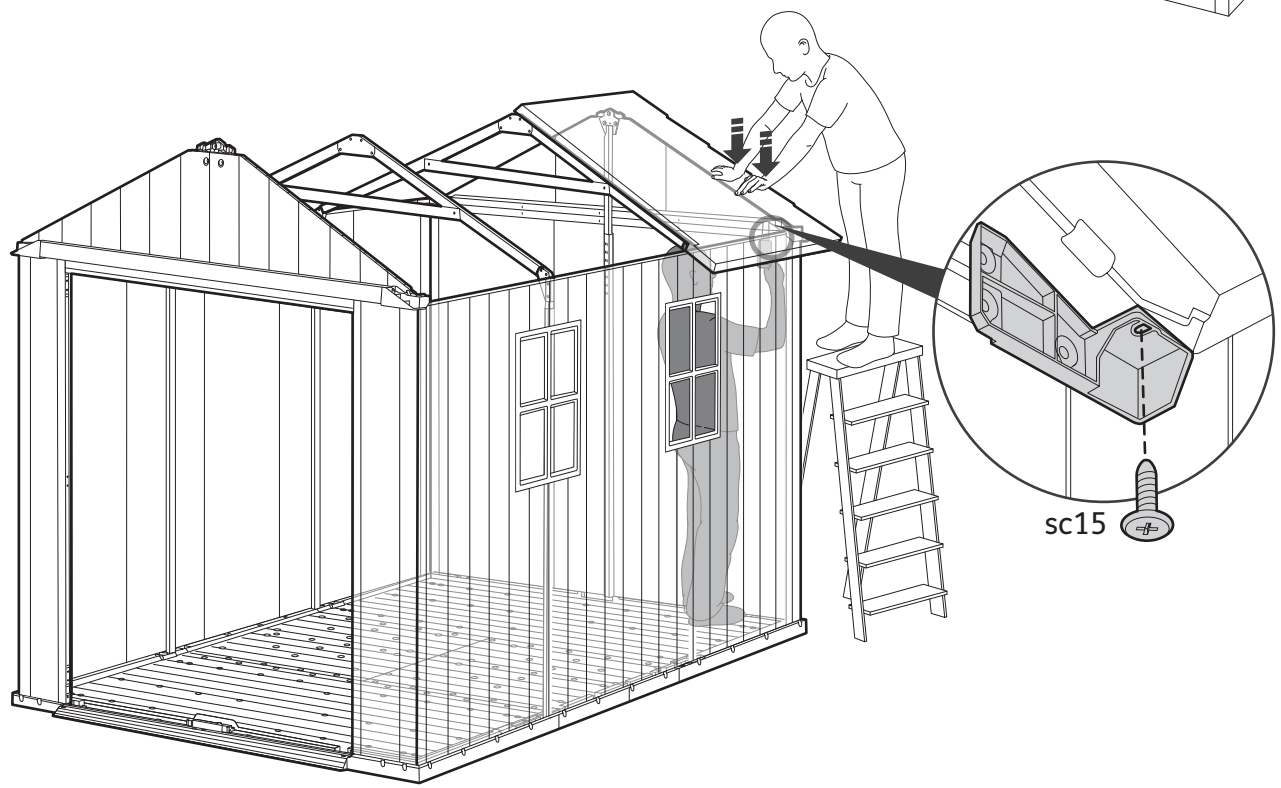
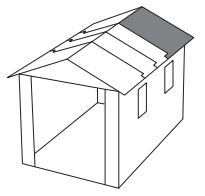

48

 sc15 (x3)

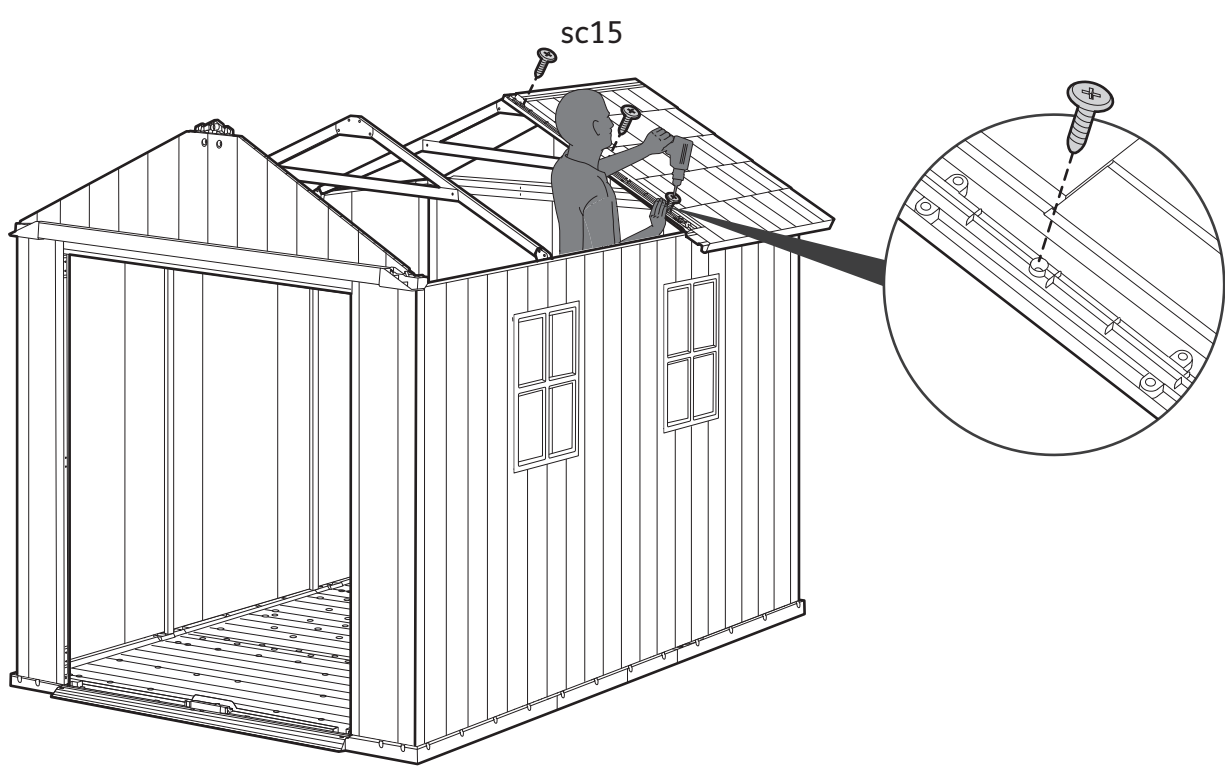
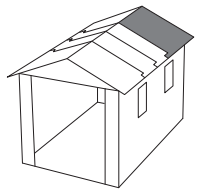

49



MOFT9+ MOFT9 (x1)

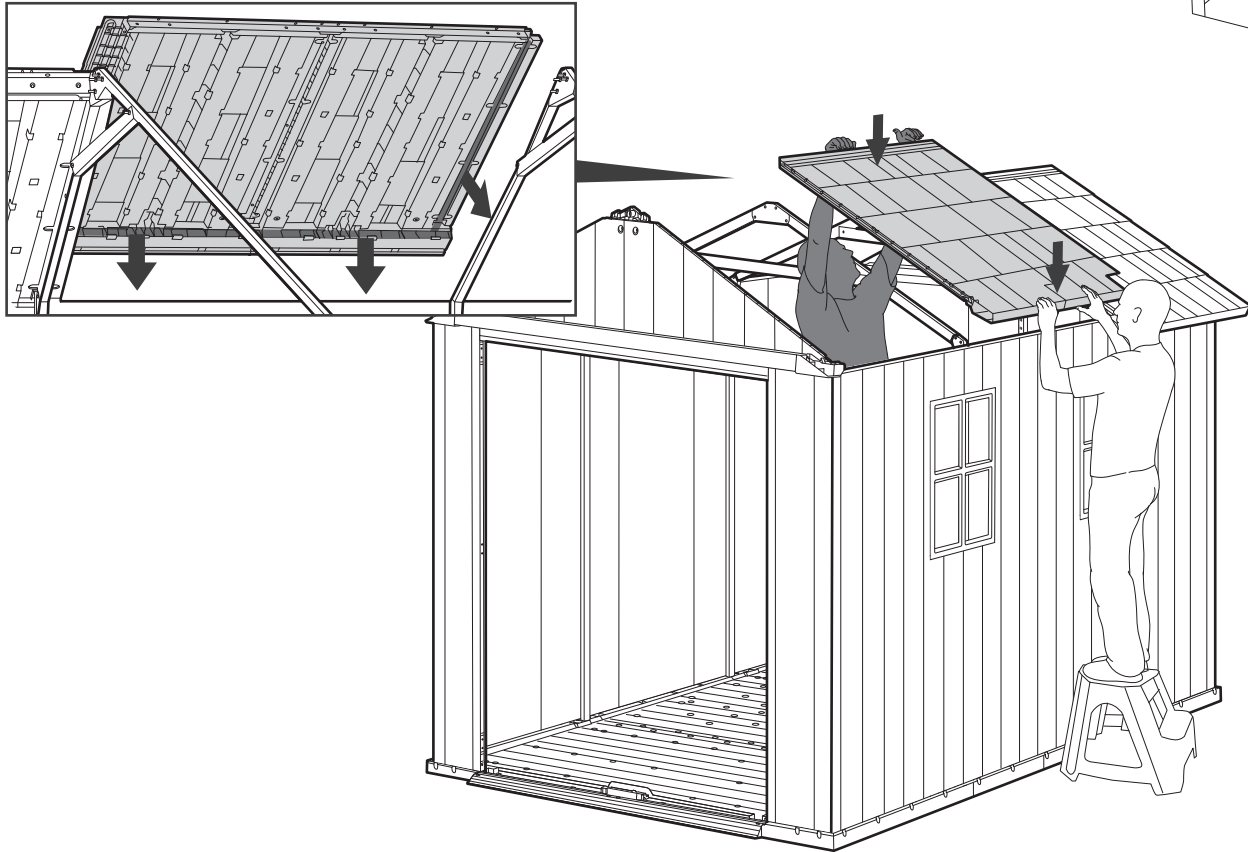
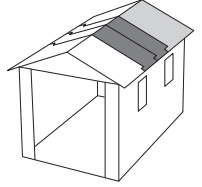

50

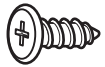

sc15 (x8)

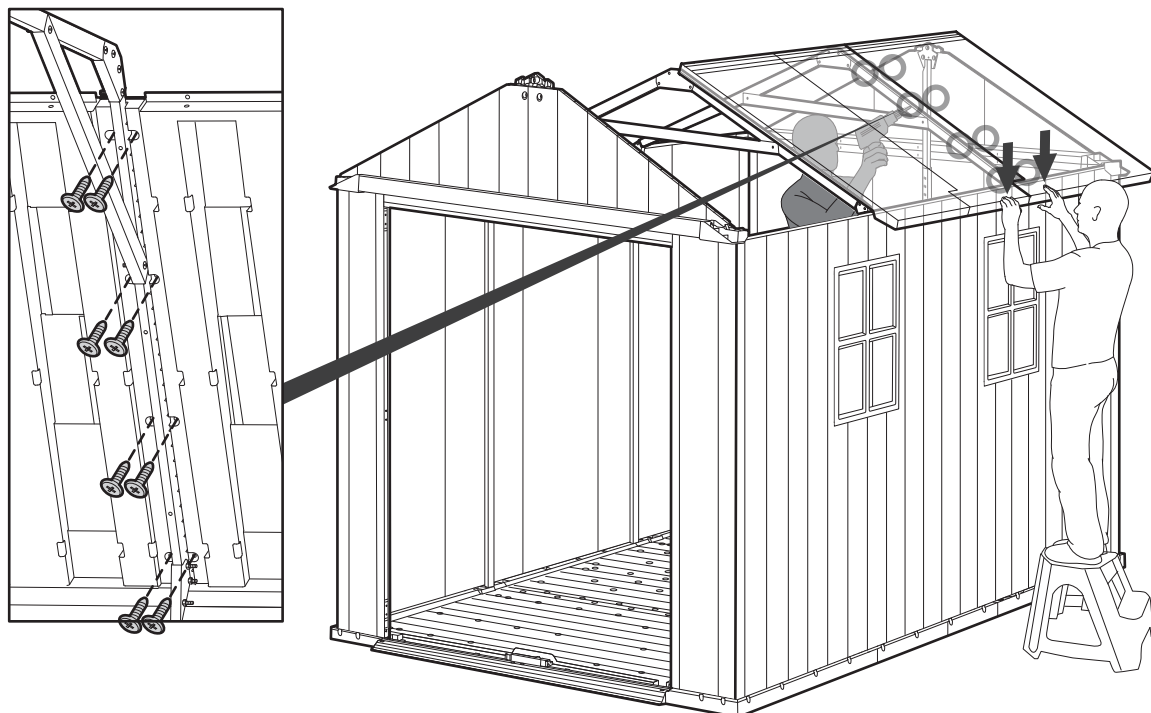
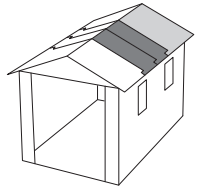

51

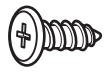

sc15 (x3)

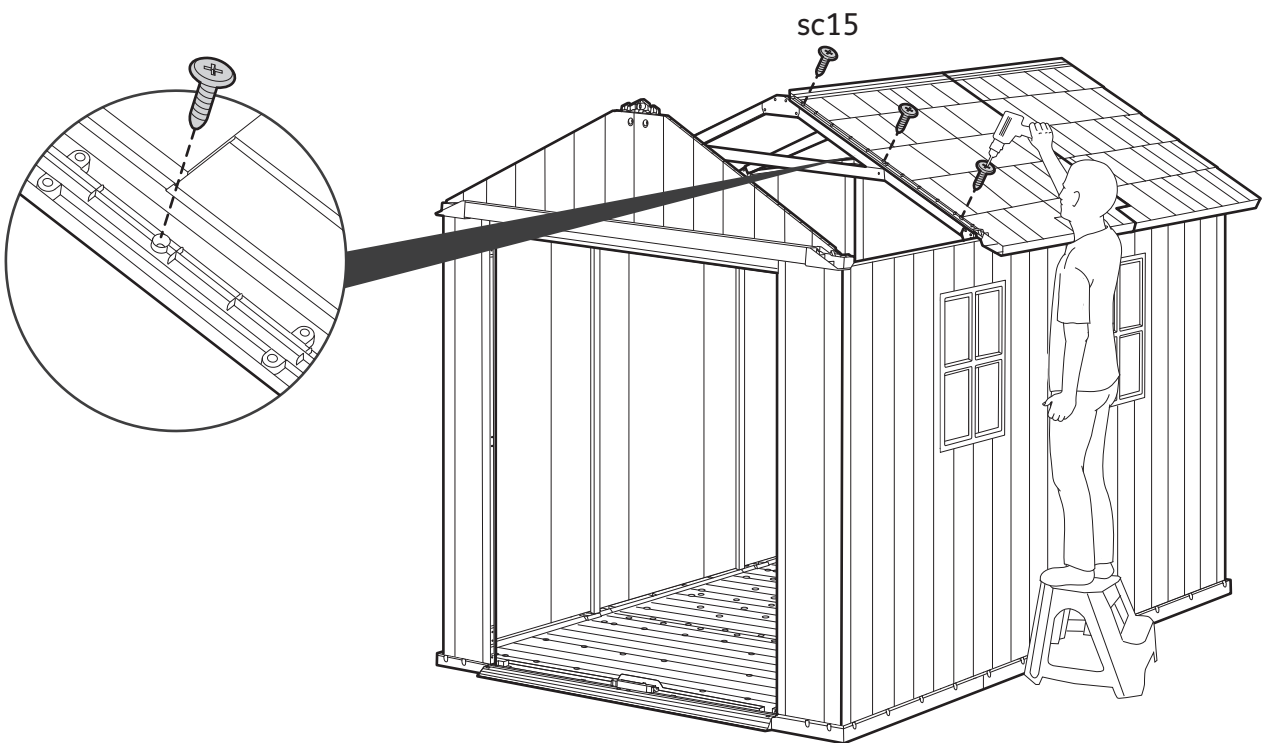
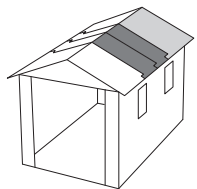

52

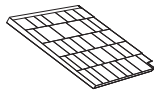

MOFTU (x1)

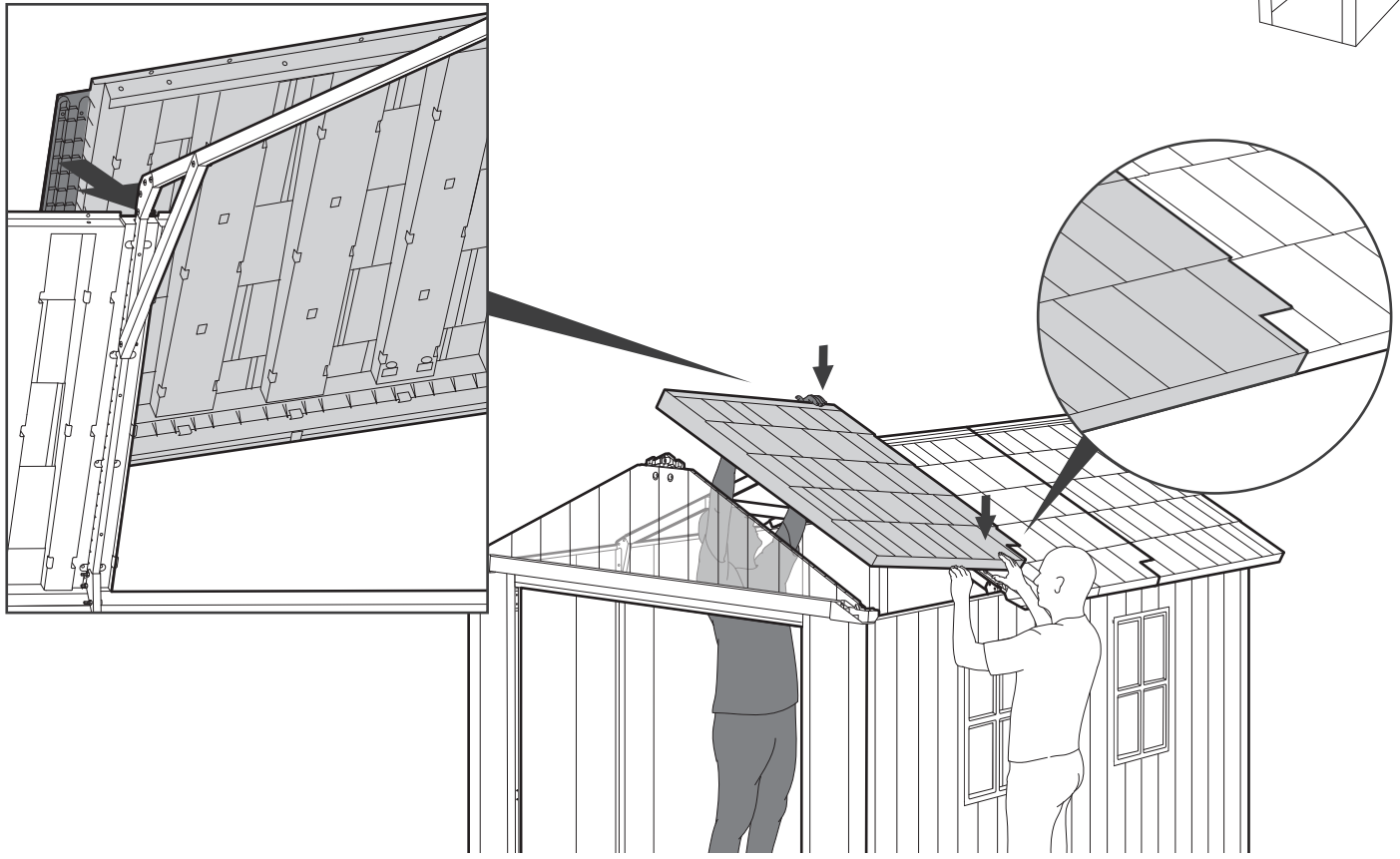
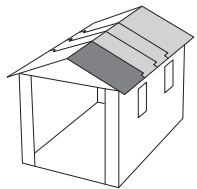

53

sc15 (x8)

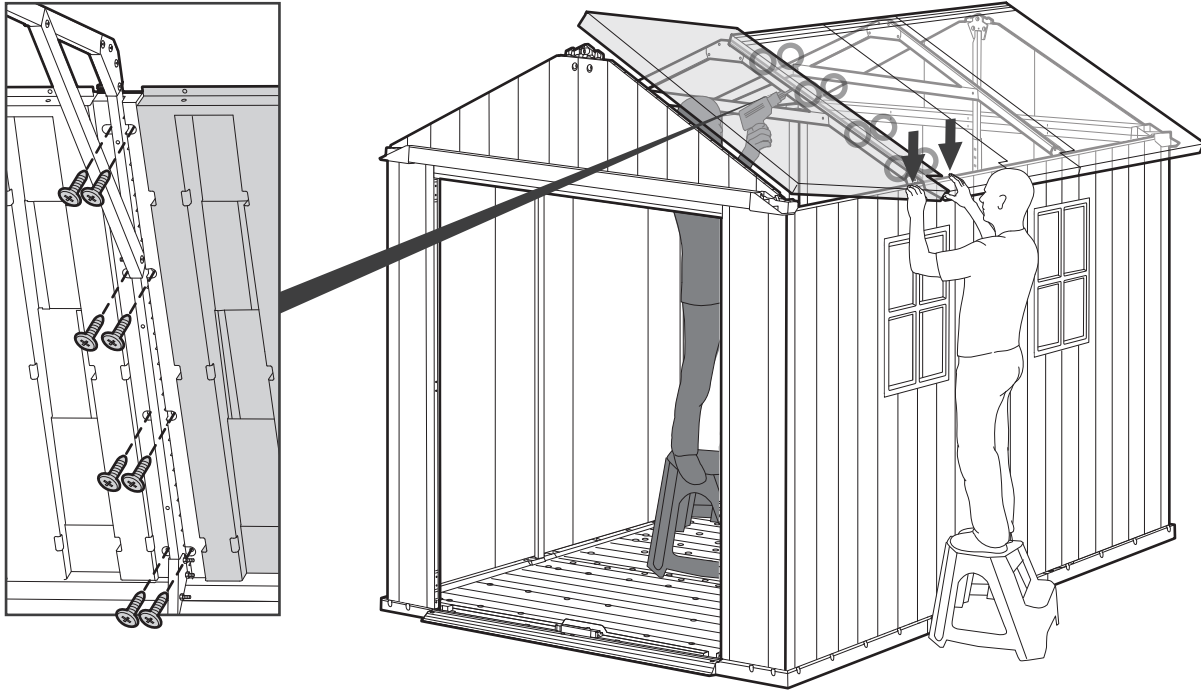
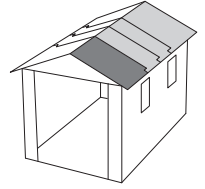

54

sc15 (x1)

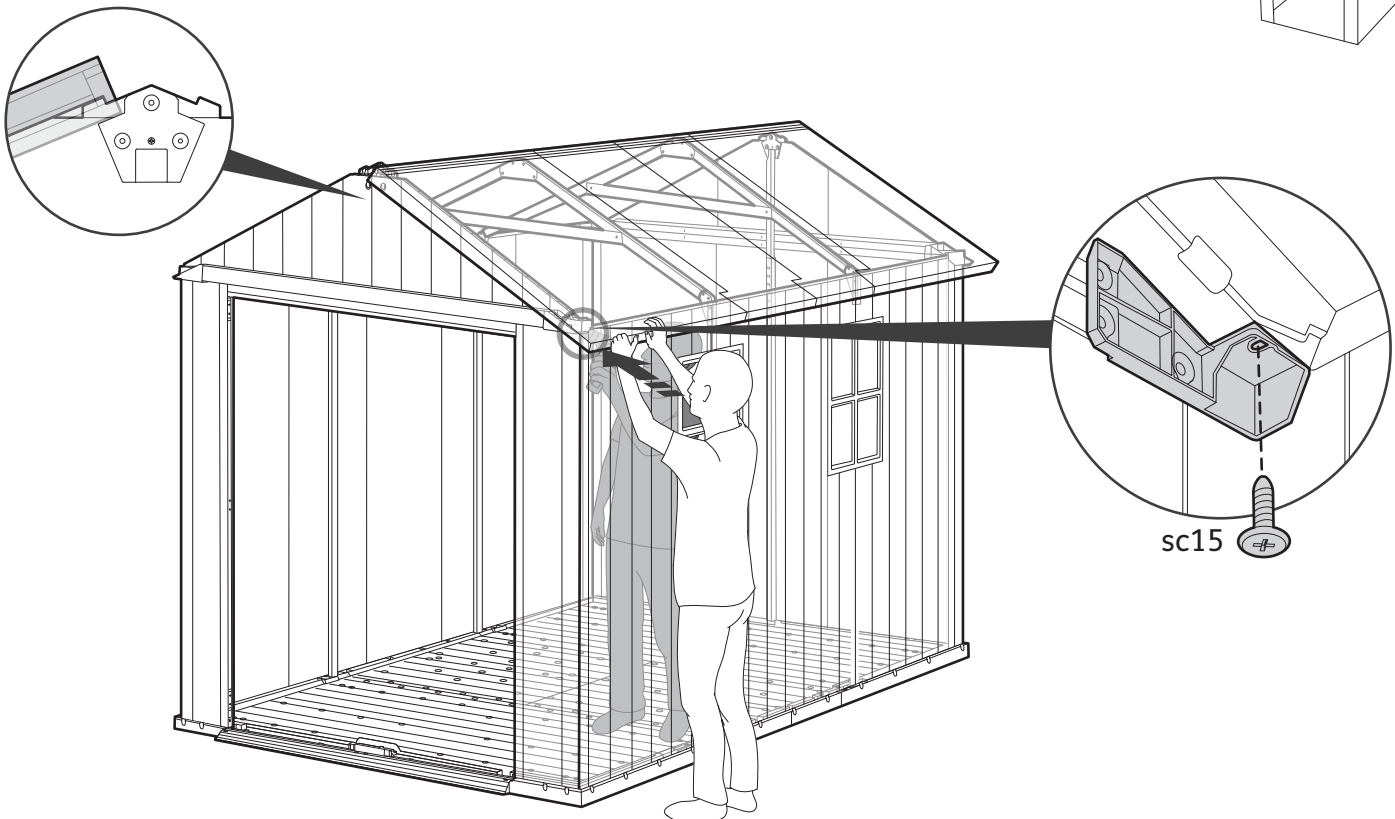
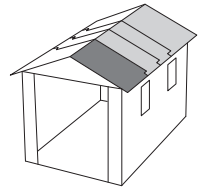

55

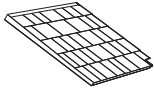

MOFTD (x1)

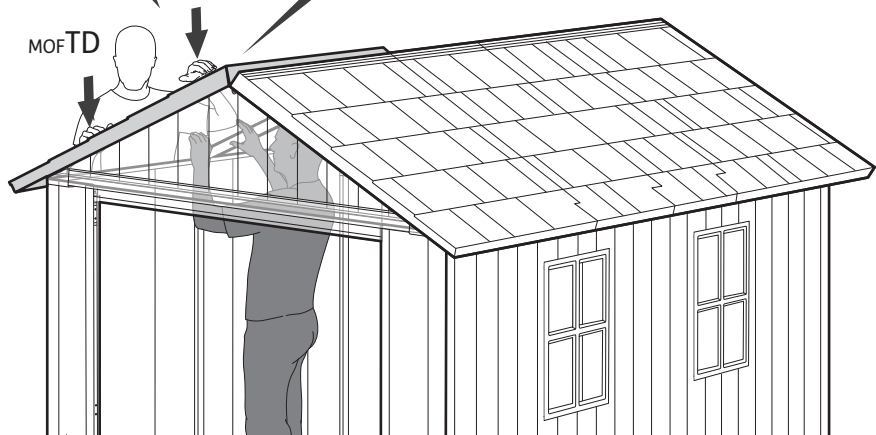
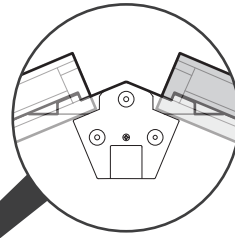
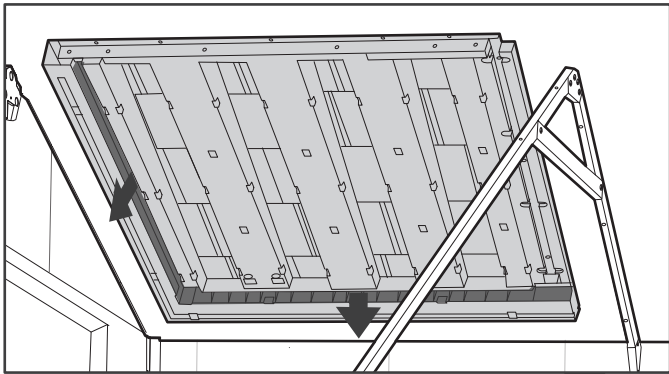
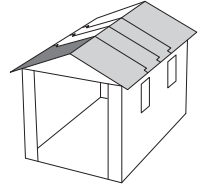

56

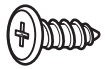

sc15 (x1)

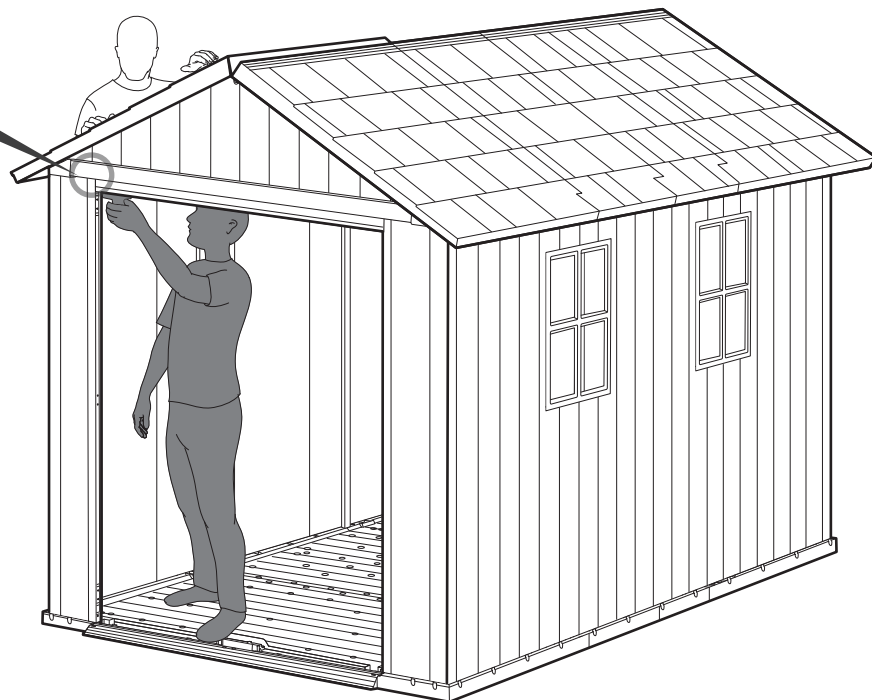
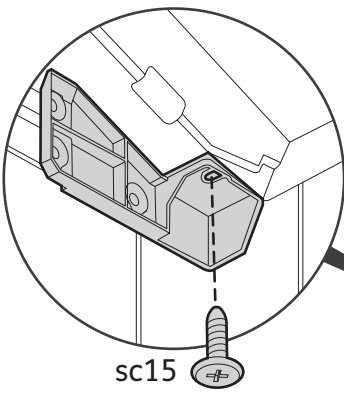
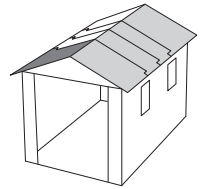

57

 sc15 (x3)

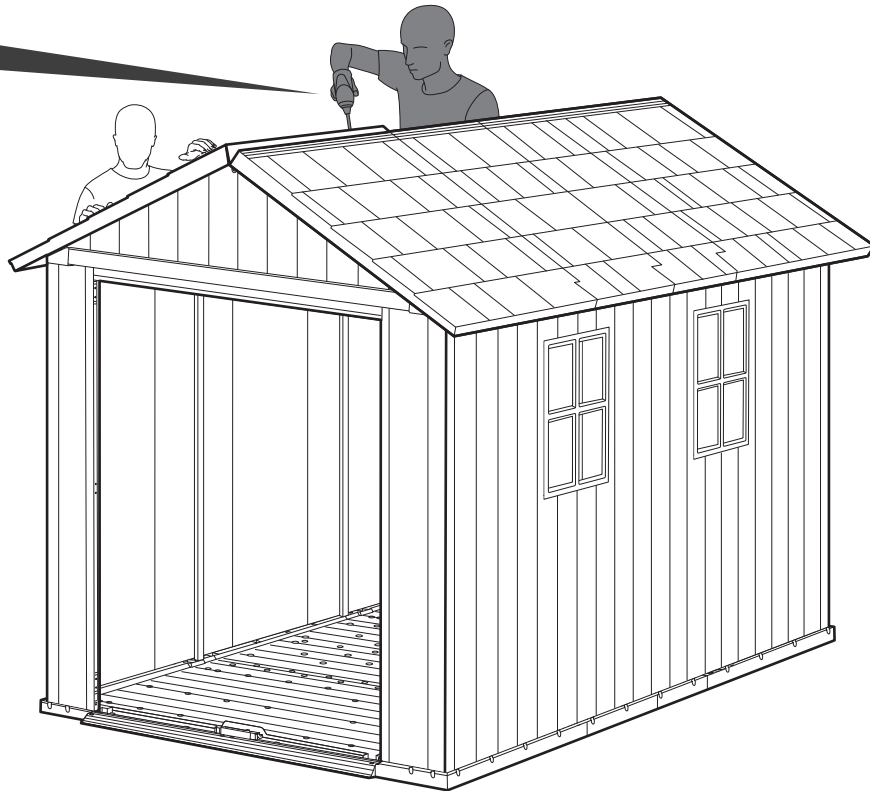
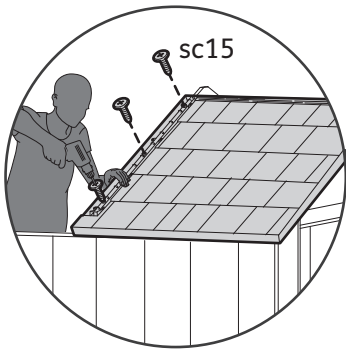
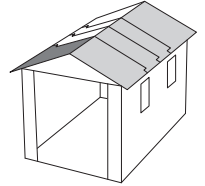

58

 MOFT9 + MOFT9 (x1)

 sc15 (x8)

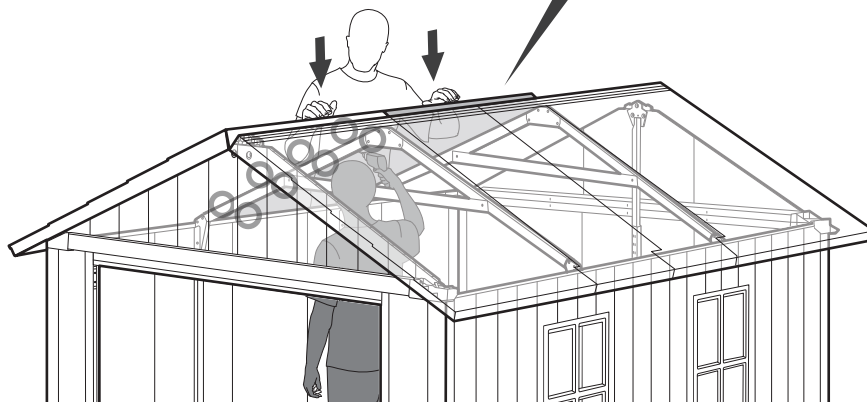
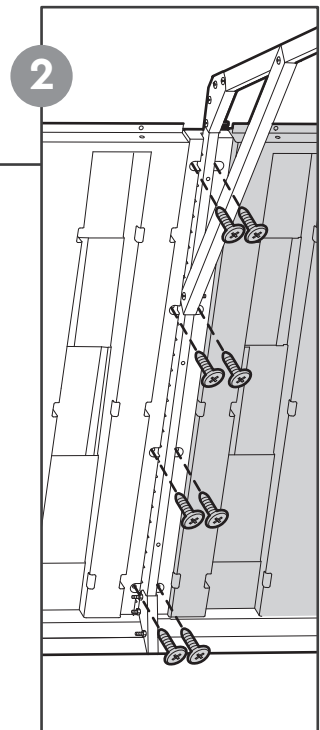
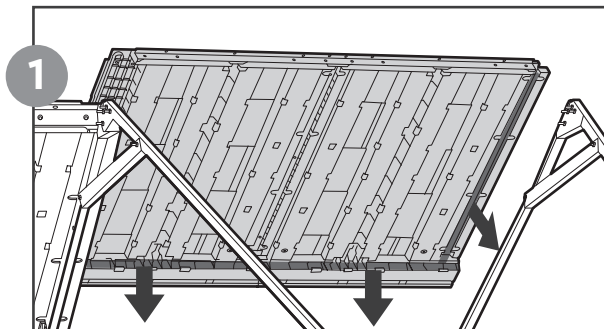
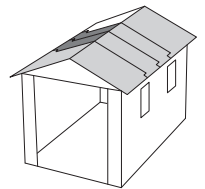

59

sc15 (x3)

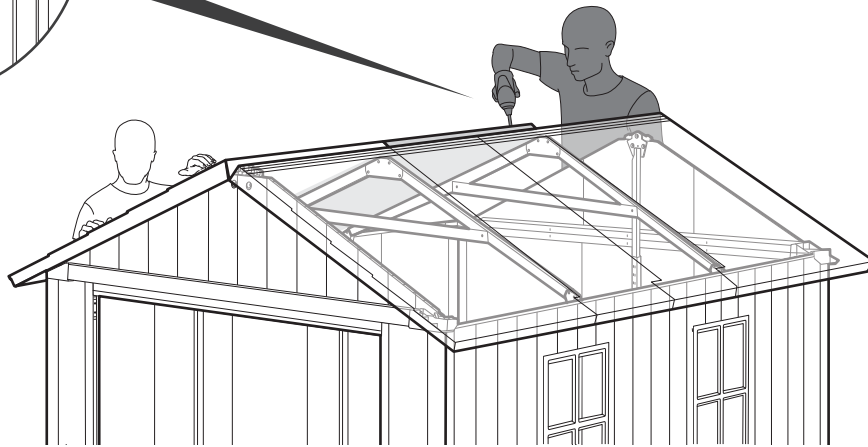
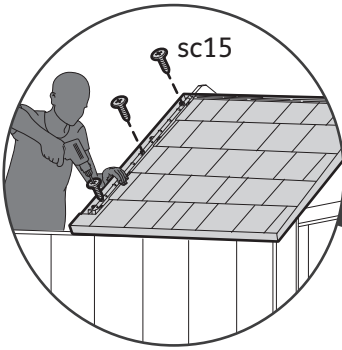
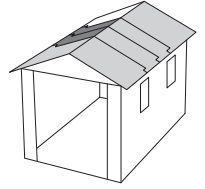

60

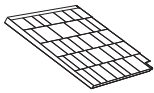

MOFTU (x1)



sc15 (x8)

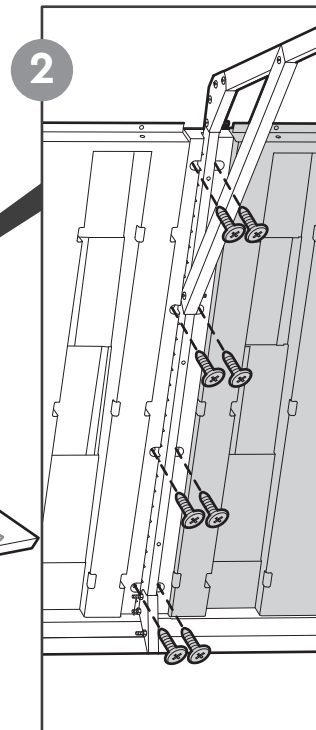
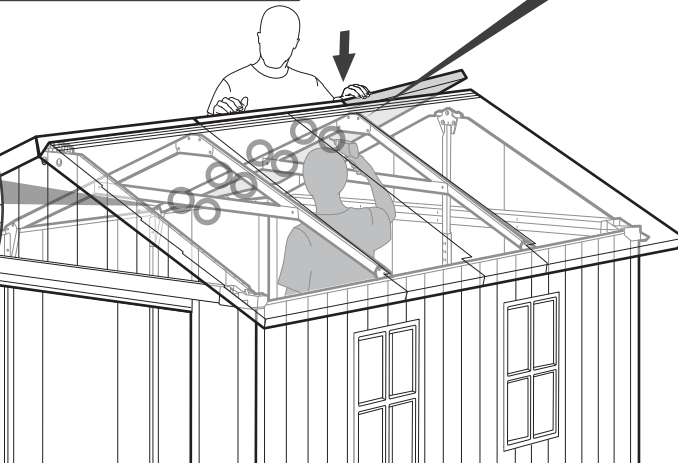
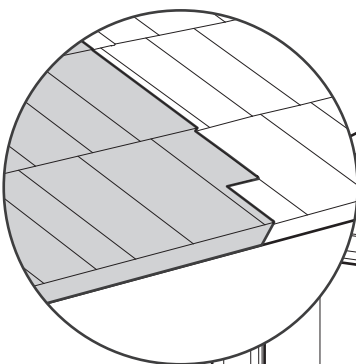
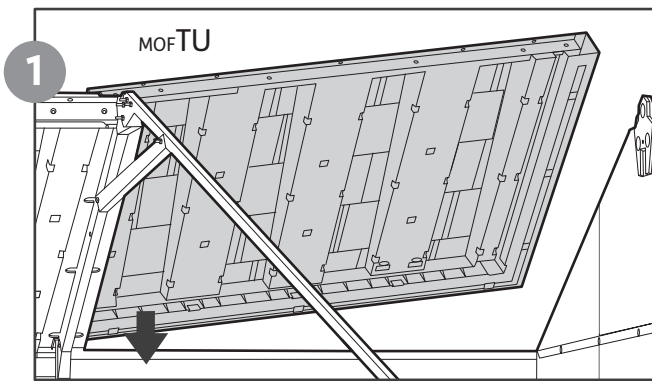
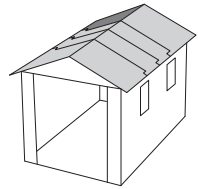

61

 sc15 (x1)

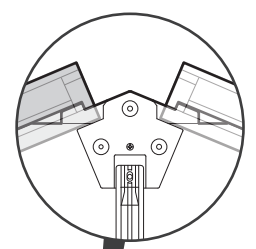
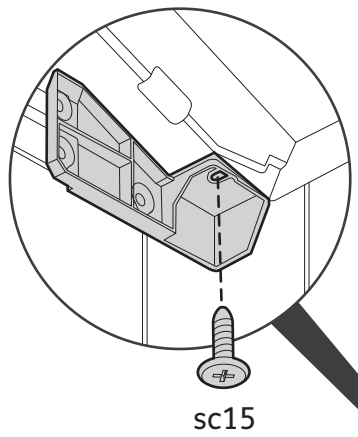
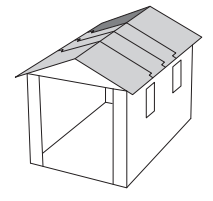

sc15

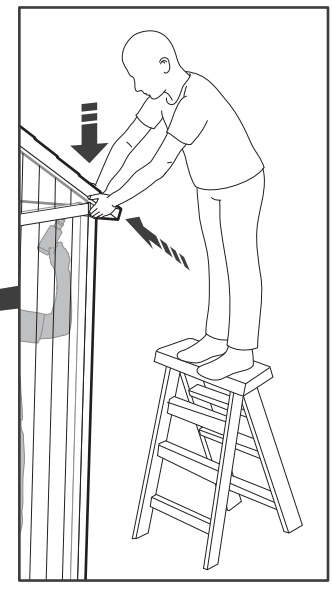
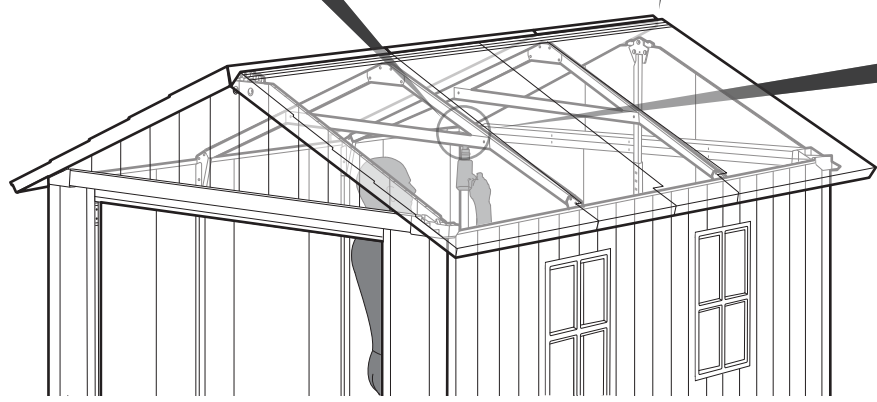

62

 moBC9 (x1)

 sc15 (x4)

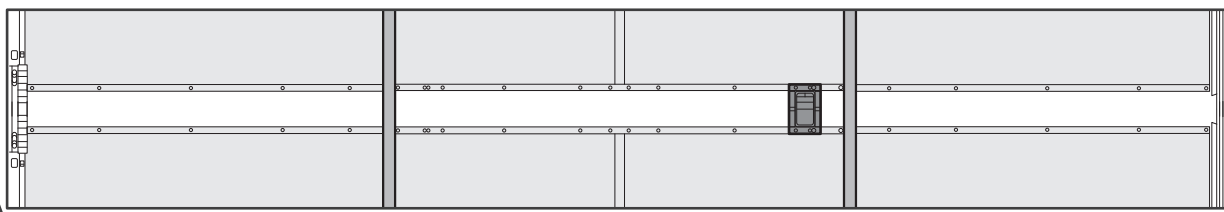
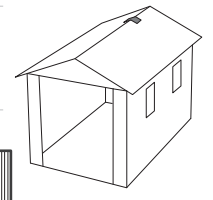

Front  
Avant  
Delante  
Vorderseite  
Voorkant  
Anteriore  
Frente

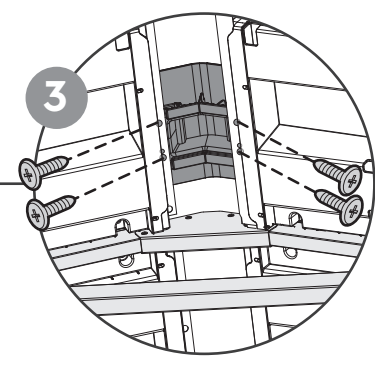
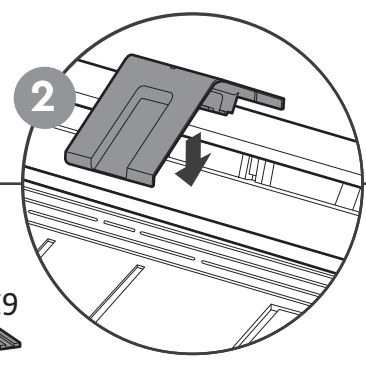
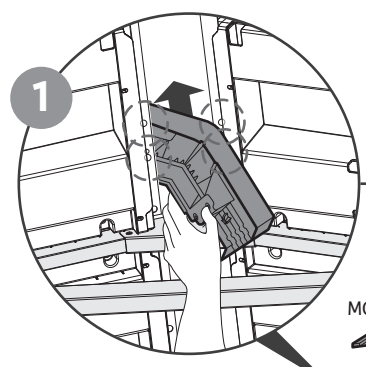

moBC9  

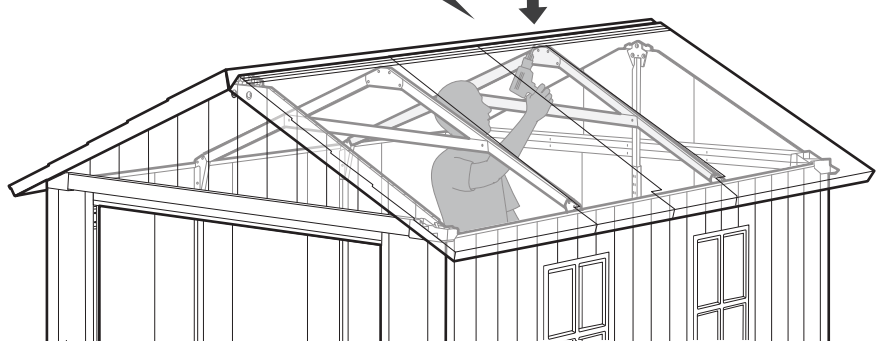
63

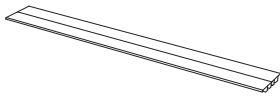

moB7 (x1)

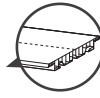
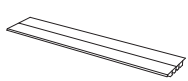

okEXT (x1)



moPLS (x2)

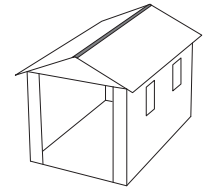

x2

1

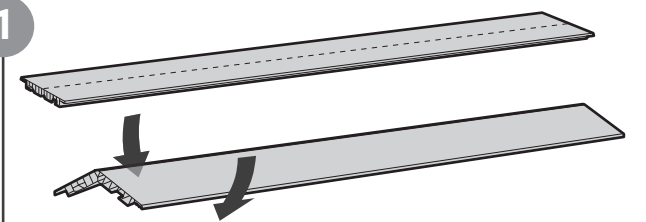

2

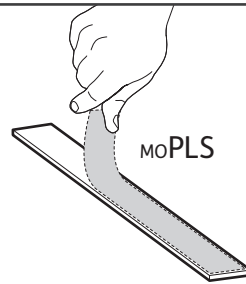

3

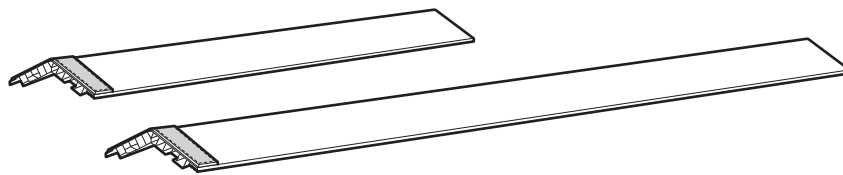
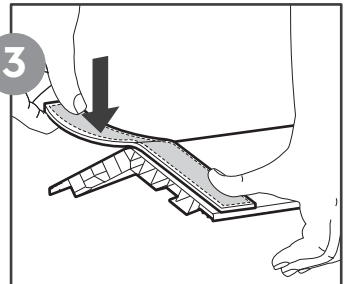

64



(x1)



(x1)

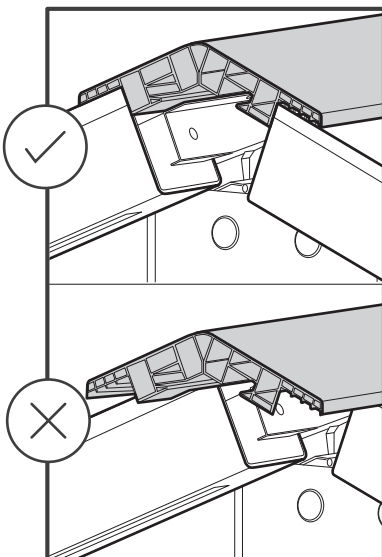
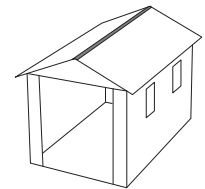

moB7

okEXT

1

2

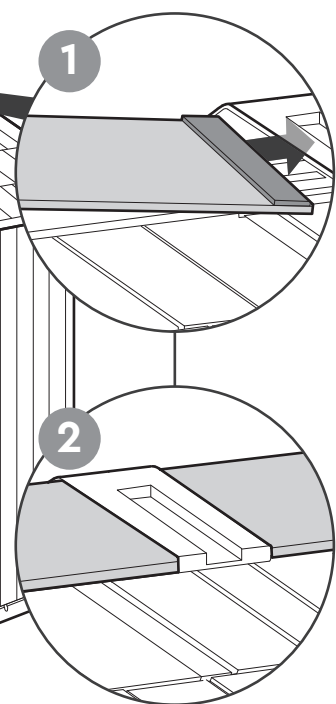
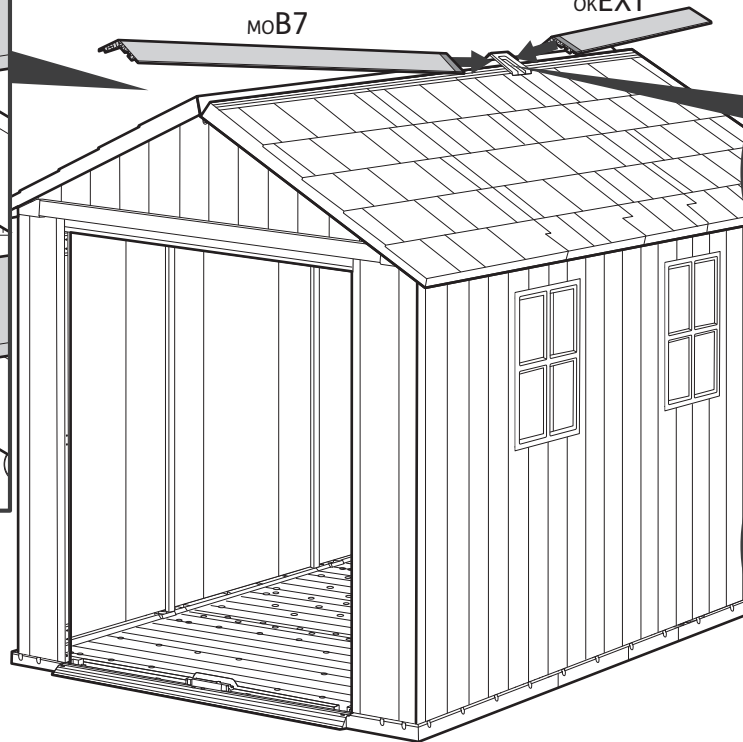

65

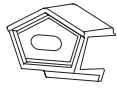

MOAC (x2)



sc15 (x6)

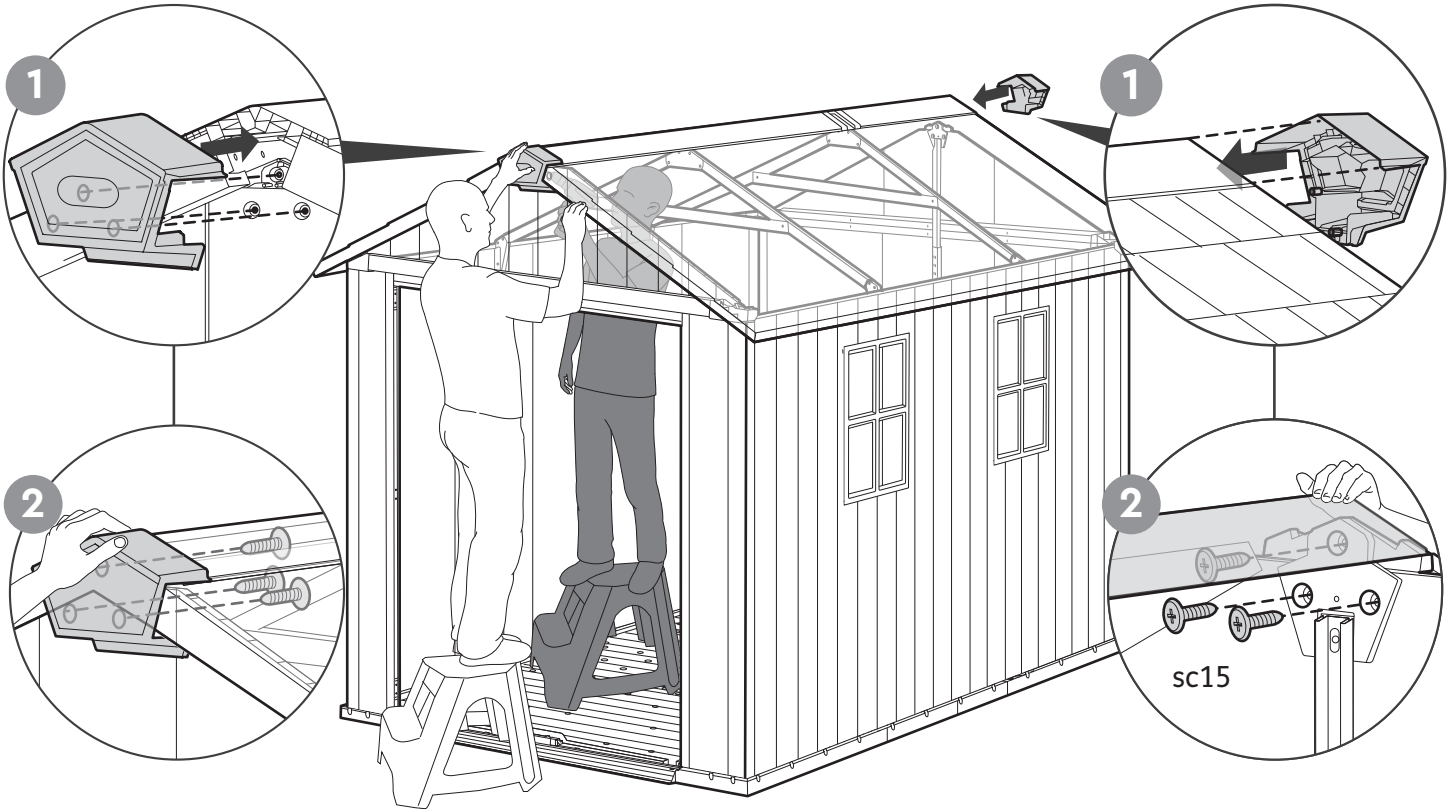
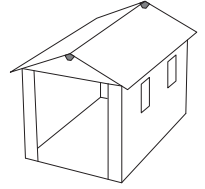

66



sc15 (x30)

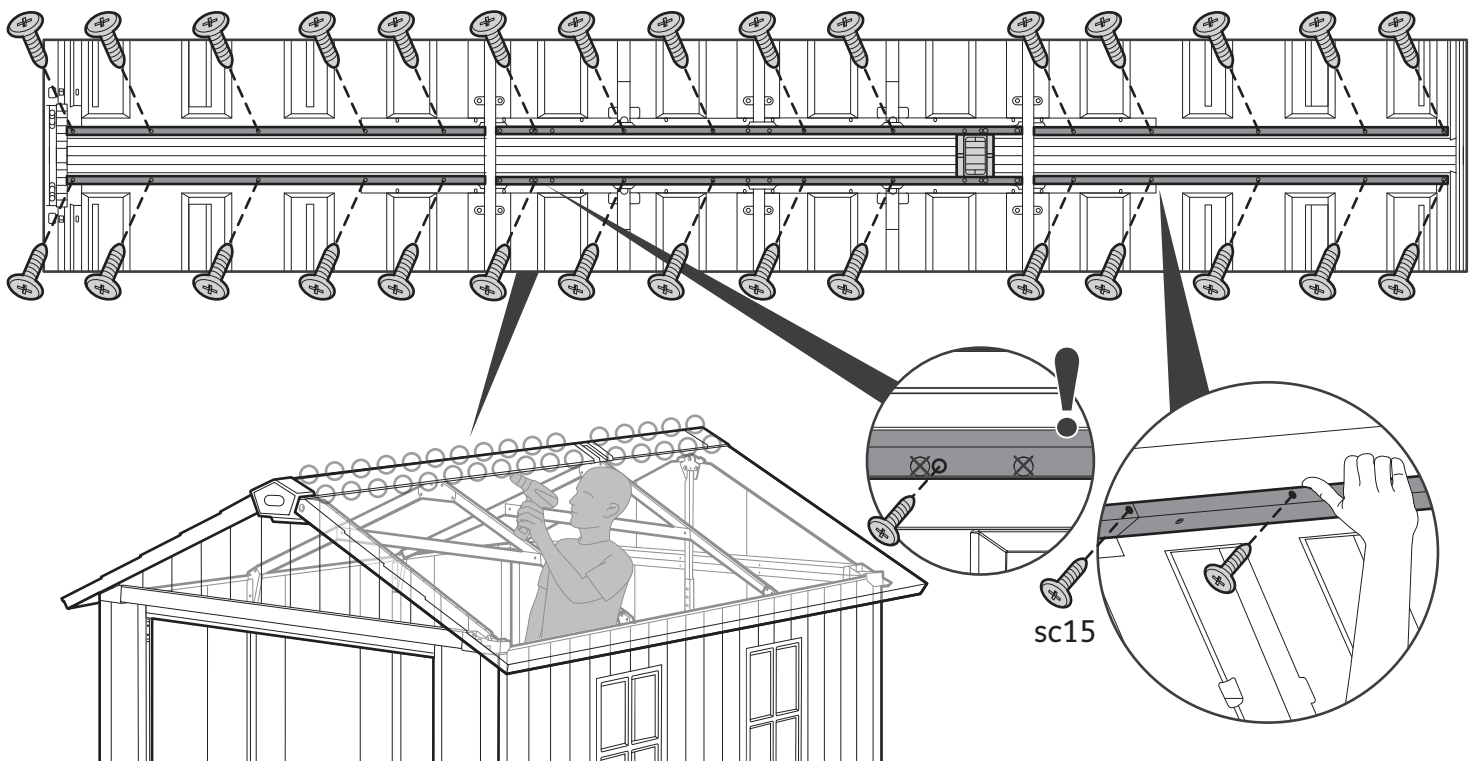
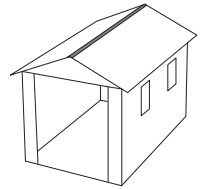

67

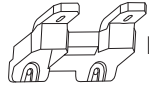

MOFTC (x4)



sc15 (x8)



s45b (x8)

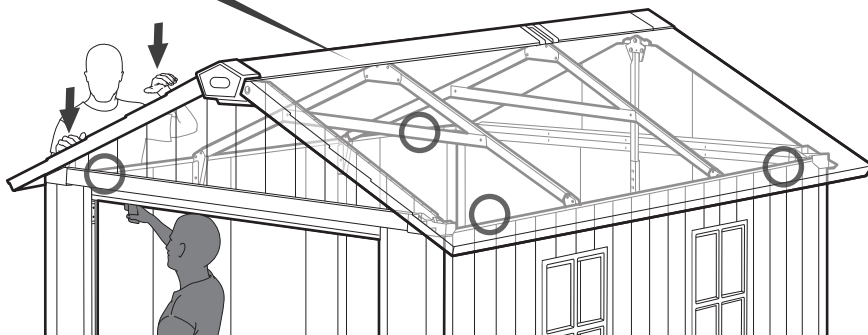
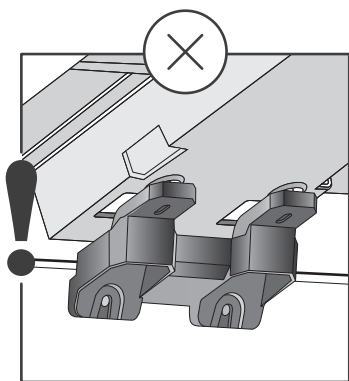
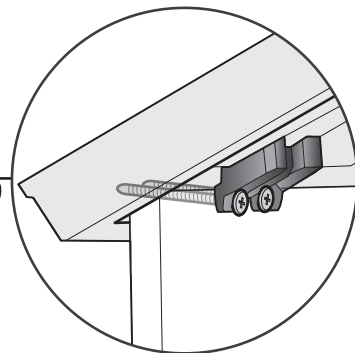
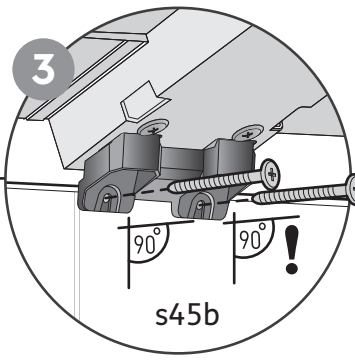
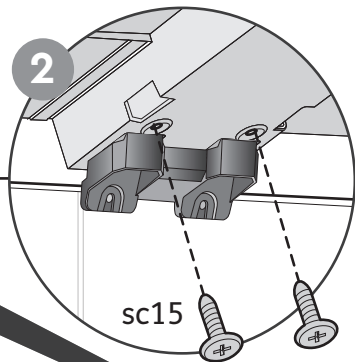
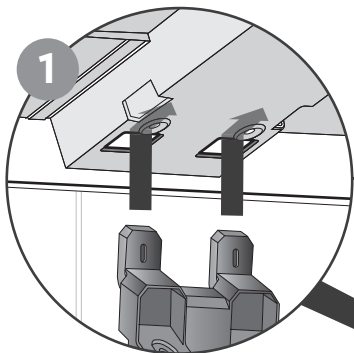
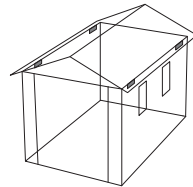

68



FNTM (x8)



sc15 (x8)



s45b (x8)

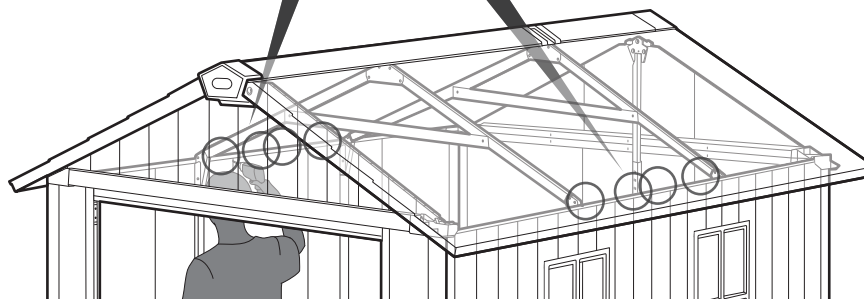
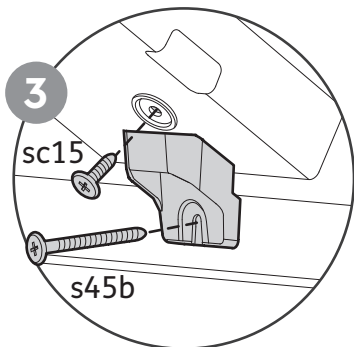
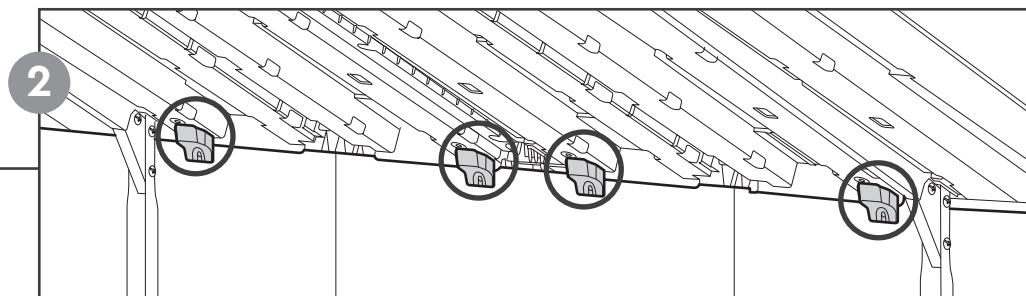
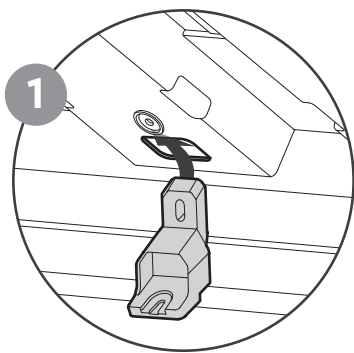
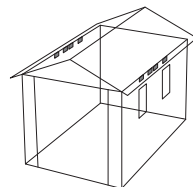

69

 s13b (x32)

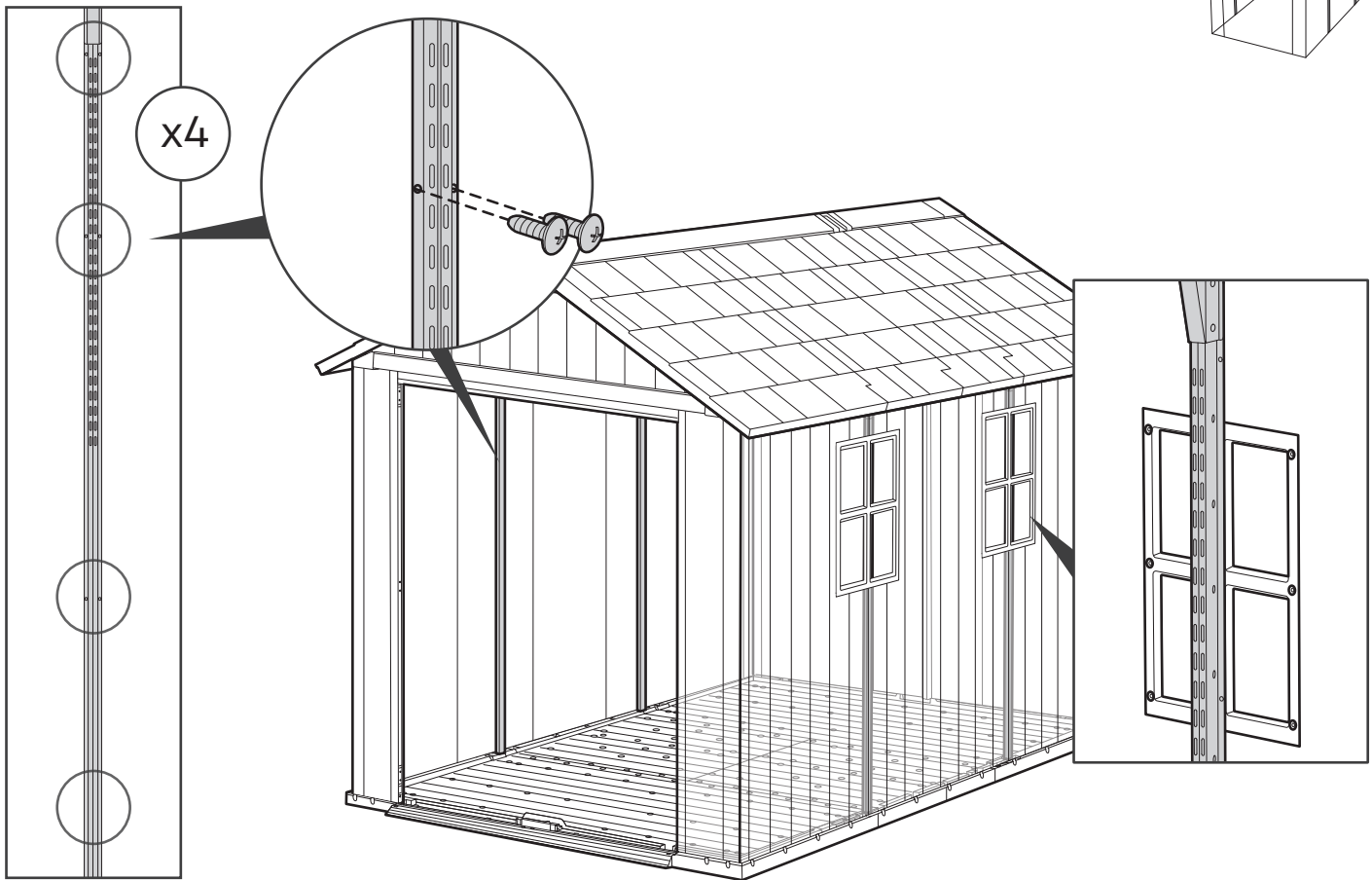
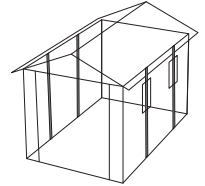

70

 s13b (x32)

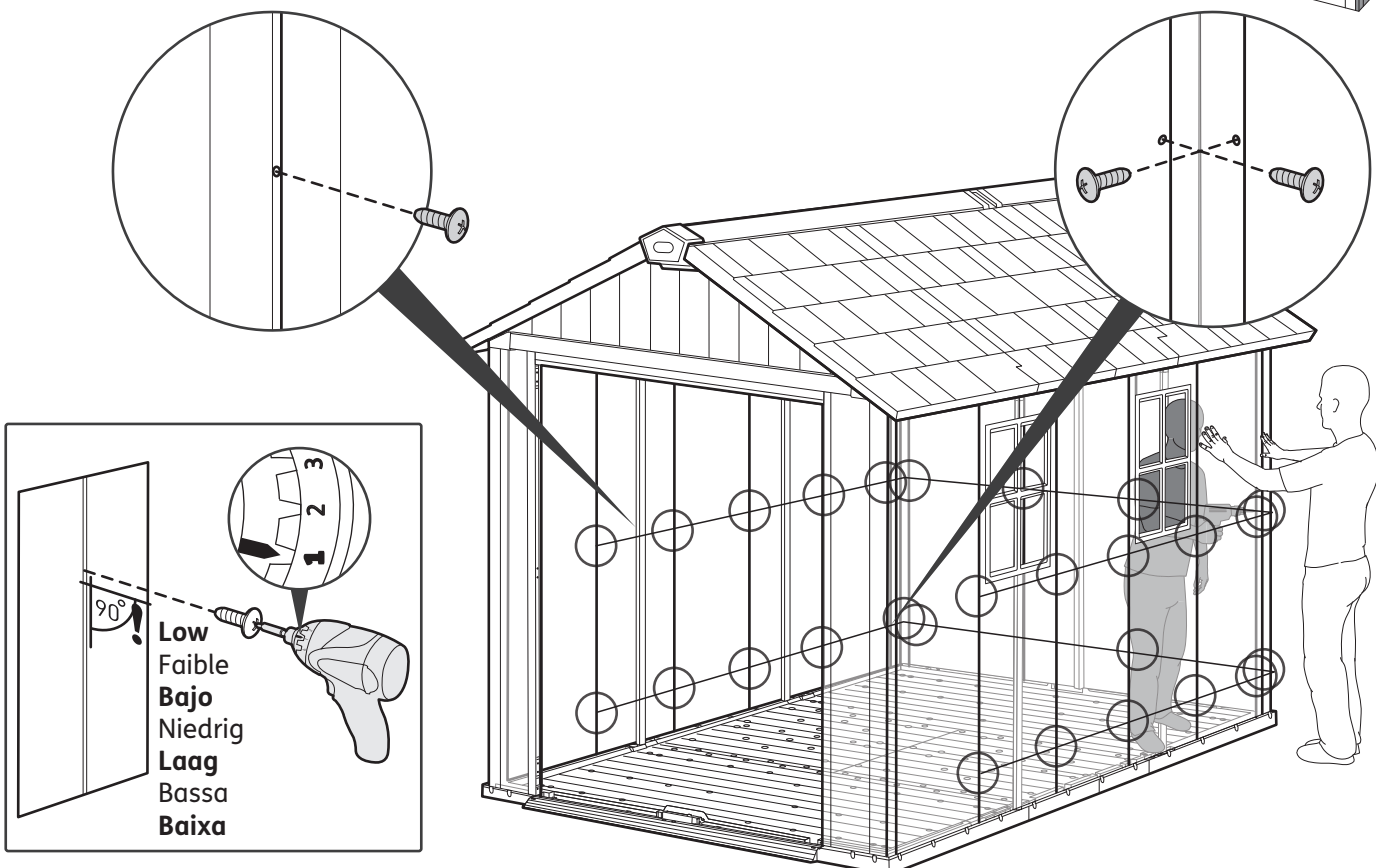
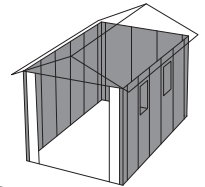

71

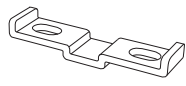

moRC (x6)



sc15 (x12)

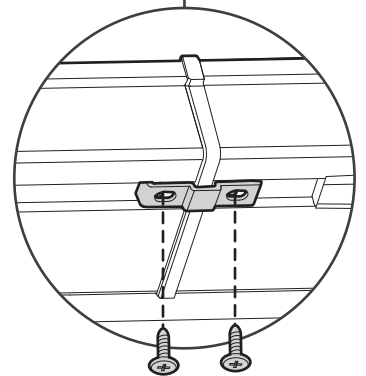
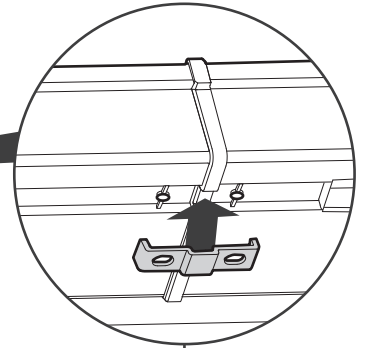
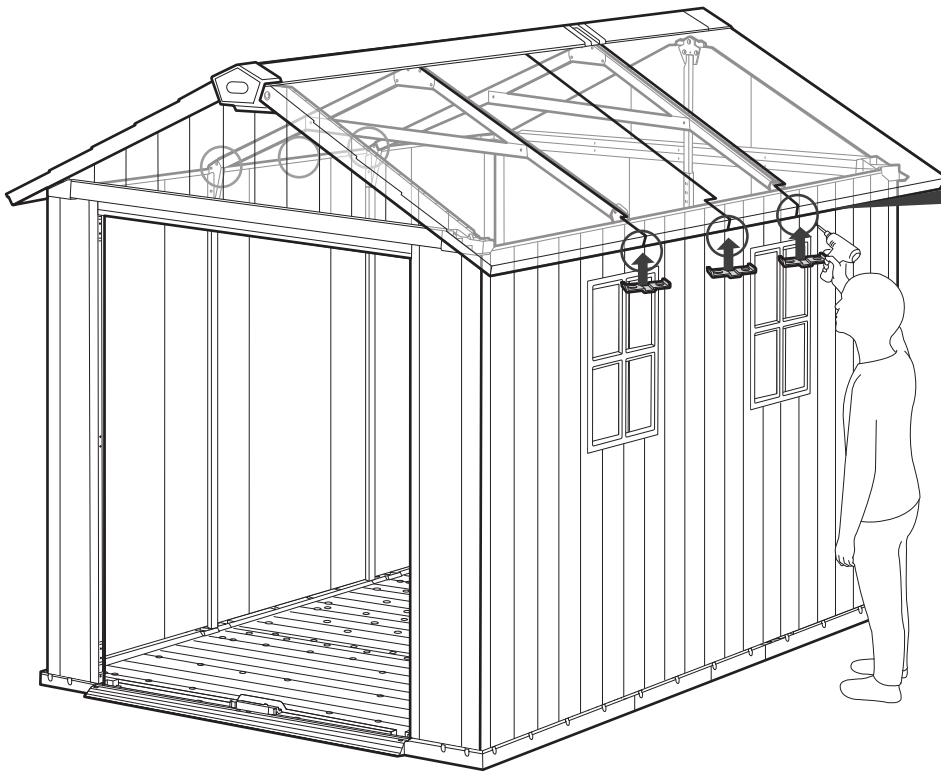
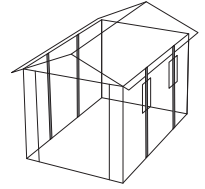

**DOOR ASSEMBLY | MONTAGE DE LA PORTE | MONTAJE DE LA PUERTA | MONTAGE DER TÜR | DEURMONTAGE | ASSEMBLAGGIO DELLA PORTA | MONTAGEM DA PORTA**

72

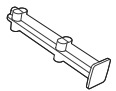

nuHF (x2)



neDOR (x1)

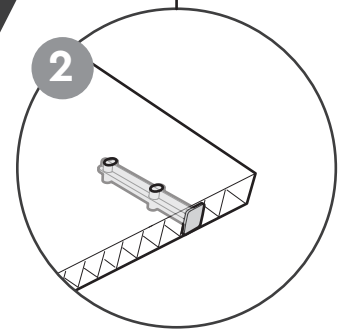
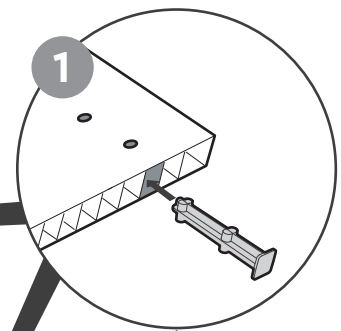
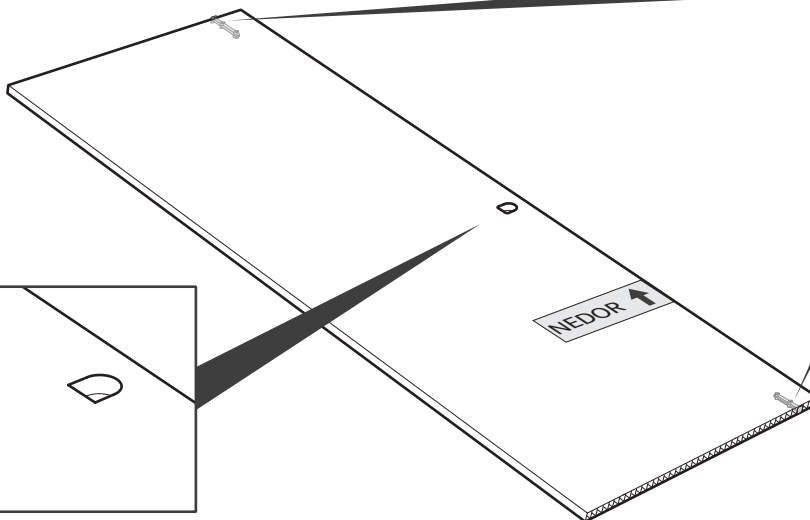
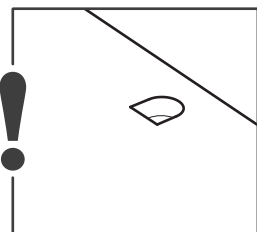
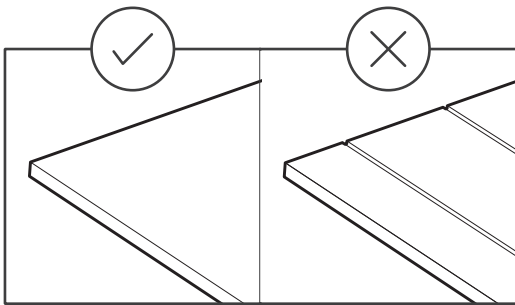
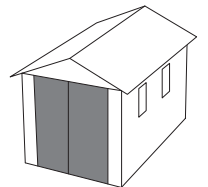

73



NEDOR (x1)



NEDOL (x1)



NEPD (x4)

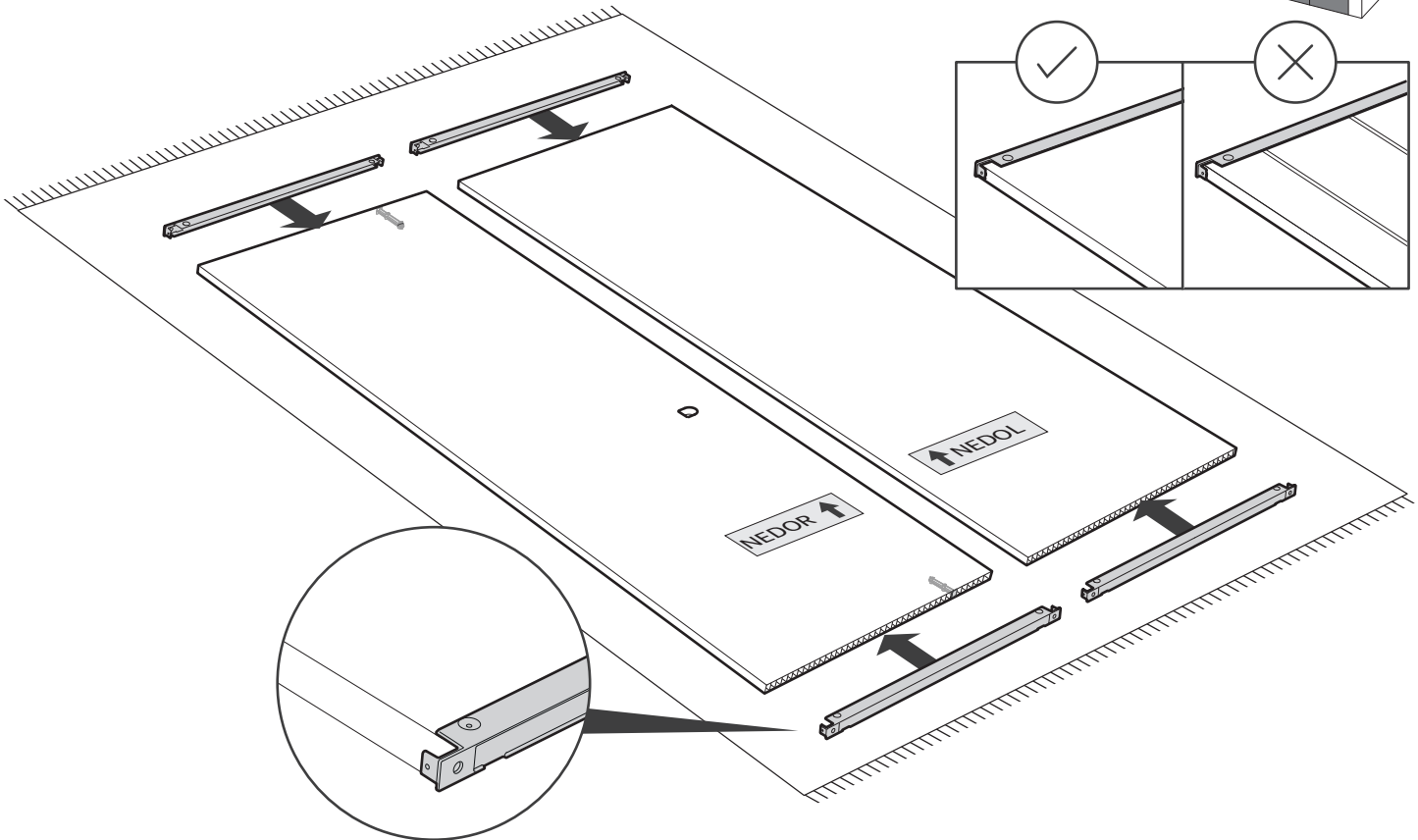
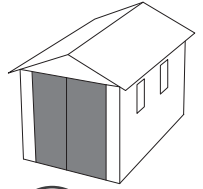

74

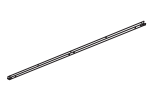

NWDSO (x2)



NWDSI (x1)



NWDSW (x1)

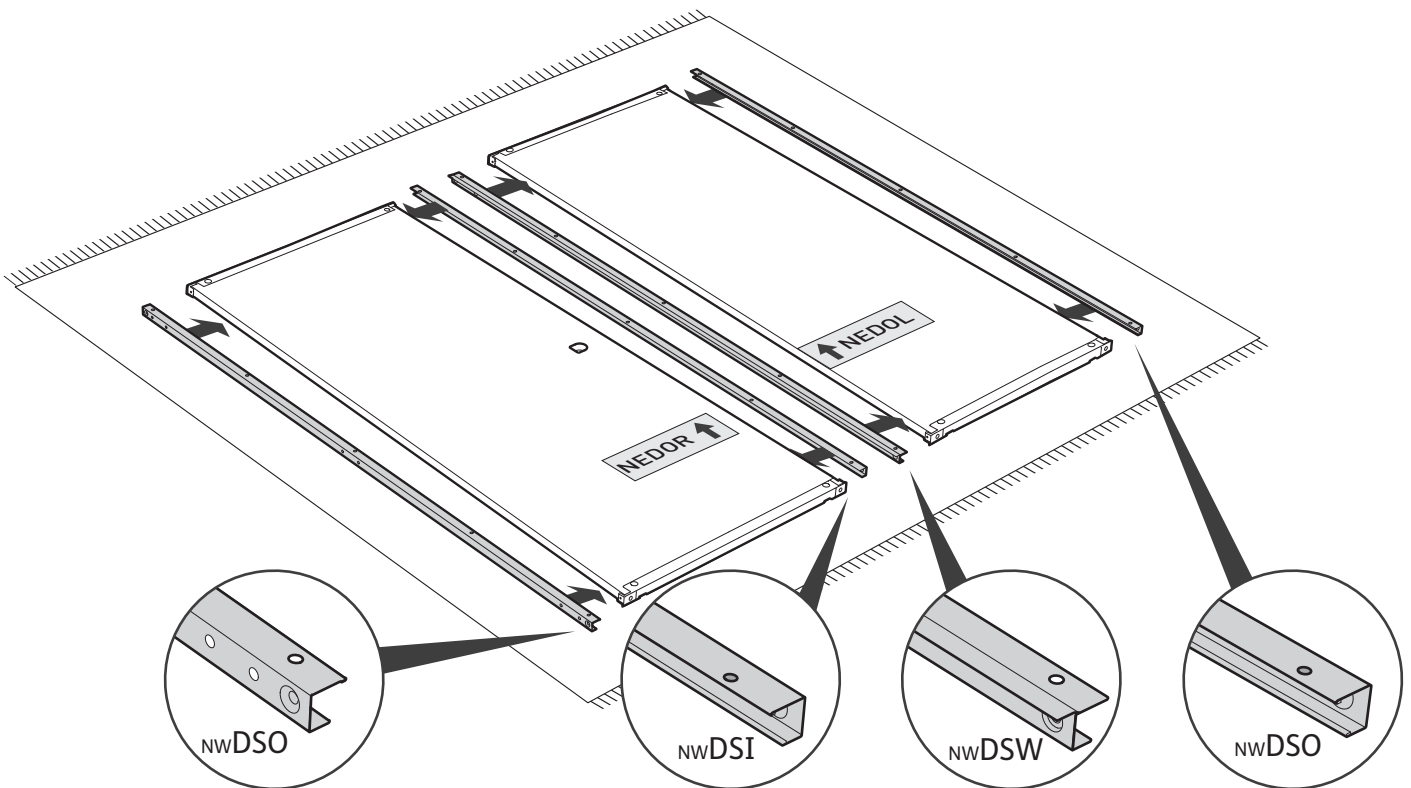
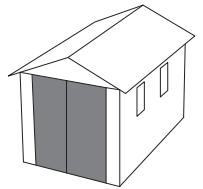

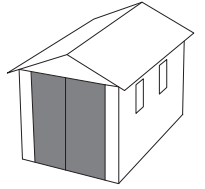

75

sc15 (x8)

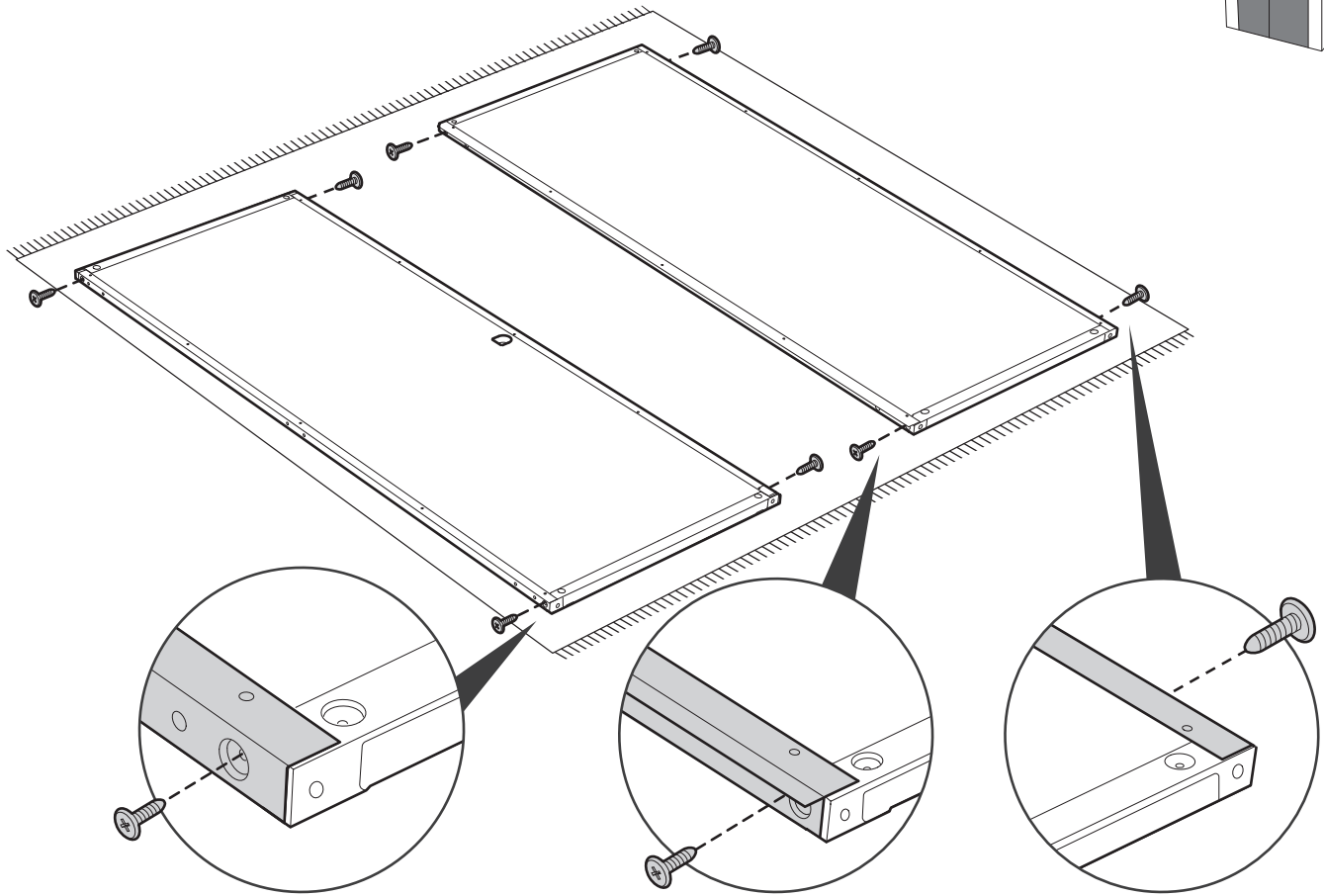

76

NUHG (x2)

NUHH (x2)

sc15 (x4)

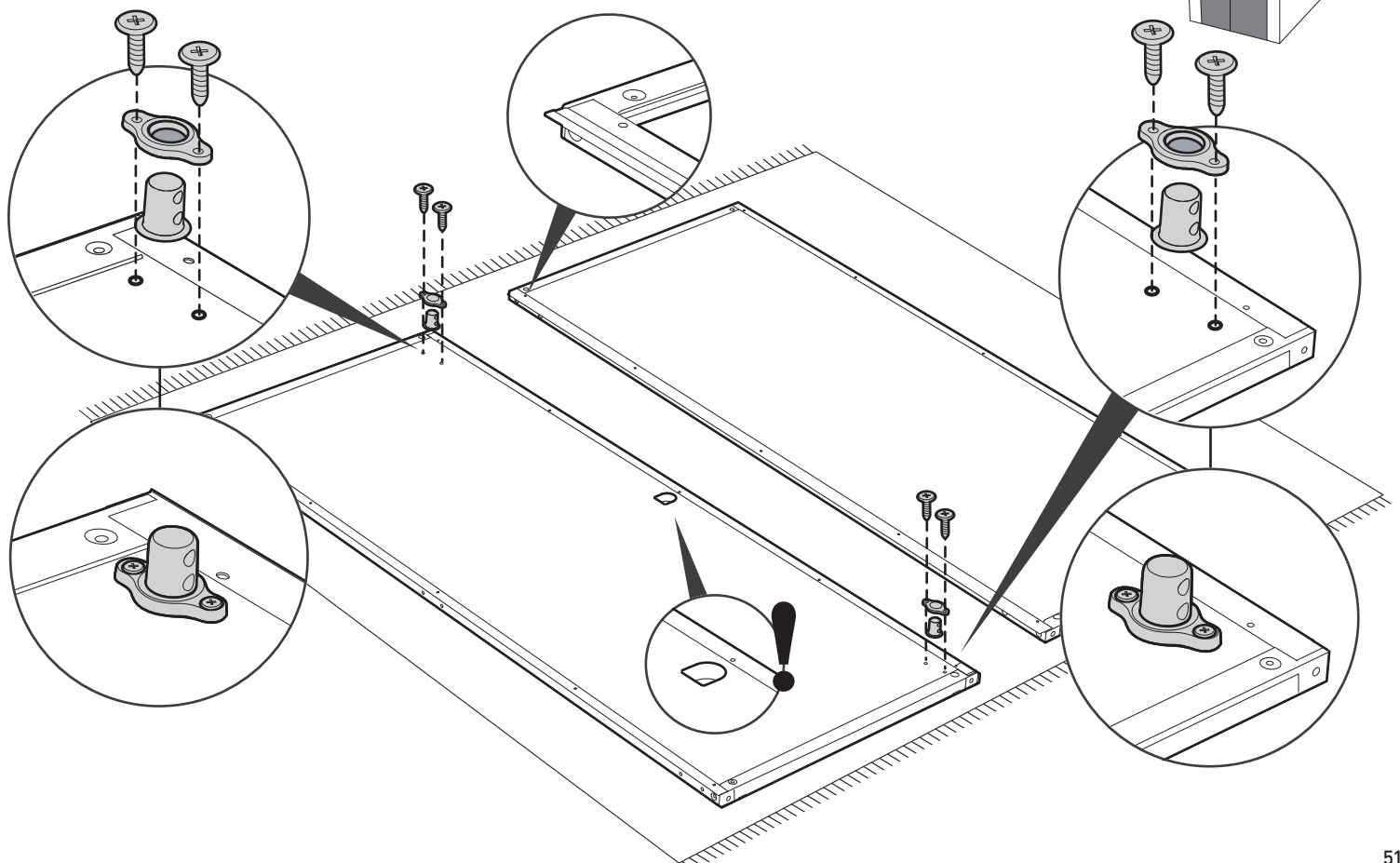
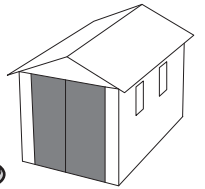

77

sc15 (x28)

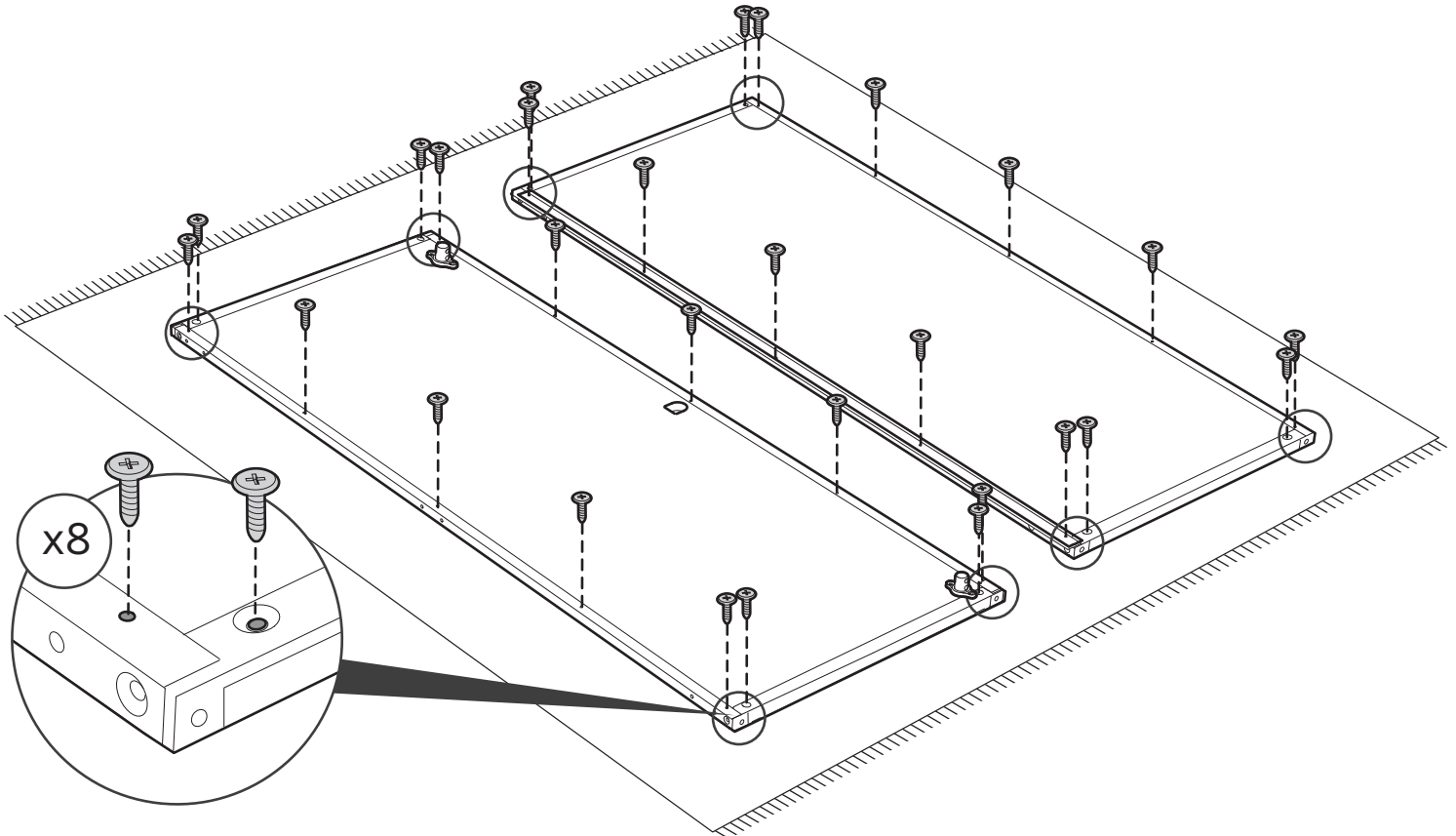
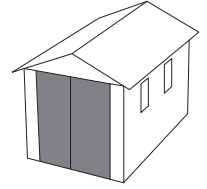

78

NEDH (x6)

sc15 (x12)

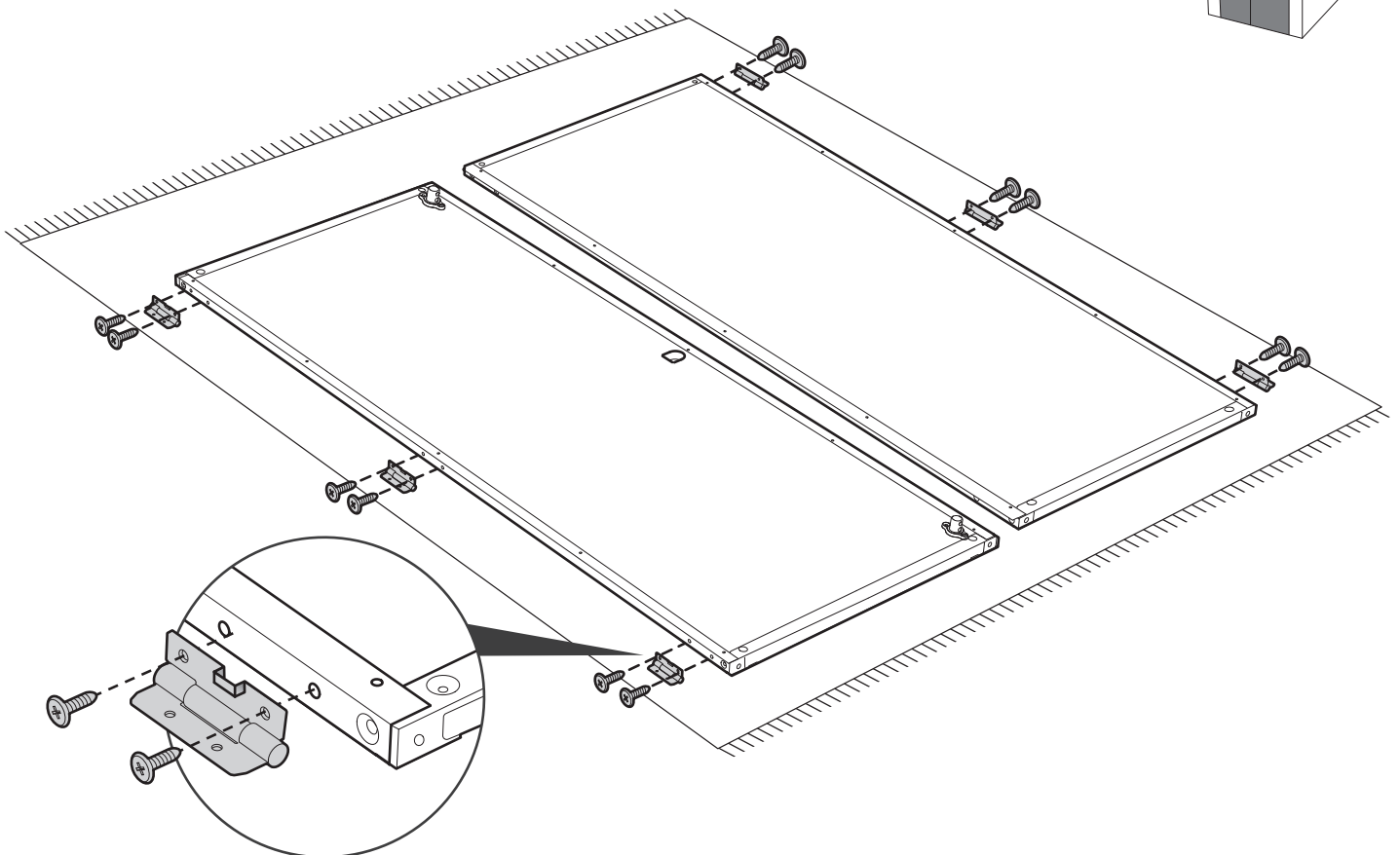
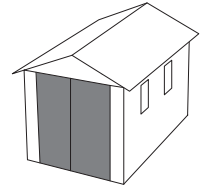

79

 sc7t (x12)

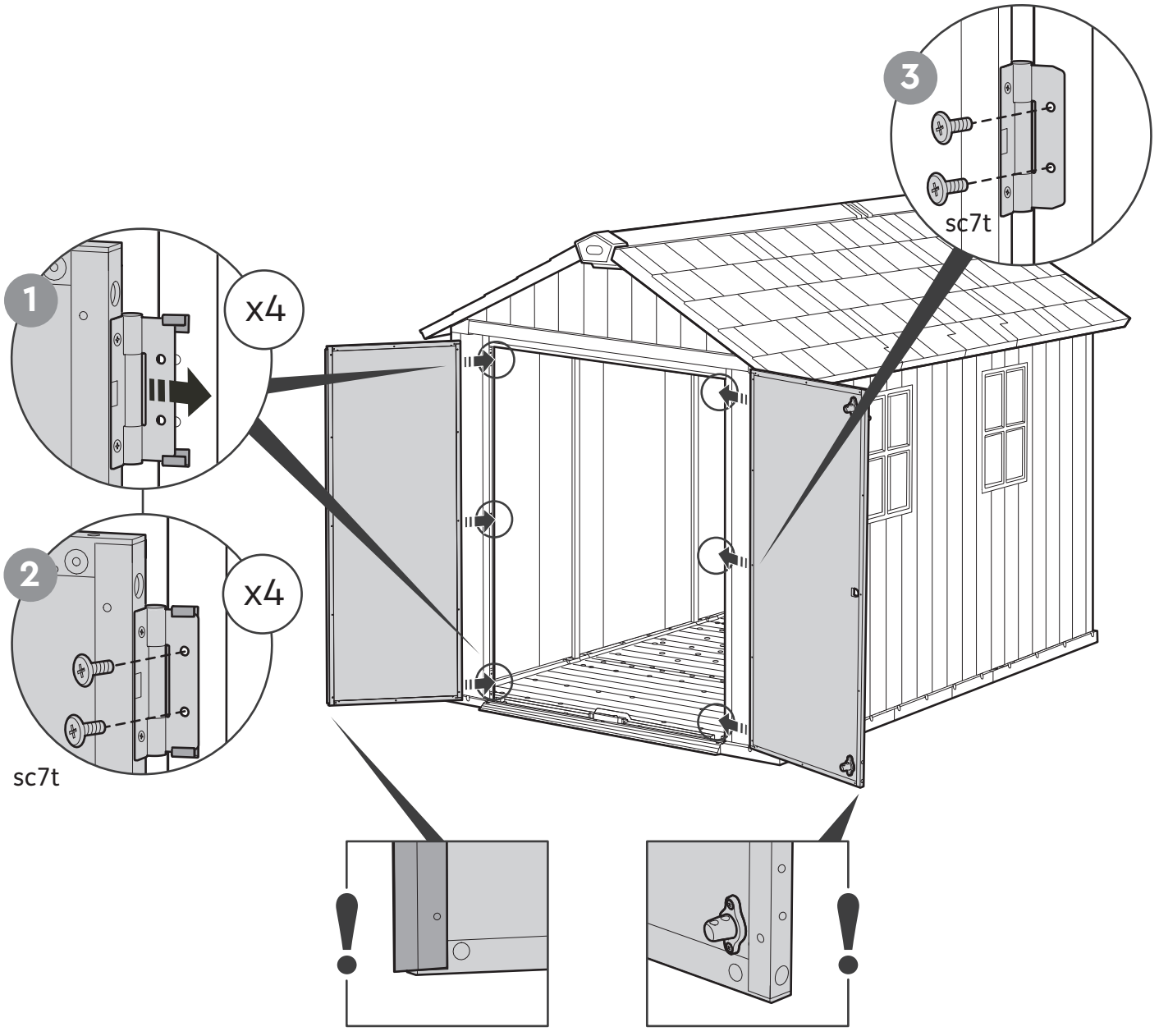
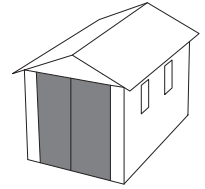

80

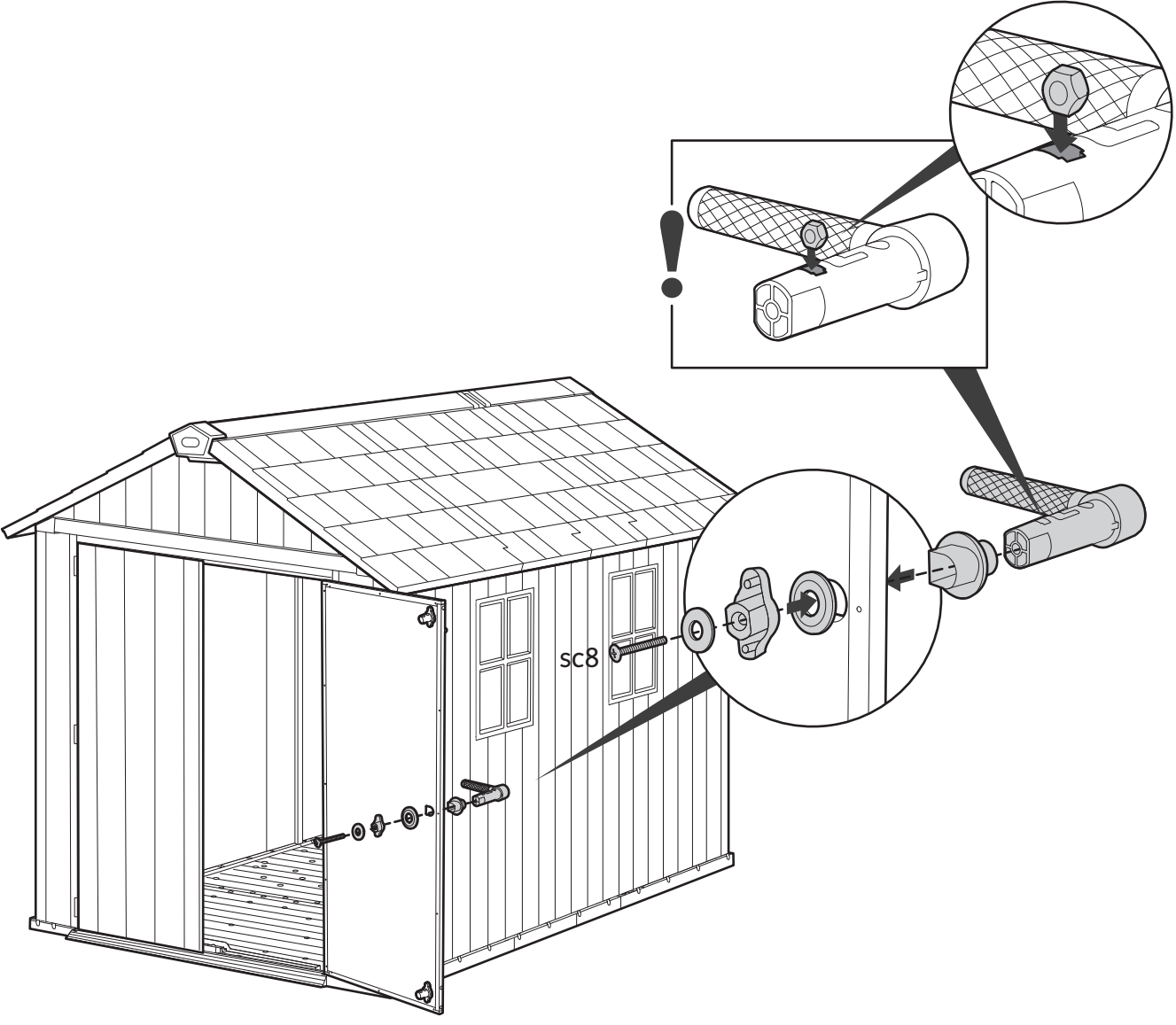
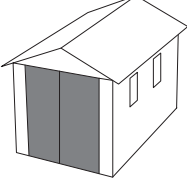
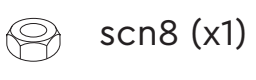

81



NUHE (x1)



NEMB (x2)

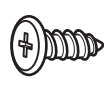

sc15 (x2)

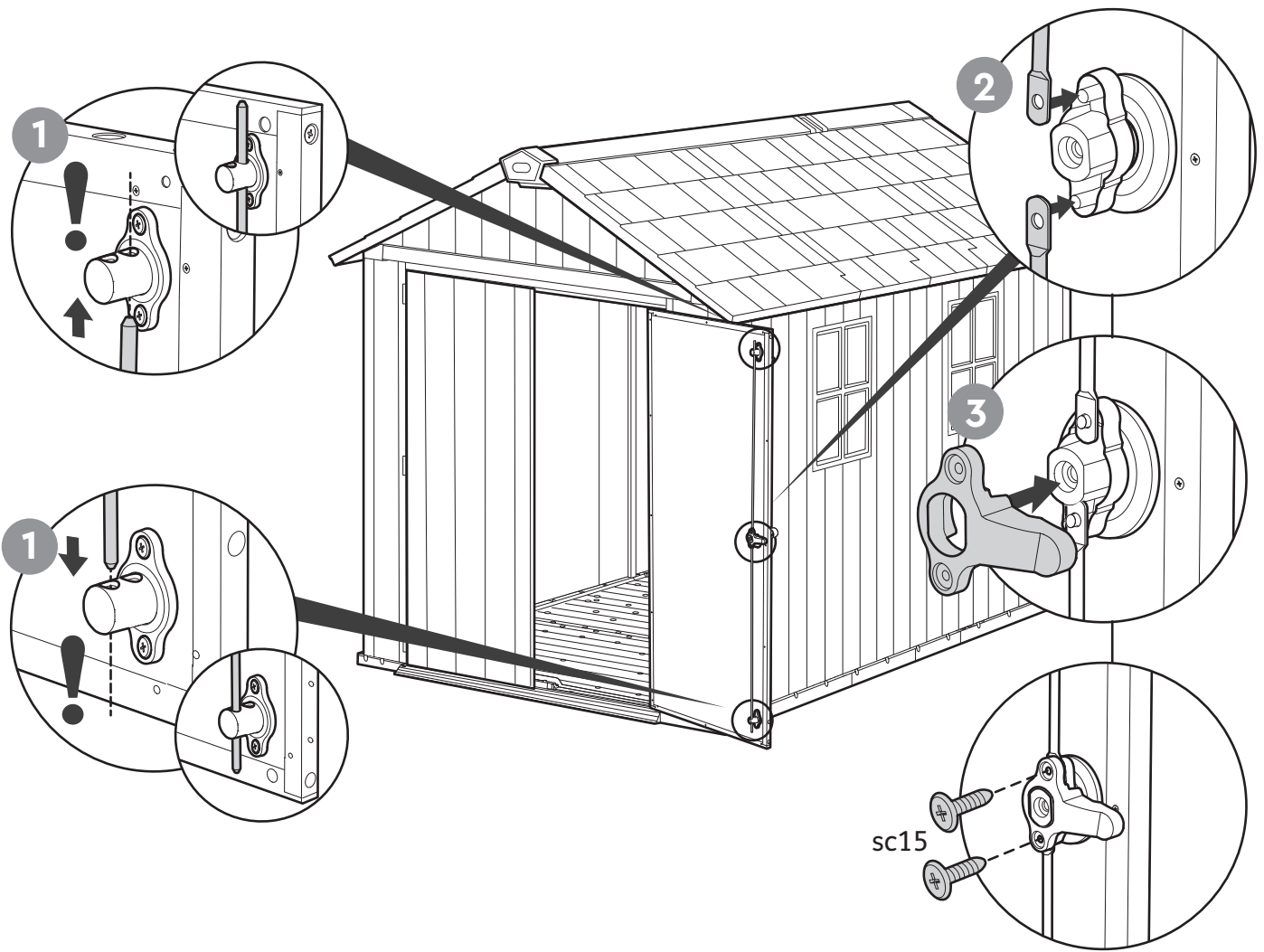
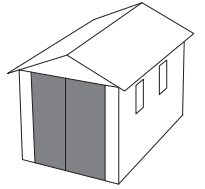

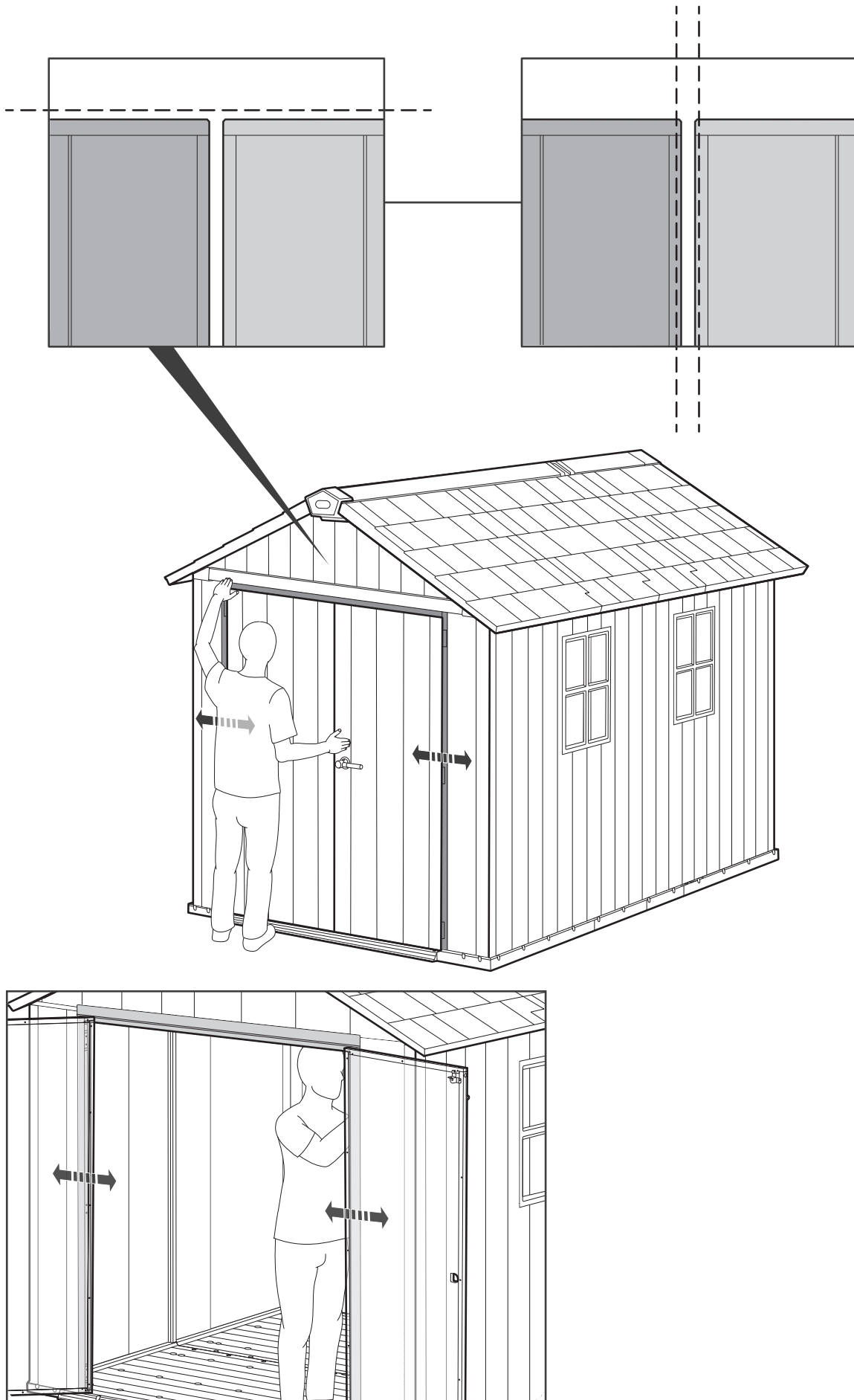

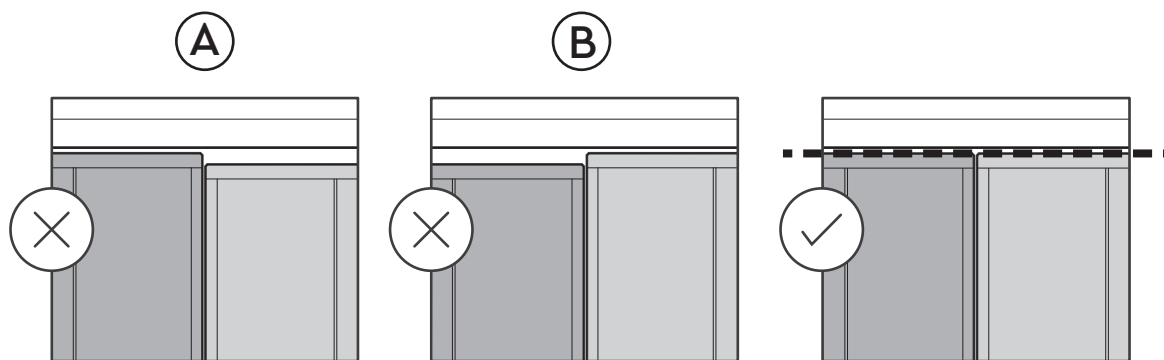

**If you find that the shed is not level, use shims on either side of the shed or door | Si vous trouvez que votre abri n'est pas de niveau, mettez des cales sur chaque côté ou au niveau de la porte | Si usted encuentra que el cobertizo no está nivelado, utilice cuñas en ambos lados del cobertizo o en la puerta | Nel caso in cui la casetta non dovesse essere in posizione orizzontale, usare degli spessori nella zona interessata**

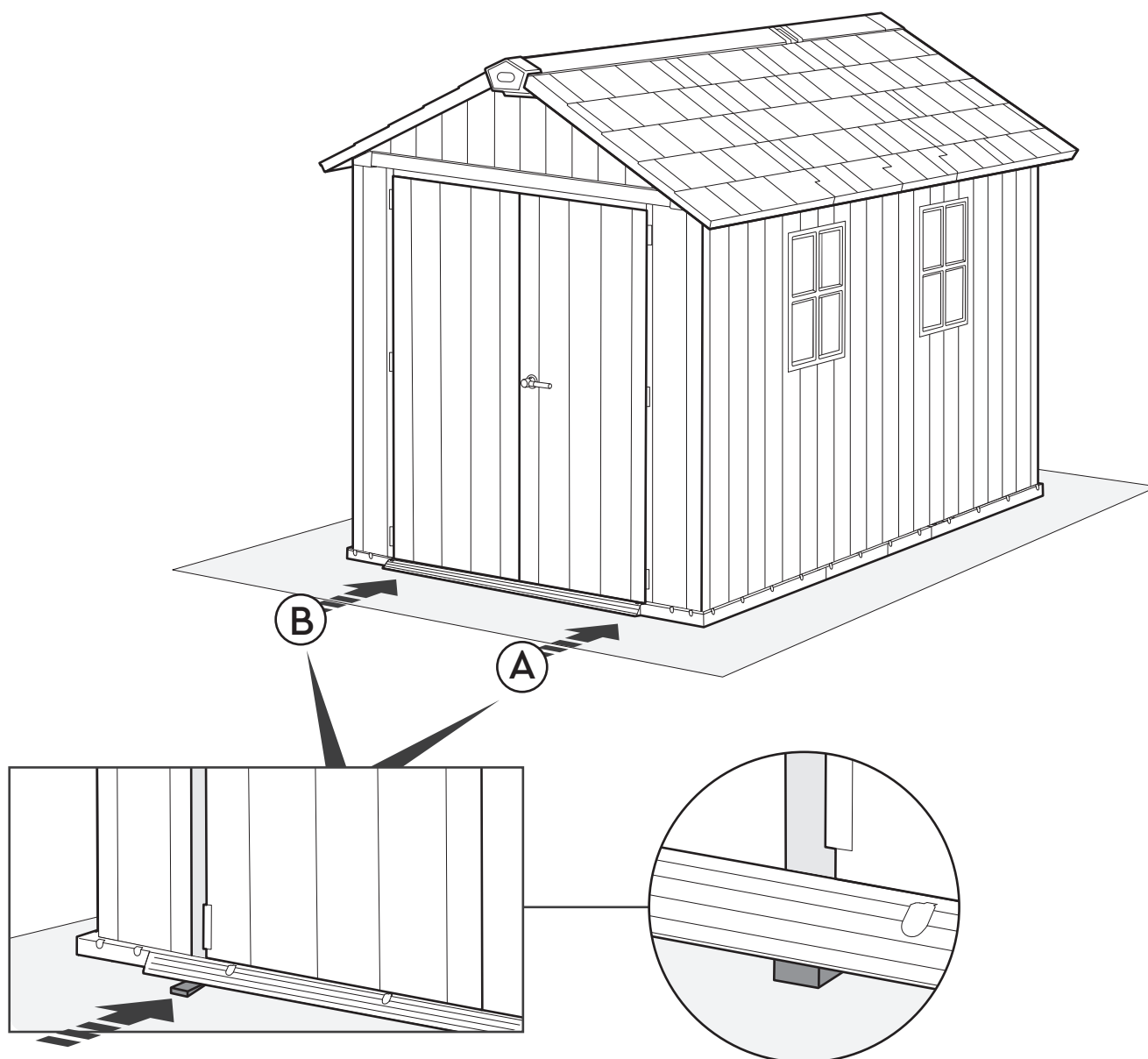



Inside | Intérieur | Interior | Innenseite  
Binnenkant | Interno | Interior

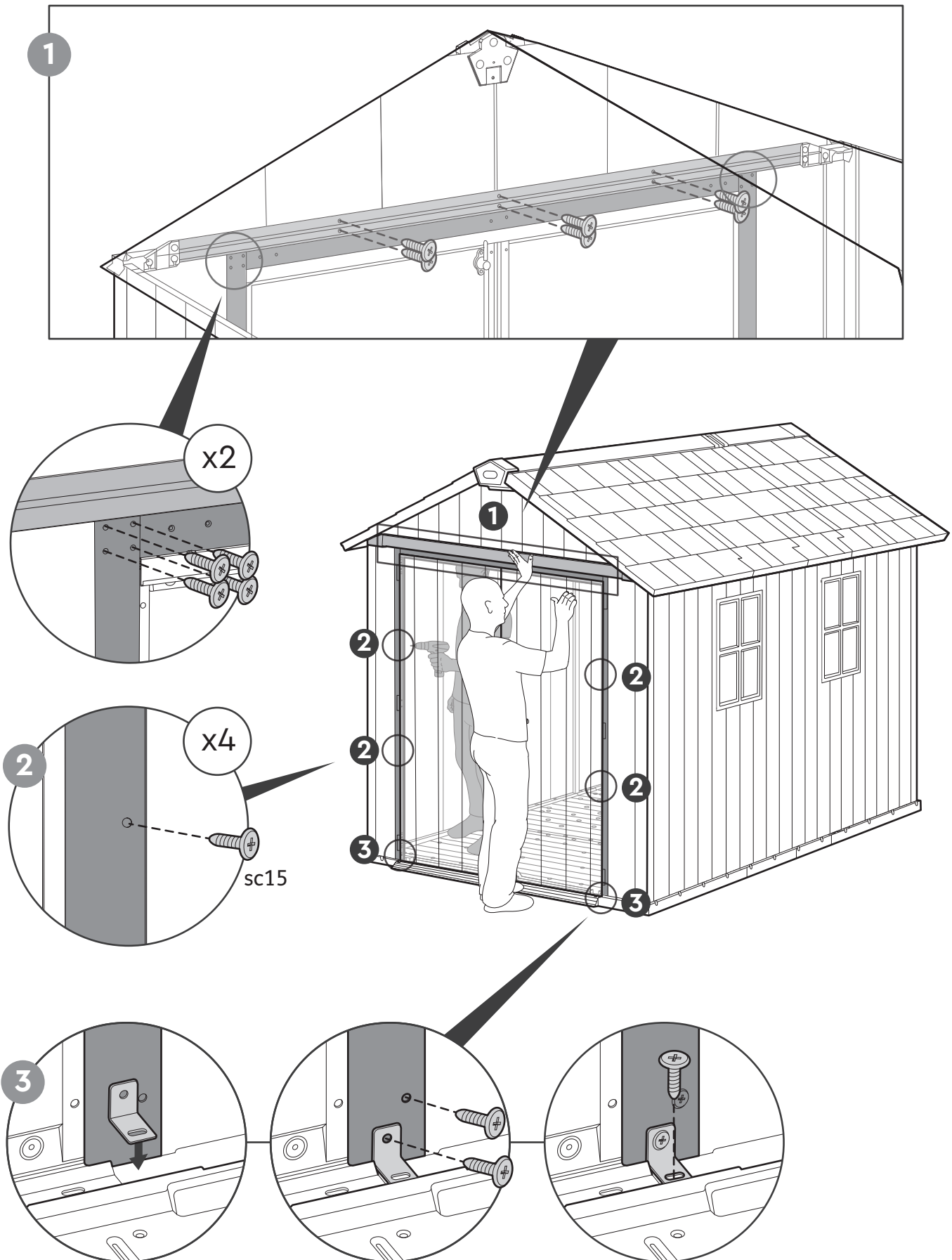

**STRONGLY RECOMMENDED | FORTEMENT RECOMMANDÉ | MUY RECOMENDADO | DRINGEND EMPFOHLEN | STERK AANBEVOLEN | SI RACCOMANDA CALDAMENTE | FORTEMENTE RECOMENDADO**

### SECURING THE SHED TO A FOUNDATION

Affix the shed to the foundation by drilling holes in the shed floor at the pre-marked locations and screwing it into the foundation using appropriate screws (screws not included).

### FIXER L'ABRI SUR UNE FONDATION

Fixez l'abri à la fondation en perçant des trous dans le sol aux endroits pré-marqués et en insérant des vis adéquates dans la fondation (vis non fournies).

### ASEGURAR EL COBERTIZO A UN CIMIENTO

Fije el cobertizo a los cimientos perforando agujeros en el suelo del cobertizo en los lugares previamente marcados y atornillelo a los cimientos utilizando los tornillos adecuados (los tornillos no están incluidos).

### ABSICHERN DES SCHUPPENS AN EIN FUNDAMENT

Bringen Sie den Schuppen auf dem Fundament an, indem Sie an den Markierungen Löcher in den Schuppenboden bohren und diesen mit passenden Schrauben auf dem Fundament festschrauben (Schrauben nicht enthalten).

### HET SCHUURTJE OP HET FUNDAMENT VASTZETTEN

Bevestig het schuurtje aan de fundering door op de aangegeven plaatsen gaten te boren in de vloer van het schuurtje en het schuurtje aan de fundering te schroeven met behulp van passende schroeven (schroeven niet inbegrepen).

### ASSICURARE LA CASSETTA ALLE FONDAMENTA

Ancorare la cassetta alle fondamenta forando il pavimento nelle posizioni indicate e applicando apposite viti (viti non incluse).

### FIXAR O ABRIGO NUMA FUNDAÇÃO

Afixe o abrigo à base abrindo buracos no chão nos locais previamente assinalados e aparafusando-o à mesma utilizando parafusos adequados (os parafusos não estão incluídos).

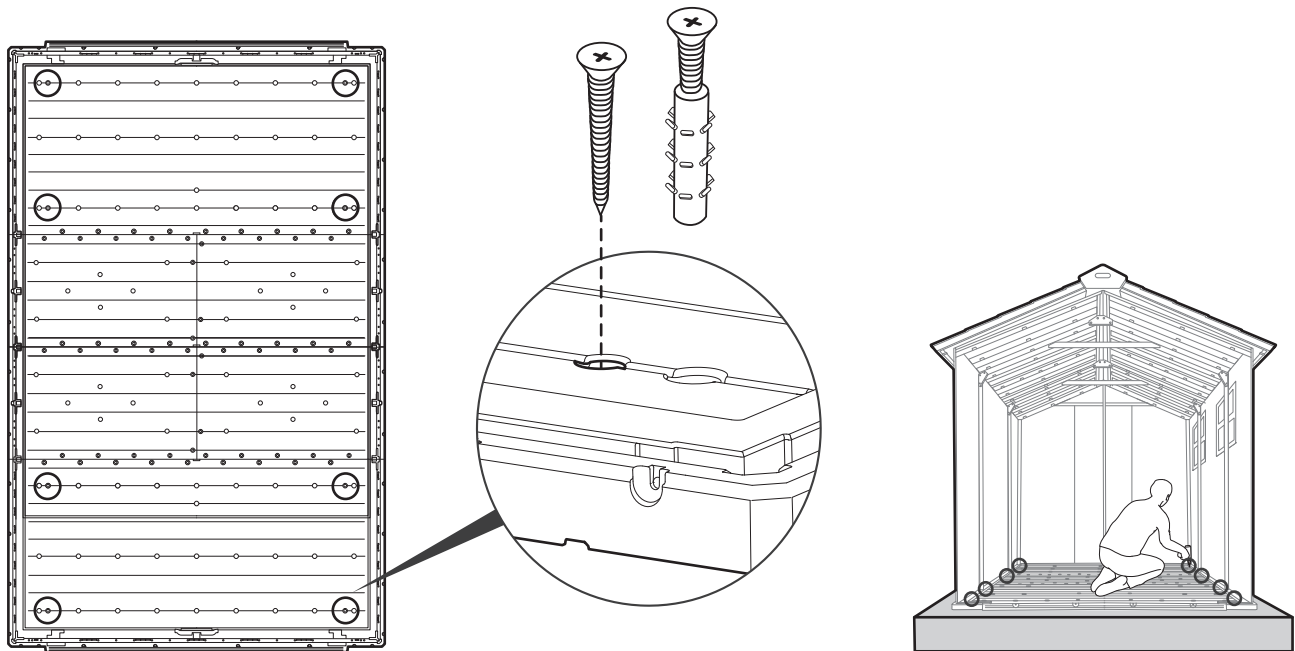

OPTION | OPTION | OPCIÓN | OPTION | OPTIE | OPZIONE | OPÇÃO

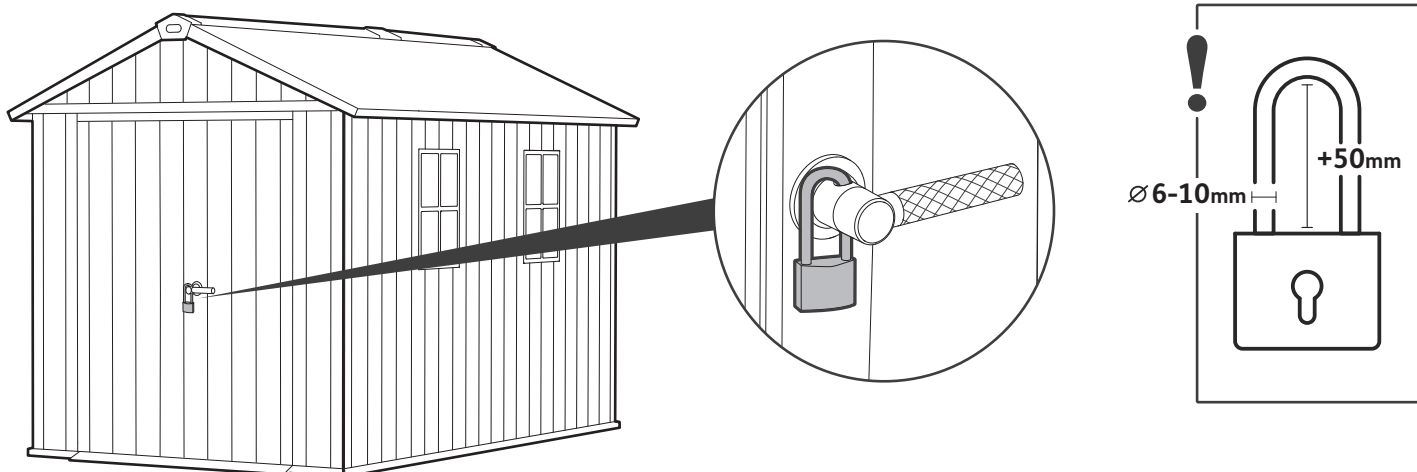

IF THERE ARE MISSING OR BROKEN PARTS, PLEASE DO NOT RETURN THE PRODUCT TO THE STORE.  
PLEASE ACCESS OUR WEBSITE WWW.KETER.COM, OR CONTACT CUSTOMER SERVICE IN YOUR COUNTRY/REGION:

S'IL Y A DES PIÈCES MANQUANTES OU CASSÉES, NE RETOURNEZ PAS LE PRODUIT AU MAGASIN.  
VEUILLEZ ACCÉDER À NOTRE SITE WEB WWW.KETER.COM OU CONTACTER LE SERVICE CLIENT DE VOTRE PAYS/RÉGION:

SI HUBIERA ALGUNA PARTE FALTANTE O DAÑADA, NO DEVUELVA EL PRODUCTO A LA TIENDA.  
ACCEDA A NUESTRA WEB WWW.KETER.COM O CONTACTO CON EL SERVICIO DE ATENCIÓN AL CLIENTE DE SU PAIS/REGIÓN:

BITTE BRINGEN SIE IHR PRODUKT NICHT GLEICH ZUM LADEN ZURÜCK, FALLS TEILE FEHLEN ODER DEFEKT SIND.  
BITTE LOGGEN SIE IN UNSERE WEBSITE EIN ODER WENDEN SIE SICH AN UNSEREN KUNDENSERVICE:

IN GEVAL VAN ONTBREKENDE OF BESCHADIGDE ONDERDELEN KUNT U GEBRUIK MAKEN VAN DE KETER ONDERDELENSERVICE  
GA NAAR ONZE WEBSITE WWW.KETER.COM OF NEEM CONTACT OP MET DE KLANTENSERVICE VIA ONDERSTAANDE  
CONTACTGEGEVENS:

IN CASO DI PARTI MANCANTI O ROTTE, PREGHIAMO DI NO RESTITUIRE IL PRODOTTO AL NEGOZIO.  
CHIEDIAMO CORTESEMENTE DI ACCEDERE AL NOSTRO SITO WEB WWW.KETER.COM O, CONTATTARE IL SERVIZIO CLIENTI DEL  
VOSTRO PAESE:

SE EXISTEREM PEÇAS DANIFICADAS OU PARTIDAS POR FAVOR NÃO EFECTUAR DEVOUÇÃO À LOJA.  
ACEDA AO NOSSO SITE WWW.KETER.COM OU AO NOSSO SERVIÇO DE PÓS VENDA:

**US/Canada:** (EN/FR)  
Tel: +1-888-374-4262  
keter.com/en-us/contact-us.html  
Email: NACS@keter.com

**UK:** (EN)  
Tel: +44-121-506-0008  
Email: CSUK@keter.com  
Keter UK Ltd  
16 Great Queen Street, Covent  
Garden, London, WC2B 5AH  
Mon - Fri | 8am - 4pm

**Israel:**  
Tel: 1-700-70-6015

**Switzerland:**  
Tel: +41-62-767-00-50  
Email: info@neogard.ch

**France:**  
Votre produit ayant été acheté dans  
une enseigne, qu'elle soit physique ou  
sur internet, c'est auprès de cette  
enseigne que vous devez faire votre  
demande SAV.

**Australia:**  
Tel: 03 9544 6999  
Email: keteraus@keter.com  
28 Buckland St,  
Clayton, Victoria 3168  
Mon - Fri | 9am - 5pm

**Iberia:**  
Email: spvketer@carcaba.com

**South Africa:**  
Email: info@keter.co.za

**Spain:** (SP)  
Tel: +34-949-277-421  
Email: spvketer@carcaba.com  
Avenida Conde de Romanones 6-b.  
Polg. Ind. Miralcampo,  
19200 Azuqueca de Henares -  
Guadalajara, Spain  
Mon - Fri | 9am - 7pm

**Italy:**  
Tel: +39 0422 745900  
Email: Servizio.clienti@keter.com

**고객센터:**  
Tel: 031-767-2492  
Email: info@keter.co.kr  
월 - 금 | 9:00am - 05:30pm

**Poland:**  
Tel: +48 59 84 19 892  
Email: Service.poland@keter.com

**Hungary:**  
Tel: +36 52 565 920  
Email: Service.hungary@keter.com

**Nordics:**  
Tel: +48 59 84 19 892  
Email: Service.nordic@keter.com

**Germany/Austria:**  
Tel: +49 (3) 222-10-96-42-1  
Email: service@keter-ersatzteile.de

**NL/BE/LUX:**  
Email: Klantenservice@keter.com

WWW.KETER.COM

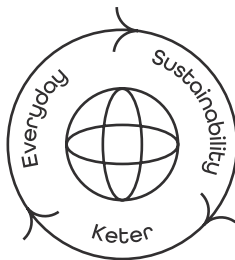

**KETER**

Le développement durable au  
quotidien | Sostenibilidad día a día



Designed to Last | Conçu pour durer | Diseñado  
para durar | Auf Langlebigkeit ausgelegt |  
Duurzaam ontworpen | Progettato per durare |  
Projetado para durar



Recyclability & Recycling | Recyclabilité et  
Recyclage | Reciclabilidad y reciclable | recyclefähig  
& recycelt | Recyclebaarheid & recycling |  
Riciclabilità e Riciclo | Reciclabilidade e Reciclagem



Community | Communauté |  
Comunidad | Community |  
Community | Comunità | Comunidade



Responsible Manufacturing | Fabrication responsable |  
Producción responsable | Verantwortungsbewusste  
Herstellung | Verantwoorde productie |  
Produzione responsabile | Fabricação responsável

Made in Israel by | Fabriqué en Israël par | Hecho en Israel por | Hergestellt in Israel von | Gemaakt in Israël door |  
Realizzato in Israele da | Fabricado em Israel por Keter Home and Garden Products Ltd., 1 Sapir St. Industrial Area,  
Herzliya 4685205, Israel



<https://quefairedemesdechets.fr>

**KETER**