

KETER

Create amazing spaces™

MANUAL

DELUXE SIDE TABLE

USER MANUAL | MODE D'EMPLOI | MANUAL DEL USUARIO | MONTAGEANLEITUNG |
MONTAGEHANDLEIDING | MANUALE PER L'UTENTE | MANUAL DO UTILIZADOR

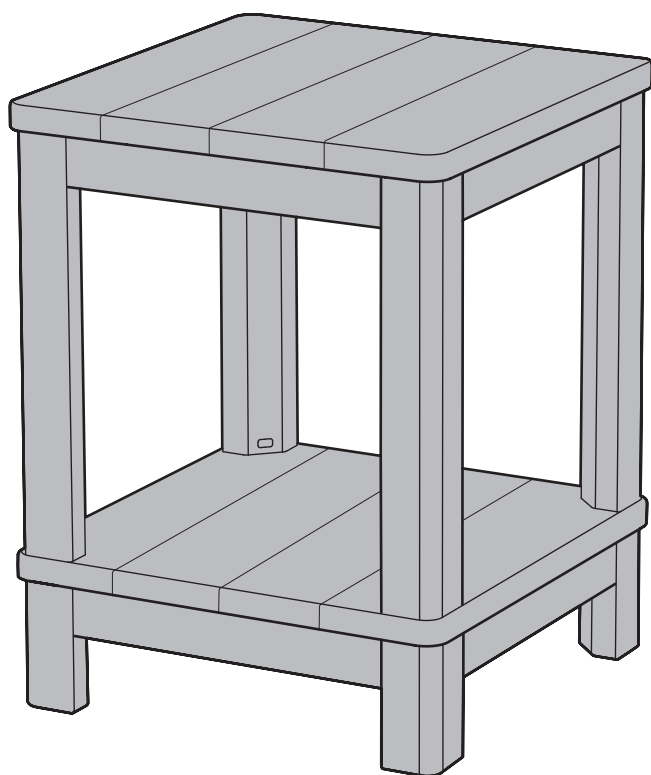

WWW.KETER.COM

US, Canada

Tel: +1877-638-7056, NACS@keter.com
Mon - Fri | 8am - 6pm ET / Lundi-Vendredi 8h -18h
Sat - Sun | 9am - 6pm ET / Samedi-Dimanche 9h-18h

UK

Tel: +44-121-506-0008, CSUK@keter.com
Mon - Fri | 8:30am - 5pm

For other European countries see the last page
Pour les autres pays d'Europe, voir la dernière page
Para otros países europeos vea la última página

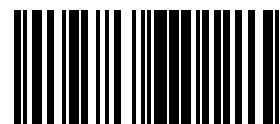

5011759



ATTENTION | IMPORTANT | ATENCIÓN | ACHTUNG | LET OP | ATTENZIONE | ATENÇÃO

Read carefully. | Instructions to be kept for further reference. | Position in a stable way on a flat ground. | Spare parts not available beyond guarantee. | For domestic and contract use. | For outdoor use. | Care Instructions. Use only neutral soap and a wet cloth to clean.

Lire attentivement. | A conserver pour une consultation ultérieure, à lire attentivement. | Positionner de manière stable sur un sol plan. | Pièces détachées non disponibles hors garantie. | À usage domestique et collectif. | Pour un usage extérieur. | Notice d'entretien. N'utilisez que du savon neutre et un chiffon humide pour nettoyer.

Léase con atención. | Guardar las instrucciones para futura referencia. | Colocar en una posición estable sobre terreno llano. | Piezas de repuesto no disponibles finalizada la garantía. | Para uso doméstico y profesional. | Para uso en exteriores. | Instrucciones de Mantenimiento. Lavar con un trapo humedecido y jabón neutro.

Sorgfältig lesen. | Anleitung soll als zukünftige referenz aufbewahrt werden. | Stabil auf ebenem Boden aufstellen. | Ersatzteile nach auslaufen der garantie nicht erhältlich. | Für private und gewerbliche Nutzung. | Für die Verwendung im Freien. | Pflegehinweis. Zur Reinigung bitte nur PH-neutrale Seife und ein feuchtes Tuch verwenden.



Lees zorgvuldig. | Instructies moeten voor toekomstige raadpleging worden bewaard. | Plaats op stabiele wijze op een vlakke ondergrond. | Reserveonderdelen zijn niet verkrijgbaar na de garantieperiode. | Voor huishoudelijk en contractgebruik. | Voor gebruik buiten. | Onderhoudsinstructies. Gebruik alleen neutrale zeep en een vochtige doek om te reinigen.

Leggere attentamente. | Le istruzioni devono essere conservate con cura per riferimenti futuri. | Posizionare in maniera stabile o su un terreno piano. | Pezzi di ricambio non disponibili superato il periodo di garanzia. | Per uso domestico e in locali pubblici. | Per uso all'esterno. | Istruzioni per la cura del prodotto. Utilizzare un sapone neutro e pulire con un panno umido.

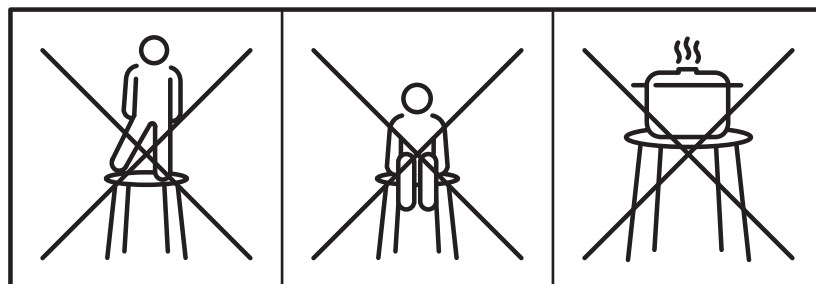
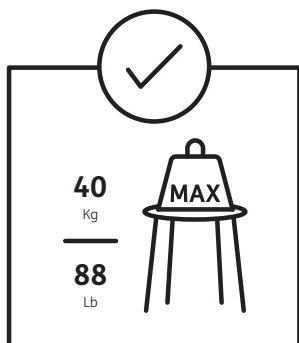
Leia com atenção. | As instruções devem ser guardadas para referência futura. | Posicionar numa forma estável num piso plano. | As peças sobressalentes não estão disponíveis além da garantia. | Para uso doméstico e contractual. | Para uso ao ar livre. | Instruções de uso. Utilize um pano húmido e um sabão neutro.

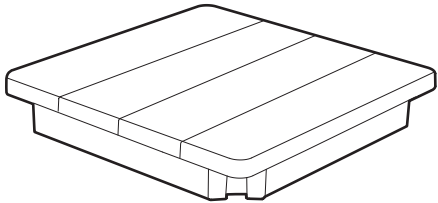
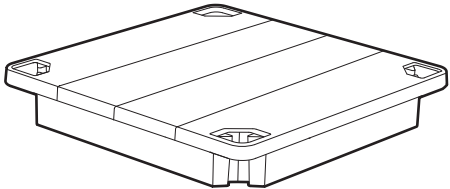

ASSEMBLY PARTS | PIÈCES À ASSEMBLER | PIEZAS DE ENSAMBLE | MONTAGETEILE | PARTI DA MONTARE | ONDERDELEN | PEÇAS DE MONTAGEM |

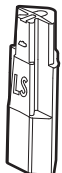
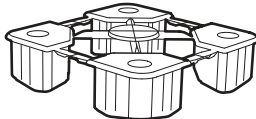
 <p>T (X1)</p>	 <p>B (x1)</p>	
 <p>L (x4)</p>	 <p>LS (x4)</p>	 <p>P (x4)</p>

1

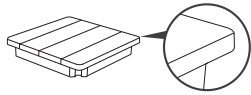

T (x1)



L (x4)

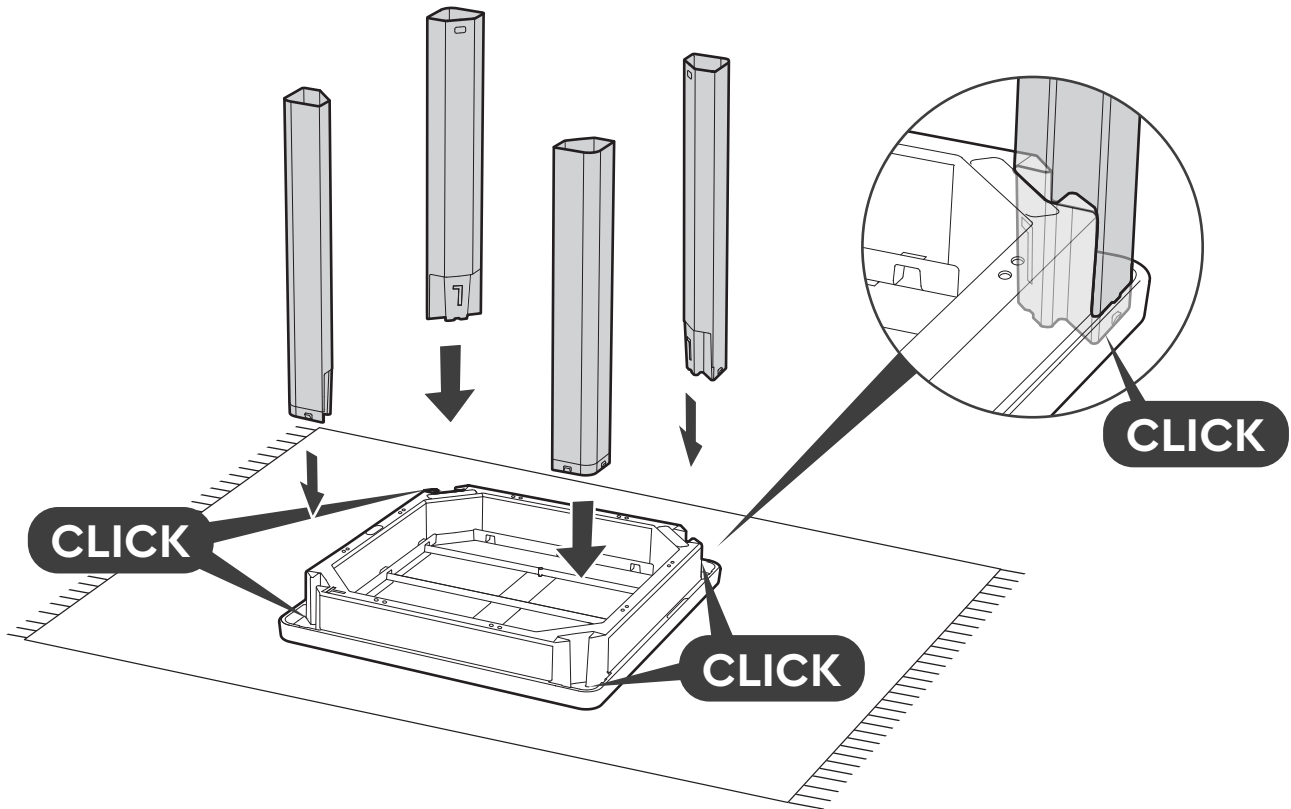

2



T + L

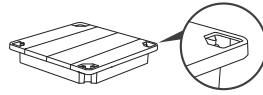

B (x1)



LS (x4)

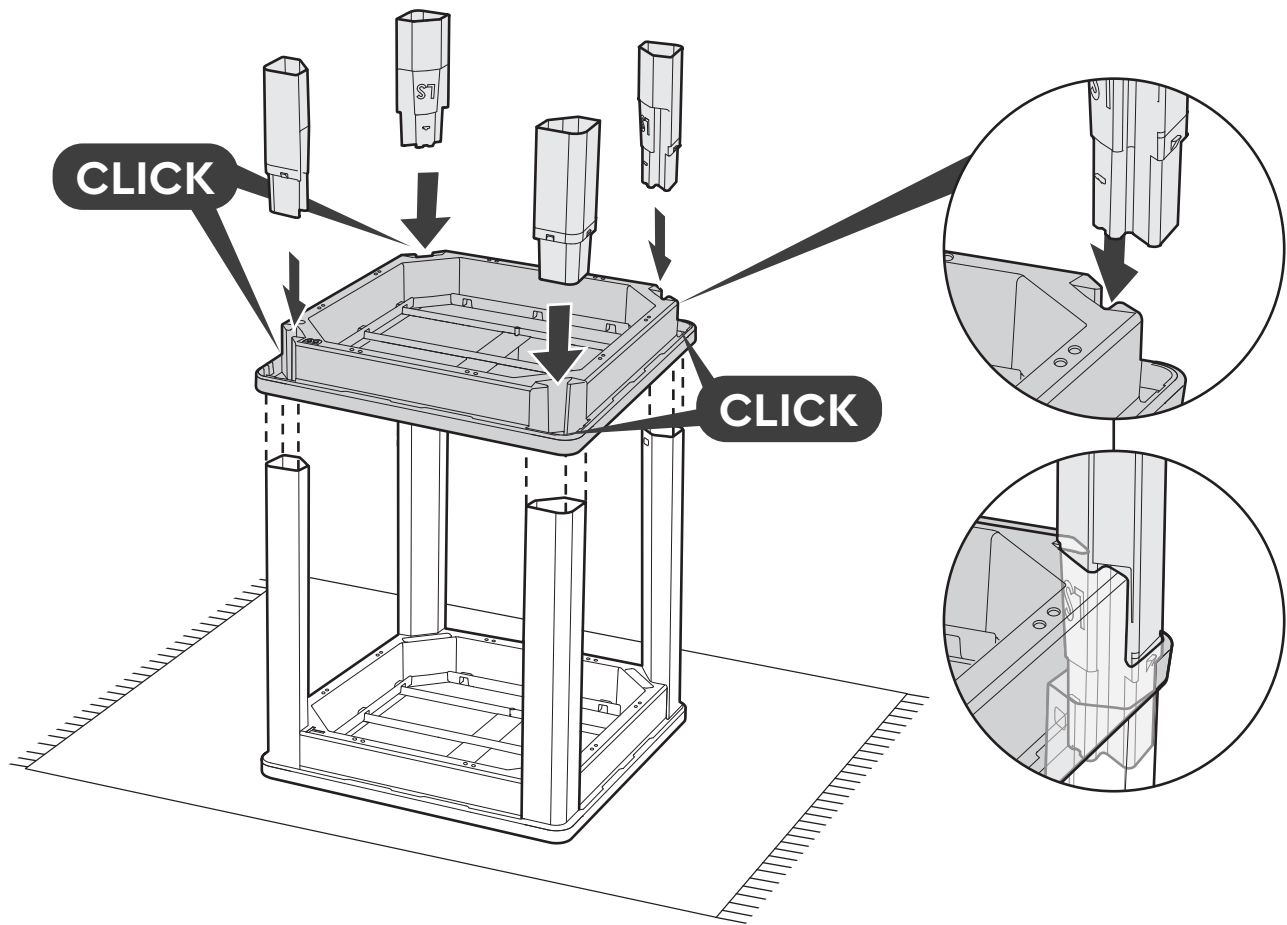
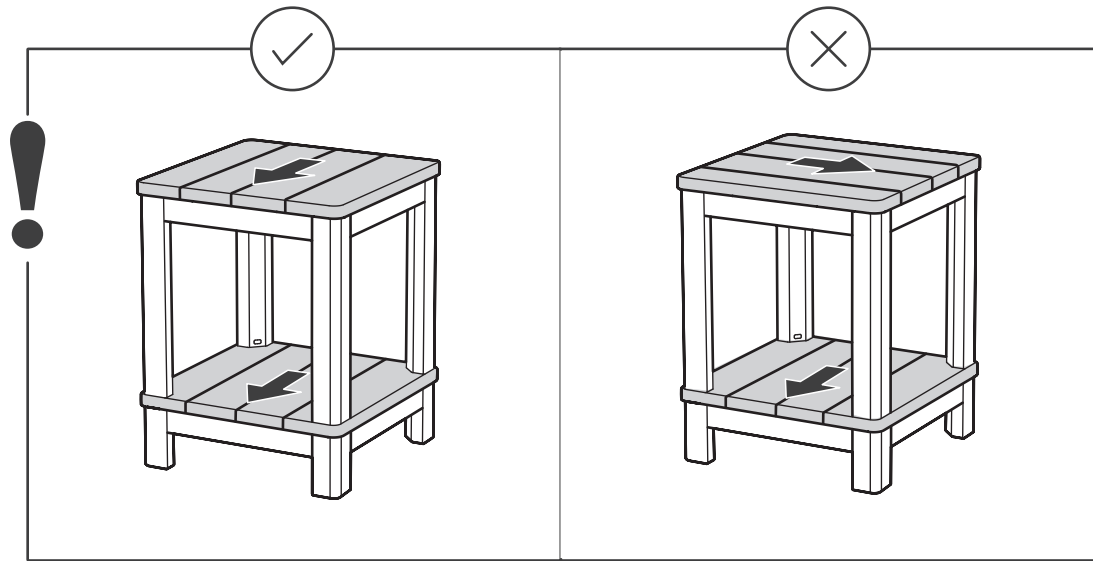

3

  P (x4)

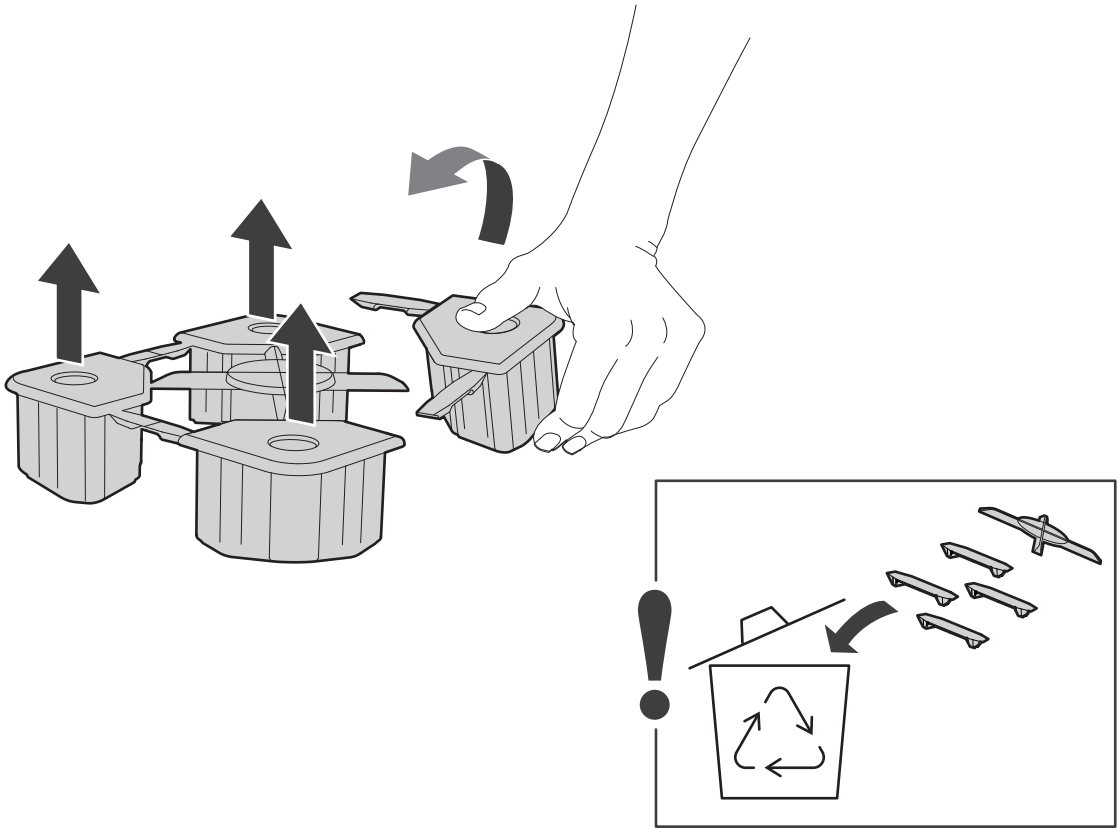

4

 P (x4)

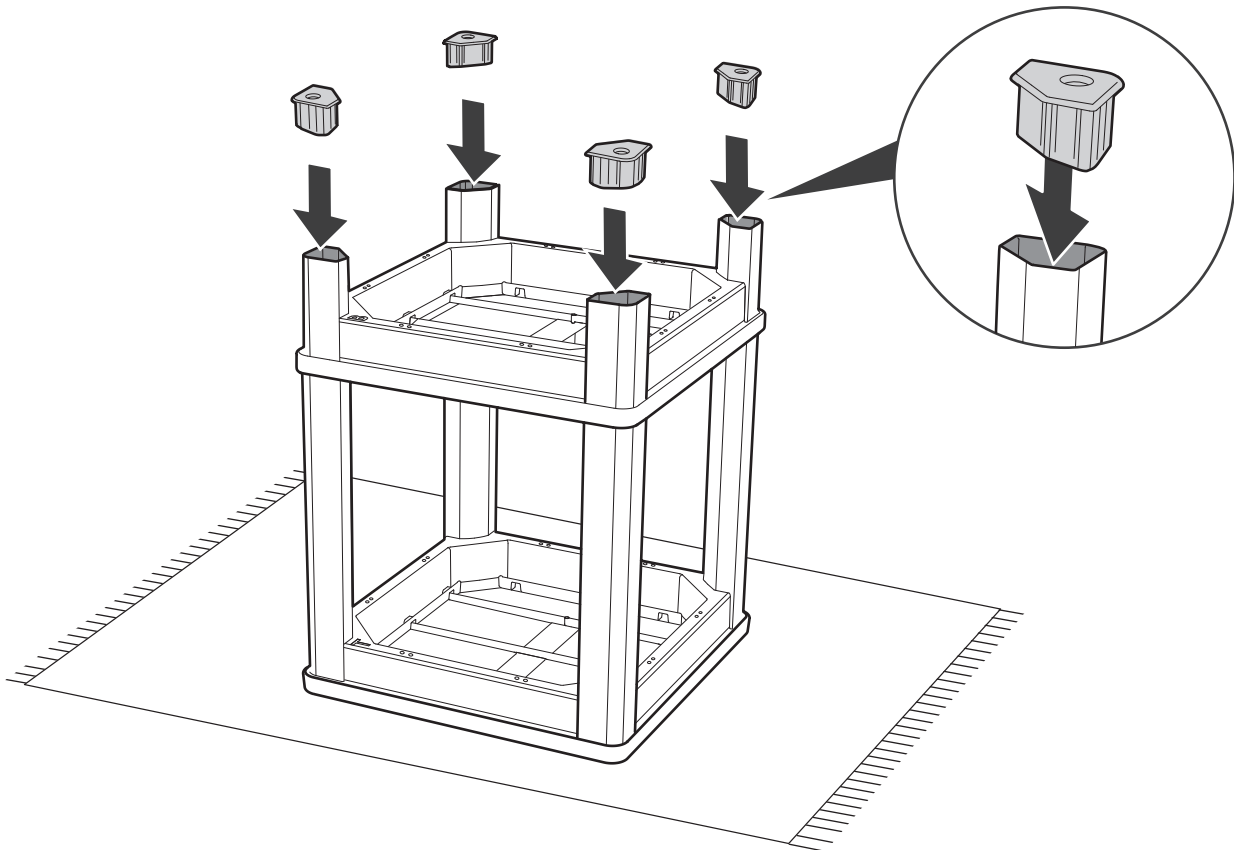

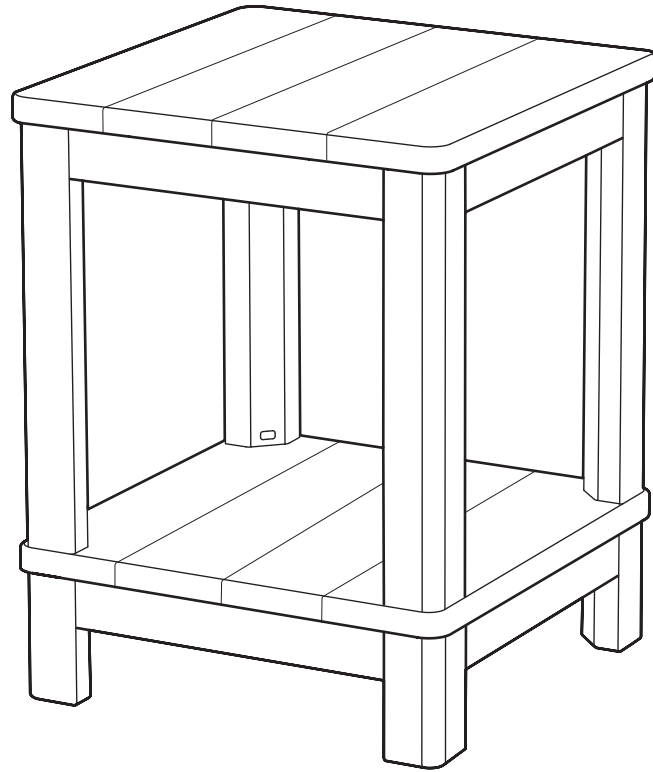



**IF THERE ARE MISSING OR BROKEN PARTS, PLEASE DO NOT RETURN THE PRODUCT TO THE STORE.
Please log onto our website, or contact Customer Service at:**

S'IL Y A DES PIÈCES MANQUANTES OU CASSÉES, NE RETOURNEZ PAS LE PRODUIT AU MAGASIN.
Veuillez visiter notre site Internet, ou contacter notre Service Clientèle:

SI HUBIERA ALGUNA PARTE FALTANTE O DAÑADA, NO DEVUELVA EL PRODUCTO A LA TIENDA.
Inicie sesión en nuestro sitio en Internet o contáctese con nuestro servicio de atención al cliente:

BITTE BRINGEN SIE IHR PRODUKT NICHT GLEICH ZUM LADEN ZURÜCK, FALLS TEILE FEHLEN ODER DEFEKT SIND.
Bitte loggen Sie in unsere Website ein oder wenden Sie sich an unseren Kundenservice:

IN GEVAL VAN ONTBREKENDE OF GEBROKEN ONDERDELEN NIET HET PRODUCT NAAR DE WINKEL RETOURNEREN.
Ga naar onze website of neem contact op met de Klantenservice:

IN CASO DI PARTI MANCANTI O DANNEGGIATE, EVITARE DI RESTITUIRE IL PRODOTTO AL NEGOZIO.
Accedere al nostro sito o contattare il Servizio Clienti:

SE HOVER PEÇAS EM FALTA OU PARTIDAS, NÃO DEVOLVA O PRODUTO À LOJA.
Entre na nossa página de Internet ou contacte o Serviço de Clientes:

WWW.KETER.COM

US, Canada: (EN / FR)
Tel: +1877-638-7056
email: NACS@keter.com
Mon - Fri | 8am - 6pm ET
Lundi-Vendredi 8h -18h
Sat - Sun | 9am - 6pm ET
Samedi-Dimanche 9h-18h

UK: (EN)
Tel: +44-121-506-0008
email: CSUK@keter.com
Keter UK Ltd
Cardrew Way, Redruth, Cornwall
TR15 1ST
Mon - Fri | 8:30am - 5pm

Switzerland:
Tel: +41-62-767-00-50
email: info@neogard.ch

France:
Votre produit ayant été acheté dans une enseigne, qu'elle soit physique ou sur internet, c'est auprès de cette enseigne que vous devez faire votre demande SAV.

Australia:
Tel: 03 9544 6999
Email: keteraus@keter.com
28 Buckland St,
Clayton, Victoria 3168
Mon - Fri | 9am - 5pm

Spain: (SP)
Tel: +34-949-277-421
Avenida Conde de Romanones 6-b.
Polg. Ind. Miralcampo,
19200 Azuqueca de Henares -
Guadalajara, Spain
Mon - Fri | 9am - 7pm

Germany / Austria
Tel: +49 (0) 481-21-22-46-3
email: service@keter-ersatzteile.de

Italy
email: info.it@keter.com

Iberia
Tel: +949-27-74-21
email: spvketer@carcaba.com

Israel
Tel: 1-700-70-6015
email: Ketercs@keter.com

South Africa
Tel: 0861-866-766
email: info@keter.co.za
Website: za.Keter.com

Poland
Tel: +48 59 84 19 892
email: Service.poland@keter.com

Hungary
Tel: +36 52 565 920
email: Service.hungary@keter.com

Scandinavia
Tel: +48 59 84 19 892
email: Service.nordic@keter.com

고객센터
Tel: 031-767-2492
E-mail: info@keter.co.kr
월 - 금 | 9:00am - 05:30pm

Other European Countries
Tel: +31-1612-28300
email: service@keter.com
Mon - Fri | 8:30am - 5pm

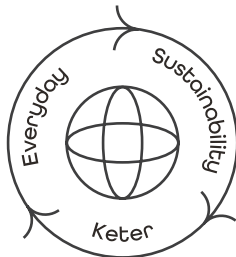

KETER

Le développement durable au quotidien | Sostenibilidad día a día



Designed to Last | Conçu pour durer | Diseñado para durar | Auf Langlebigkeit ausgelegt | Duurzaam ontworpen | Progettato per durare | Projetado para durar



Recyclability & Recycling | Recyclabilité et Recyclage | Reciclabilidad y reciclable | recycelfähig & recycelt | Recyclebaarheid & recycling | Riciclabilità e Riciclo | Reciclabilidade e Reciclagem



Community | Communauté | Comunidad | Community | Community | Comunità | Comunidade



Responsible Manufacturing | Fabrication responsable | Producción responsable | Verantwortungsbewusste Herstellung | Verantwoorde productie | Produzione responsabile | Fabricação responsável

Made in Israel by | Fabriqué en Israël par | Fabricado en Israel por | Hergestellt in Israel von | Gemaakt in Israël door | Realizzato in Israele da | Fabricado em Israel por
Keter Plastic Ltd., 1 Sapir St. Industrial Area, Herzliya 4685205, Israel



5011759